

ABSTRACT & PROGRAM

ICEBA2023

The 4th International Conference on
Engineering Physics, MEMS-Biosensors
and Applications

Host by

*VNUHCM-University of Science (Vietnam)
& Tohoku University (Japan)*



VNUHCMUS-University of Science, Vietnam

December 8-9, 2023

Organization



HCMUS
Viet Nam National University
Ho Chi Minh City



東北大学
TOHOKU
UNIVERSITY

Technical Supports



INSTITUTE OF KOREAN
ELECTRICAL AND
ELECTRONICS ENGINEERS



The 4th International Conference on Engineering Physics, MEMS-Biosensors and Applications (ICEBA2023)

VNUHCM-University of Science, December 8-9, 2023

Venue: 227 Nguyen Van Cu Street, District 5, Ho Chi Minh City, Vietnam

ABSTRACT & PROGRAM

ICEBA2023

**The 4th International Conference on
Engineering Physics, MEMS-Biosensors and
Applications**

VNUHCM-University of Science, Ho Chi Minh city, Vietnam

December 8-9, 2023

The 4th International Conference on Engineering Physics, MEMS-Biosensors and Applications (ICEBA2023)

VNUHCM-University of Science, December 8-9, 2023

Venue: 227 Nguyen Van Cu Street, District 5, Ho Chi Minh City, Vietnam

Co-organizers

University of Science, Vietnam National University- Hochiminh city, Vietnam
Tohoku University, Sendai, Japan

General Chairs

Takahito Ono, *Graduate School of Engineering, Tohoku University-Japan*
Nguyen Van Hieu, *Dept. of Science and Technology, Vietnam National University HoChiMinh City*

Scientific Committee

Takahito Ono, *Tohoku University-Japan*
Chau Van Tao, *VNUHCM-University of Science-Vietnam*
Masaya Toda, *Tohoku University- Japan*
Do Hong Tuan, *VNUHCM-UT & IEEE Vietnam Section*
Nguyen Van Hieu, *Vietnam National University HCMC*
Le Vu Tuan Hung, *VNUHCM-University of Science-Vietnam*
Phan Bach Thang, *VNUHCM-INOMAR-Vietnam*
Kyeong-Sik Min, *Kookmin University & IKEEE-Korea*
Ching Tak Shing Congo, *National Chung Hsing University-Taiwan (R.O.C)*
Jen-Inn Chyi, *National Central University- Taiwan (R.O.C)*
Kun-Yu Lai, *National Central University-Taiwan (R.O.C)*
Nguyen Hoang Nam, *VNU Ha Noi-University of Science-Vietnam*

Program Committee

Huynh Van Tuan, *VNUHCM-University of Science-Vietnam, Chair*
Nguyen Van Toan, *Tohoku University-Japan, Co-chair*
Tran Thien Thanh, *VNUHCM-University of Science-Vietnam*
Hoang Trang, *VNUHCM-University of Technology- Vietnam*
Huynh Chan Khon, *VNUHCM-International University-Vietnam*
Vu The Dang, *Osaka Metropolitan University- Japan*
Dau Van, *Griffith University-Australia*
Nguyen Chi Nhan, *VNUHCM-University of Science-Vietnam*
Nguyen Van Men, *VNUHCM- An Giang University-Vietnam*
Truong Thi Kim Tuoi, *Tohoku University-Japan*
Nguyen Quang Khoi, *VNUHCM-US Vietnam*
Nguyen Chi Linh, *VNUHCM-US Vietnam*

The 4th International Conference on Engineering Physics, MEMS-Biosensors and Applications (ICEBA2023)

VNUHCM-University of Science, December 8-9, 2023

Venue: 227 Nguyen Van Cu Street, District 5, Ho Chi Minh City, Vietnam

Publication Committee

Takahito Ono, *Tohoku University, Japan*

Nguyen Van Hieu, *Vietnam National University HCMC, Vietnam*

Huynh Van Tuan, *VNUHCM-University of Science, Vietnam*

Local Organizing Committee

Nguyen Chi Nhan, *VNUHCM-US Vietnam, Chair*

Vo Hong Hai, *VNUHCM-US Vietnam, Co-chair*

Ho Thanh Huy, *VNUHCM-US Vietnam*

Huynh Thanh Nhan, *VNUHCM-US Vietnam*

Do Duc Cuong, *VNUHCM-US Vietnam*

Trinh Thi Ly, *VNUHCM-US Vietnam*

Nguyen Hoang Quan, *VNUHCM-US Vietnam*

Phan Thien Luan, *NCHU-Taiwan (R.O.C)*

Secretariats

Nguyen Phuoc Hoang Khang, *VNUHCM-US Vietnam*

Hua Thi Hoang Yen, *VNUHCM-US Vietnam*

Nguyen Vuong Thuy Ngan, *VNUHCM-US Vietnam*

Contact for 4ICEBA2023

Address: 227 Nguyen Van Cu Street, District 5, Ho Chi Minh city, Vietnam.

Email: 4iceba2023@gmail.com

Contact: Office of Faculty of Physics and Engineering Physics, A Building

Website: <https://phys.hcmus.edu.vn/ICEBA2023/#/>

The 4th International Conference on Engineering Physics, MEMS-Biosensors and Applications (ICEBA2023)

VNUHCM-University of Science, December 8-9, 2023

Venue: 227 Nguyen Van Cu Street, District 5, Ho Chi Minh City, Vietnam

Message from the President
VNUHCM-University of Science
Prof. Tran Le Quan

Dear Professors, Scientists, colleagues and students,

On behalf of the University of Science, I am very honored to welcome all of you to the 4th International Conference held at the University of Science, Vietnam National University, Ho Chi Minh City. Thanks for your cooperation in hosting and co-hosting this conference with Tohoku University, Japan.

About the 4th ICEBA2023, we also agree that this international conference will enhance international cooperation with activities with our partnership in Vietnam and worldwide in the fields of Engineering Physics, MEMS biosensors, and Applications.

It is the 4th time for this international conference that cooperation with Tohoku University. We would like to thank the technical support from IEEE Vietnam Section, Institute Electrical Engineer of Japan (IEEJ, Japan), Institute of Korean Electrical & Electronic Engineers (IKEEE, Korea) and Hochiminh Semiconducting Industrial Association (HSIA).

From the organizer of ICEBA2023, we know there are some new partnership for the 5th ICEBA2025 and the 6th ICEBA2026 to enhance the international co-publication in Scopus/ISI Journal and increasing the number of participants of ICEBA International Conference. The president of VNUHCM-US will strongly support for these international cooperation.

Thanks for your help and useful cooperation.

From the report of Program chair, I know there are total 77 papers in 4th ICEBA2023 as invited talk session and both oral presentation session and poster presentation session. Some of them will be review and publish on the Scopus/ISI international Journal of IEEJ.

We also thank Prof. Takhito Ono (from Tohoku University, Japan) and Prof. Nguyen Van Hieu who are General chair and General Co-chair of the 1st, 2nd, 3rd and 4th ICEBA Conference.

Moreover, I am appreciated the careful preparation over the past many months for ICEBA2023 to open today from the program committee, the local organizing committee, the secretariats, the dean/vice and other professors, lecturers, academic staff of Faculty of Physics – Engineering Physics.

Again, I would like to thank all professors, researchers, and colleagues for contributing their invited talks, oral talks, and poster presentations and the support as chair/co-chair of 6 sessions. We hope to see you again 5ICEBA2024 international conference in November 2024 at University of Science.

With our best regards,

Tran Le Quan

The 4th International Conference on Engineering Physics, MEMS-Biosensors and Applications (ICEBA2023)

VNUHCM-University of Science, December 8-9, 2023

Venue: 227 Nguyen Van Cu Street, District 5, Ho Chi Minh City, Vietnam

Welcome Remark from Prof. Takahito Ono
Graduate School of Mechanical Engineering
General Chair of 4th ICEBA 2023

Dear Professors, Colleagues and Students,

I am Tahito Ono, professor in Tohoku University, Japan. Today, I am very happy to visit Vietnam again for the 4th International Conference on Engineering Physics, MEMS-Biosensors and Applications. ICEBA2023 is held at the University of Science, Vietnam National University, Ho Chi Minh City. I am also honored to be the General Chair and a member of International Scientific Committee. Specially, I am thank the program committee to invite my for a plenary invited talk in the Opening Ceremony of ICEBA2023.

Here, Thank for Prof. Nguyen Van Hieu who is Genneral Co-chair of the ICEBA2023 with me to arrange this Conference. Moreover, I would like to thank Prof. Huynh Thanh Tuan (Dean of FPEP) who is program Chair. And, I also thanks Dr. Nguyen Chi Nhan (Head of DPEE) for his nice local Oraginzzting Committee.

The aims of this conference to make the link and international cooperation with scientists in Engineering Physics, Computing Science, Embedded Systems, MEMS- Sensor, Nanotechnology, and IoT-AI, for research projects and educations. As you know semiconducting technologies and devices, IC chips and sensors will be very important for the development of electronics industry and automobile and machinery industries. Our Tohoku University is very strong in the fields of mecanical engineering and MEMS.

Through cooperation for this international conference ICEBA, we hope to support the University of Science in doctoral training, developing research directions on MEMS, sensors, biosensors. University of Science professors are also very strong in the fields of IoT - AI, Embedded system, computing program, so we will have research cooperation from manufacturing MEMS, sensors, biosensors and continue for applications in the field of biomedical, environmental and high-tech agriculture in next time. Moreover, we will do the exchange program for faculty member, researchers and students for research projects and co-publications.

Once again, thank for the pleasant and successful International Conference. We hope to see all of you from in Asian countries and EU, Australia in the 5thICEBA2023 and the next Conference. Thanks and best,

Takahito Ono

The 4th International Conference on Engineering Physics, MEMS-Biosensors and Applications (ICEBA2023)

VNUHCM-University of Science, December 8-9, 2023

Venue: 227 Nguyen Van Cu Street, District 5, Ho Chi Minh City, Vietnam



CALL FOR PAPERS

General Co-Chairs

Takahito Ono
Tohoku University, Japan
Nguyen Van Hieu
VNUHCM, Vietnam

Scientific Committee

Takahito Ono, Japan
Chau Van Tao, Vietnam
Masaya Toda, Japan
Do Hong Tuan, IEEE Vietnam Section
Nguyen Van Hieu, Vietnam
Le Vu Tuan Hung, Vietnam
Phan Bach Thang, Vietnam
Kyeong-Sik Min, Korea
Ching Tak Shing Congo, Taiwan
Jen-Inn Chyi, Taiwan
Nguyen Hoang Nam, Vietnam

Program Committee

Huynh Van Tuan, Vietnam (Chair)
Nguyen Van Toan, Japan (Co-chair)
Tran Thien Thanh, Vietnam
Hoang Trang, Vietnam
Kun-Yu Lai, Taiwan
Huynh Chan Khon, Vietnam
Vu The Dang, Japan
Dau Van, Australia
Nguyen Chi Nhan, Vietnam
Nguyen Van Men, Vietnam
Truong Thi Kim Tuoi, Japan
Nguyen Quang Khoi, Vietnam
Nguyen Chi Linh, Vietnam

Local Organizing Committee

Nguyen Chi Nhan, Vietnam (Chair)
Vo Hong Hai, Vietnam (Co-chair)
Ho Thanh Huy, Vietnam
Huynh Thanh Nhan, Vietnam
Do Duc Cuong, Vietnam
Trinh Thi Ly, Vietnam
Nguyen Hoang Quan, Vietnam
Phan Thien Luan, Taiwan

Secretariats

Nguyen Phuoc Hoang Khang
Hua Thi Hoang Yen
Nguyen Vuong Thuy Ngan

Deadline

- Abstract submission and registration: October 30th, 2023
- Full paper submission for presentation: November 15th, 2023
- Conference payment fee: Before November 15th, 2023
- Session schedule announcement: November 20th, 2023
- Conference day: December 8&9th, 2023
- Full paper submission for publication: December 30th, 2023

Contact

Faculty of Physics and Engineering
Physics (Building A):
Email: 4iceba2023@gmail.com
website:
phys.hcmus.edu.vn/ICEBA2023/#/

The purpose of the 4th ICEBA2023 is to link the researchers, scientists from Vietnam, Australia and Asian countries in the field of Engineering Physics and microelectronics and semiconductors for their applications in biomedical engineering, health sciences, hi-tech agriculture and smart cities. Besides, we also contribute to promoting international cooperation activities on joint research projects and international co-publications.

The subject areas: Contributed papers must be the new research works and are solicited in the following subject areas (but not limited to):

- *Applied Physics, Engineering Physics, Electronic Engineering and Nuclear Engineering;*
- *MEMS (MicroElectronMechanical System), Sensors, Biosensors and semiconducting devices;*
- *Microelectronics, IC design, low consumption devices, Renewable Energy*
- *Computing Science, Simulations and Modeling;*
- *Embedded systems, Internet of Things, Machine Learning, Artificial Intelligence,..*
- *Biomedical Engineering, Digital Microfluidics and their applications;*

Please submit your registration and abstract (around 200 words) via website or 4iceba2023@gmail.com before **October 30th, 2023**.

Full paper for peer-review process for presentation (as template) must be submit before **November 15th, 2023**.

Publications: The selected papers (from 4 to 8 pages) will be reviewed or recommended for the publications in one of the below Scopus/SCIE/Scimago database Journal *with your submission and payment* such as:

- (1) *IEEJ Transactions on Electrical and Electronic Engineering (Q3);*
- (2) *IEEJ Transactions on Sensors and Micromachines (Q4) ;*
- (3) *Applied Sciences (MDPI, Q1/Q2);*
- (4) *Special Issue of Nanomaterials (MDPI, Q1)*

Host: VNUHCM-University of Science and Tohoku University (Japan).

Technical Supports: IEEE Vietnam Section, Institute Electrical Engineer of Japan (IEEJ), Institute of Korean Electrical & Electronic Engineers (IKEEE) and HoChiMinh Semiconducting Industrial Association (HSIA).

*Co-organizers



*Technical Support



The 4th International Conference on Engineering Physics, MEMS-Biosensors and Applications (ICEBA2023)

VNUHCM-University of Science, December 8-9, 2023

Venue: 227 Nguyen Van Cu Street, District 5, Ho Chi Minh City, Vietnam

AGENDA OF ICEBA2023



***1st day of Conference (December 8, Friday)**

Time	Contents/Program	Note
07:30-08:45	Registration (Check list, nameplate, Abstract&Program,...)	-Lobby of conference room: Building I, University of Science, HCM city, Vietnam. -The secretary
1.OPENING CEREMONY & PLENARY SESSION		
Conference Hall I, Building I, 227 Nguyen Van Cu Str., District 5		
09:00-09:10	1. Introduce Guests (MC)	MC: Dr. Ho Thanh Huy (VNUHCM-US)
09:10-09:25	2. Welcome speeches: - Welcome speech from the president of VNUHCM-US; - Speech from Co-General Chair of 4 th ICEBA2023: <i>Prof. Takahito Ono and Prof. Nguyen Van Hieu;</i> - Speech from Program Chair of 4 th ICEBA2023: <i>Prof. Huynh Van Tuan.</i>	
09:25-09:35	3. Offer the gifts for invited speakers . Plenary invited talks. . Invited talks	VNUHCM-US
09:40-09:50	4. Announcement the plan for the 5th ICEBA2024 in Vietnam and 6th ICEBA2025 Conference in Taiwan	Program Committee of ICEBA2023, VNUHCM-University of Science; Tohoku University-Ono/Toda Lab; National Central University (Taiwan) and other guests.
09:50-10:00	Coffee break	Lobby
10:00-11:50	5. Plenary invited talk Session: 15 min for talk and 5 min for discussion <i>Chair: Prof. Takahito Ono (Tohoku University, Japan)</i> <i>Co-Chair: Prof. Nguyen Van Hieu (VNUHCM, Vietnam)</i> Link google meet for online: https://meet.google.com/zeb-ddeo-ukh	
10:00-10:20	. Plenary #1 (code: PL-01). Prof. Takahito Ono <i>Tohoku University, Japan</i>	Micro/Nanosensors for Healthcare Applications
10:20-10:40	. Plenary #2 (code: PL-02) (online) Prof. Dao Viet Dzung <i>Griffith University, Australia</i>	High Performance MEMS Sensors
10:40-11:00	. Plenary #3 (code: PL-03) Prof. Kyeong-Sik Min <i>Kookmin University, Seoul, Korea</i>	Energy-efficient AI computing hardware by processing in memory and local learning
11:00-11:15	. Plenary #4 (code: PL-04) (online) Dr. Pham Thanh Trung <i>NISM, University of Namur, Belgium</i>	New transfer technique for graphene and other 2D materials on Si substrates for electronic devices

The 4th International Conference on Engineering Physics, MEMS-Biosensors and Applications (ICEBA2023)

VNUHCM-University of Science, December 8-9, 2023

Venue: 227 Nguyen Van Cu Street, District 5, Ho Chi Minh City, Vietnam

11:15-11:30	. Plenary #5 (code: PL-05) (online) Prof. Congo Tak Shing Ching <i>National Chung Hsing University, Taiwan</i>	Biological matter recognition using micro-interdigitated electrode array and electrical impedance spectroscopy
11:30-11:50	. Plenary #6 (code: PL-06) Prof. Kun-Yu Lai <i>DOP, National Central University, Taiwan</i>	InGaN quantum well: A new material for surface-enhanced Raman spectroscopy

**2. POSTER SESSION 11:40-12:30;
Lobby of Conference Hall I, Building I, 227 Nguyen Van Cu Str., District 5**

- Chair: Prof. Vu Thi Hanh Thu (VNUHCM-US, Vietnam);
- Co-Chair: Dr. Nguyen Quang Khoi (VNUHCM-US, Vietnam); Dr. Tran Le Giang (VNUHCM-IU, Vietnam)
- Technical Assistant: Huynh Thanh Nhan-MSc

From Session 1	S1.01-P, S1.02-P, S1.03-P, S1.04-P, S1.05-P, S1.06-P, S1.07-P, S1.08-P;
From Session 2	S2.01-P, S2.02-P, S2.03-P, S2.04-P, S2.05-P, S2.06-P;
From Session 3	S3.01-P, S3.02-P, S3.03-P;
From Session 4	S4.01-P, S4.02-P, S4.03-P;
From Session 5	S5.01-P, S5.02-P, S5.03-P;
From Session 6	S6.01-P, S6.02-P, S6.03-P;

Lunch time (12:30-13:30)

3. PARALLEL SESSION: 14:00-16:30

Invited talk: 20 min (15 min for talk and 5 min for discussion);

Oral presentation: 15min (12 min for talk and 3 min for discussion)

Session 1. Applied Physics, Engineering Physics, Nuclear Engineering

Room B40 (4th floor, Building B), 227 Nguyen Van Cu Str., District 5, HCMC

- Chair: Prof. Vo Luong Hong Phuoc (VNUHCM-University of Science, Vietnam)

- Co-Chair: Asst. prof. Vu The Dang (Osaka Metropolitan University, Japan)

- Secretary: Nguyen Duy Khanh

<i>Schedule</i>	<i>Name of invited speakers</i>	<i>Title of talks</i>
14:00-14:20	Invited talk S1-01-I <i>Prof. Vo Luong Hong Phuoc</i> (VNUHCM-US, Vietnam)	Developing a Smart Water Quality Monitoring System Using IoT Technologies
14:20-14:40	Invited talk S1-02-I <i>Asst. prof. Vu The Dang</i> (Osaka Metropolitan University, Japan)	Application of energy-resolving neutron imaging to major-component analyses of materials using four-channel superconducting detector.

The 4th International Conference on Engineering Physics, MEMS-Biosensors and Applications (ICEBA2023)

VNUHCM-University of Science, December 8-9, 2023

Venue: 227 Nguyen Van Cu Street, District 5, Ho Chi Minh City, Vietnam

14:40-14:55	Oral S1-01-O Doan Thi Thanh Nhan	Self-absorption correction, gross-alpha radioactivity measurements using gas proportional counter
Coffee break (15:00-15:15)		
15:15-15:30	Oral S1-02-O Nguyen Bui Trung Kien <i>VNUHCN- University of Science</i>	Strain Effect on the Anomalous Hall Conductivity of Fe bcc
15:30-15:45	Oral S1-03-O Pham Nguyen Duy Phuong	Interpretation of logging while drilling (LWD) documentation at the gray well, East mine Cuu Long Basin.
15:45-16:00	Oral S1-04-O Doan Thi Thanh Nhan	Preliminary study on radon concentrations in the South Plain of Vietnam's groundwater aquifers. Concentrations of radon in Tien Giang province's groundwater aquifers
16:00-16:15	Oral S1-05-O Nguyen Duc Anh	Simulating Climate Impacts on Rice Agroecosystems in An Giang Province: Pests, Yield, and Resources
16:15-16:30	Oral S1-06-O Huynh Thanh Tuan	The influence of water- based drilling mud and oil-based drilling mud on well logging in Nam Con Son Basin.
<p>Session 2. Semiconductor Technologies, Materials, Device and Related Room B41 (4th floor, Building B), 227 Nguyen Van Cu Str., District 5, HCMC - Chair: Prof. Le Vu Tuan Hung (VNUHCM-US, Vietnam); - Co-Chair: Prof. Kun Yu Lai (NCU-Taiwan) and Prof. Nguyen Hoang Nam (Hanoi VNU-University of Science, Vietnam) - Secretary: Nguyen Anh Thu</p>		
14:00-14:20	Invited talk S2-01-I <i>Prof. Le Vu Tuan Hung (VNUHCM-US, Vietnam)</i>	Role of semiconductor and metal nanoparticles heterojunction in enhancing the SERS signal for detection the banned chemical trace in food, drug, and cosmetic.
14:20-14:40	Invited talk S2-02-I <i>Dr. Nguyen Quang Khoi (VNUHCM-US, Vietnam)</i>	Study of steady state thermal model for white LEDs thermal management application at encapsulant level
14:40-15:00	Invited talk S2-03-I <i>Prof. Nguyen Hoang Nam (Hanoi VNU-University of Science, Vietnam)</i>	Development of wound healing techniques using stem-cell spray gun and bio-nanomembranes
Coffee break (15:00-15:15)		
15:15-15:30	Oral S2-01-O Dr. Nguyen Van Men (AGU)	Plasmon properties in spin polarized double-layer graphene structures
15:30-15:45	Oral S2-02-O Dr. Nguyen Thi Thanh Van	Design and numerical analysis of an active Micro-T sinusoidal mixer with integrated microelectrode cavity.
15:45-16:00	Oral S2-03-O Dr. Do Duc Cuong	Large Enhancement of Intrinsic Spin Hall Conductivity of β -W Based Alloys
16:00-16:15	Oral S2-04-O Cu Duy Thanh (NCU- Taiwan)	High-Reflectivity Mo/Si Multilayer Mirrors for EUV Applications Fabricated by Ion Beam Sputtering

The 4th International Conference on Engineering Physics, MEMS-Biosensors and Applications (ICEBA2023)

VNUHCM-University of Science, December 8-9, 2023

Venue: 227 Nguyen Van Cu Street, District 5, Ho Chi Minh City, Vietnam

Session 3. MEMS, Biosensors and Application Room B42 (4 th floor, Building B), 227 Nguyen Van Cu Str., District 5, HCMC - <i>Chair: Prof. Nguyen Van Toan (Tohoku Univ, Japan);</i> - <i>Co-Chair: Prof. Nguyen Van Hieu (VNUHCM, Vietnam);</i> - <i>Secretary: Nguyen Hoang Quan-MSc</i>		
14:00-14:20	Invited talk S3-01-I <i>Prof. Nguyen Van Hieu (VNUHCM, Vietnam)</i>	Using ML for determine the optimal size of the heat sink for high performance of Thermoelectric generators (TEGs) in the Aquaponic farm.
14:20-14:40	Invited talk S3-02-I <i>Prof. Nguyen Van Toan (Tohoku Univ.-Japan)</i>	Nanoengineered micro-supercapacitors for self-powered wireless sensing systems
14:40-15:00	Invited talk S3-03-I <i>Dr. Hitoshi Nishino (Tamagawa Holdings Co., Japan)</i>	A high-precision 3-dimensional micro-mirror actuated by piezo-actuators
Coffee break (15:00-15:15)		
15:15-15:30	Oral S3-01-O (online) <i>Dr. Sura Nguyen (THSM, Mexico)</i>	Characterizing joule heating effects on carbon nanofibers: Calculating the temperature coefficient of resistance for precise nanostructure growth control
15:30-15:45	Oral S3-02-O <i>Zhijian Zhao (Japan)</i>	High-sensitivity magnetic field sensor using magnetic torque
15:45-16:00	Oral S3-03-O <i>Yi-Hsiu KAO (Japan)</i>	Enzyme-based Chemiresistive Creatinine Biosensor
16:00-16:15	Oral S3-04-O <i>Nguyen Hoang Quan</i>	TEG-self-powered system for wireless sensing node in Aqua-green-house
16:30-16:45	Oral S3-05-O <i>Dr. Tran Ngoc Dang Khoa (IUH)</i>	A novel design for a MEMS shock sensor with two thresholds.
Session 4. Microelectronics, Embedded System and AI&IoT Room E 205 (2 nd floor, Building E), 227 Nguyen Van Cu Str., District 5, HCMC - <i>Chair: Prof. Kyeong-Sik Min (KMU, Korea)</i> - <i>Co-Chair: Dr. Nguyen Chi Nhan (VNUHCM-US, Vietnam) and Prof. Jongsun Kim (Hongik University, Korea)</i> - <i>Secretary: Nguyen Phuoc Hoang Khang-MSc</i>		
14:00-14:20	Invited talk S4-01-I <i>Prof. Hoang Trang (VNUHCM-UT, Vietnam)</i>	A Novel Framework, methods of AI to Optimize in Designing Analog IC
14:20-14:40	Invited talk S4-02-I <i>Dr. Nguyen Chi Nhan (VNUHCM-US, Vietnam)</i>	Predicting the content of toxic substances in aquaculture water using machine learning approaches
14:40-15:00	Invited talk S4-03-I <i>Prof. Truong Ngoc Son (HCM University of Technology and Education, Vietnam)</i>	Optimized memristor crossbar array for neuromorphic computing system
Coffee break (15:00-15:15)		

The 4th International Conference on Engineering Physics, MEMS-Biosensors and Applications (ICEBA2023)

VNUHCM-University of Science, December 8-9, 2023

Venue: 227 Nguyen Van Cu Street, District 5, Ho Chi Minh City, Vietnam

15:15-15:35	Invited talk S4-04-I <i>Prof. Jongsun Kim</i> (School of Electronic & Electrical Engineering, Hongik University, Korea)	Design of on-chip clock generators for energy efficient chiplet-based systems
15:35-15:50	Oral S4-01-O Nguyen Hoang Trong	An Efficient Design of 45nm Charge-Pump Phase-Locked Loop Architecture for Sub-1G IoT Applications
15:50-16:05	Oral S4-02-O Lu Trung Tin	Enhanced Fuzzy Logic Control for Overcoming Intrinsic Resistance in Inverted Pendulum Systems
16:05-16:20	Oral S4-03-O Phan Tan Phuc	Optimizing Solar Energy Efficiency in Zero Energy House: An Incremental Conductance MPPT-Based Approach
16:20-16:35	Oral S4-04-O Tran Thi Linh	Naturalistic Driving Action Recognition and Driver Drowsiness Detection System
16:35-16:50	Oral S4-05-O Lam Hong Phuc	Energy Management Strategy for Decarbonized Energy Sources in DC Residential Microgrid

Session 5. Computing Science, Simulation and Modeling

Room E.206 (2nd floor, Building E), 227 Nguyen Van Cu Str., District 5, HCMC

- Chair: Prof. Huynh Van Tuan (VNUHCM-US, Vietnam)

- Co-chair: Dr. Do Duc Cuong (VNUHCM-US, Vietnam)

- Secretary: Dr. Trinh Thi Ly

14:00-14:20	Invited talk S5-01-I <i>Dr. Vo Hong Hai</i> (VUHCM-US)	Development of an FPGA-Based Pulse-Height Analyzer for Scintillation Detectors in Gamma Energy Spectroscopy
14:20-14:35	Oral S5-01-O <i>Dr. Le Nguyen Hoa Tien</i>	Calculating the Wave Propagation in Cu Lao Dung Mangrove Forest (Soc Trang) using WAPROMAN model
14:35-14:50	Oral S5-02-O Nguyen Duy Thong	Estimation of thickness samples using gamma scattering techniques based on Machine learning approach

Coffee break (15:00-15:15)

15:15-15:30	Oral S5-03-O Huynh Quoc Viet	Applied the Maximal Overlap Discrete Wavelet Transform and Short Time Fourier Transform layers for classify the electroencephalography of schizophrenia patients
15:30-15:45	Oral S5-04-O Phan Tung Anh	Optimization of power calculation using LQR control, stability analysis with Lyapunov Equation and Sensor fault monitoring for Wind Turbines
15:45-16:00	Oral S5-05-O Tran Hoang Nhut	Detection and diagnosis of rice leaf disease using deep convolutional neural network.

Session 6. Biomedical Engineering and Medical devices

Room B.43 (4th floor, Building B), 227 Nguyen Van Cu Str., District 5, HCMC

- Chair: Prof. Pham Thi Thu Hien (VNUHCM-UI, Vietnam)

The 4th International Conference on Engineering Physics, MEMS-Biosensors and Applications (ICEBA2023)

VNUHCM-University of Science, December 8-9, 2023

Venue: 227 Nguyen Van Cu Street, District 5, Ho Chi Minh City, Vietnam

- <i>Co-Chair: Dr. Huynh Chan Khon (VNUHCM-IU, Vietnam)</i>		
- <i>Secretary: Nguyen Thi Tu Trinh</i>		
14:00-14:20	Invited talk S6-01-I <i>Prof. Pham Thi Thu Hien (VNUHCM-UI, Vietnam)</i>	Detection and classification of breast cancer utilizing polarization images and artificial intelligence (AI) model
14:20-14:40	Invited talk S6-02-I <i>Dr. Huynh Chan Khon (VNUHCM-IU, Vietnam)</i>	Development of electrowetting on dielectric based digital microfluidic platform toward automated molecular biology assay
14:40-14:55	Oral S6-01-O Dinh Thanh Dat	A Novel Cancer Cells Recognizer Tracking Starvation-Induced Lipid Trafficking into Mitochondria
Coffee break (15:00-15:15)		
15:15-15:30	Oral S6-02-O Hua Thi Hoang Yen	Denoising And Enhancing Image Quality For Detection Accuracy In Mammograms
15:30-15:45	Oral S6-03-O Le, Thi Thu Ngoc (Taiwan)	Maintaining the Postharvest Fruit Quality using UV-C LED System
15:45-16:00	Oral S6-04-O Phan Thien Luan (Taiwan)	Development of a handheld impedance analyzer using AD5941
4. MEETING OF PROGRAM COMMITTEE FOR ICEBA2024		
* Time: 17:00-17:30		
* Location: Room B40, Building B, 227 Nguyen Van Cu Str., District 5, HCMC		
* Participant: Scientific committee, Program committee, Local committee and other guests		
5. DINNER PARTY OF ICEBA2023 CONFERENCE		
* Time: 18:00-20:00 (<i>Departure at 17:45 by walk</i>)		
* Location: 241 Restaurant (45 Pham Viet Chanh Str., District 1, HCM city)		
* Participant: VIP guests, Invited speakers, Scientific Committee, Program Committee, Local Committee, Participants,...		
*Program: the summary of ICEBA2023, poster prize, thanks gifts, closing remark and dinner.		

***2nd day of Conference (December 9, Saturday)**

<i>Time</i>	<i>Title and Program</i>	<i>Contents and note</i>
07:30-07:50	Registration	Lobby of E.303 (Building E, 3 rd floor)
1. TUTORIAL SESSION (for teaching assistants, students, engineers,...)		
Room 303 (3 rd floor, Building E), 227 Nguyen Van Cu Str., District 5, HCMC		
- <i>Chair: Prof. Nguyen Van Toan (Tohoku University)</i>		
- <i>Technical Assistant: Mr. Tran Hoang Nhut and Ms. Nguyen Ngoc Thao Nhi</i>		
08:00-09:00	Tutorial #1. <i>Prof. Nguyen Van Toan (Tohoku University)</i>	Nanoengineered Microsystems: Concepts, Examples, and Applications
09:00-10:00	Tutorial # 2. <i>Prof. Kyeong-Sik Min (KMU, Korea)</i>	Energy-efficient AI computing hardware by processing in memory and local learning
2. CITY TOUR: (Optional)		

The 4th International Conference on Engineering Physics, MEMS-Biosensors and Applications (ICEBA2023)

VNUHCM-University of Science, December 8-9, 2023

Venue: 227 Nguyen Van Cu Street, District 5, Ho Chi Minh City, Vietnam

ABSTRACT & PROGRAM ICEBA2023

The 4th International Conference on
Engineering Physics, MEMS-Biosensors
and Applications

Host by

*VNUHCM-University of Science (Vietnam)
& Tohoku University (Japan)*



VNUHCMUS-University of Science, Vietnam

December 8-9, 2023

Organization



HCMUS
HO CHI MINH CITY UNIVERSITY OF SCIENCE



東北大学
TOHOKU UNIVERSITY

Technical Supports



INSTITUTE OF KOREAN
ELECTRICAL AND
ELECTRONICS ENGINEERS



The 4th International Conference on Engineering Physics, MEMS-Biosensors and Applications (ICEBA2023)

VNUHCM-University of Science, December 8-9, 2023

Venue: 227 Nguyen Van Cu Street, District 5, Ho Chi Minh City, Vietnam

CONTENTS

1. Plenary Invited talk Session

2. Parallel Sessions

*Session 1. Applied Physics, Engineering Physics, Nuclear Engineering

*Session 2. Semiconductor Technologies, Materials, Device and Related

*Session 3. MEMS, Biosensors and Application

*Session 4. Microelectronics, Embedded System and AI&IoT

*Session 5. Computing Science, Simulation and Modeling

*Session 6. Biomedical Engineering and Medical devices

3. Poster Session

4. The 5th International Conference on Engineering Physics,

MEMS-Biosensors and Applications (ICEBA2024)

PLENARY INVITED TALK SESSION

<i>Schedule</i>	<i>Invited Speakers</i>	<i>Title of talks</i>	
10:00-10:20	. Plenary #1 (code: PL-01). Prof. Takahito Ono <i>Tohoku University, Japan</i>	Micro/Nanosensors for Healthcare Applications	2
10:20-10:40	. Plenary #2 (code: PL-02) Prof. Dao Viet Dzung <i>Griffith University, Australia</i>	High Performance MEMS Sensors	5
10:40-11:00	. Plenary #3 (code: PL-03) Prof. Kyeong-Sik Min <i>Kookmin University, Seoul, Korea</i>	Energy-efficient AI computing hardware by processing in memory and local learning	9
11:00-11:15	. Plenary #4 (code: PL-04) Dr. Pham Thanh Trung <i>NISM, University of Namur, Belgium</i>	New transfer technique for graphene and other 2D materials on Si substrates for electronic devices	11
11:15-11:30	. Plenary #5 (code: PL-05) Prof. Congo Tak Shing Ching <i>National Chung Hsing University, Taiwan</i>	Biological matter recognition using micro-interdigitated electrode array and electrical impedance spectroscopy	14
11:30-11:50	. Plenary #6 (code: PL-06) Prof. Kun-Yu Lai <i>DOP, National Central University, Taiwan</i>	InGaN quantum well: A new material for surface-enhanced Raman spectroscopy	18

PLENARY INVITED TALK (Code: PL-01)

Micro/Nanosensors for Healthcare Applications

Takahito Ono

Department of Mechanical Systems Engineering, Tohoku University, Sendai, Japan

Email: takahito.ono.d4@tohoku.ac.jp

Abstract

Miniature healthcare sensors are useful for patients with chronic diseases. For example, patients with diabetes need continuous monitoring of blood glucose levels and require small non-invasive sensors. Micro/nanosensors for healthcare can also help in the field of preventive medicine. By collecting biometric data and assessing individual health trends and risk factors, preventive measures can be taken to prevent the onset of diseases.

We have developed non-invasive sensors and urine sensors using micro-nanofabrication technology for healthcare applications at home. Micro- and nano-mechanical transducers fabricated by microfabrication technology exhibit high mechanical Q-factors and are expected to be applied as high-sensitivity sensors. Non-invasive bio-magnetic sensors, non-invasive photoacoustic sensors and non-invasive in vivo radical sensors are being developed using these mechanical vibrators (1-4).

Bio-magnetic sensors are intended to monitor health conditions by measuring magnetic fields emitted from the heart and brain, etc. Magnetic field resolution of nT to pT need to be measured, and compact sensors that can operate at room temperature are required. We are developing a magnetic sensor in which a magnetic material is formed on the cantilever and the effective spring of the cantilever is changed by magnetic forces (1,2). The magnetic material on the cantilever changes its magnetization in response to an external magnetic field, and the magnetic force between the cantilever and an external magnetic coil is changed by the "magnetic torque", resulting in a highly sensitive magnetic sensor ~ order of pT.

Magnetic forces act between the magnetic material on the cantilever and the external magnetic material, altering the mechanical response. An externally placed coil and bias magnetic field can cause magnetic resonance in radical molecules in vivo and change the spin orientation of the radicals. In this process, a force acts on the magnetic material on the transducer. This force causes a change in the amplitude of the transducer, which allows it to operate as a radical sensor (3).

Biosensors are being developed to measure biomarkers in urine with simplicity and high accuracy at home. Calorimetric biosensors, which measure the heat associated with chemical reactions, are known as one method of biosensors. Integration technology is developed for compact, highly sensitive thermistors that detect weak heat. To selectively detect specific biomarkers, we utilize enzymes and the heat associated with enzyme-catalyzed reactions. This calorimetric sensing is successfully used to detect glucose and protein (4).

A resistance-changing biosensor that uses metal nanoparticles as a resistive element is studied. The sensor uses an enzyme-modified resistive element made of a mixture of metal nanoparticles

and polymers, where the H₂O₂ produced as a result of the enzyme-catalyzed reaction is redoxed by the metal nanoparticles. The conductivity of the resistive element is changed. This method has been successfully used to detect creatinine (5).

*Keywords: Biosensor, Resonator, Magnetic sensor, Calorimetric sensor, Resistive sensor

References:

1. Z. Zhao, M. Toda, T. Ono, Highly sensitive magnetic sensor using magnetic torque, Technical digest of Sensor and Micromachine Symposium, Kumamoto, Japan, Nov. 8, 2023.
2. N. Inomata, W. Suwa, N. V. Toan, M. Toda, T. Ono, Resonant magnetic sensor using concentration of magnetic field gradient by asymmetric permalloy plates, *Microsystem Technologies*, **25** (2019) 3983-3989.
3. G. Xue, M. Toda, X. Li, X. Wang, and T. Ono, Magnetic Resonance Force Microscopy with Vacuum-Packaged Magnetic Cantilever Towards Free Radical Detection, *IEEE Sensors Journal*, 21, 20 (2021) 22578-22586.
4. I. Latif, M. Toda, T. Ono, Hermetically Packaged Microsensor for Quality Factor-Enhanced Photoacoustic Biosensing. *Photoacoustics* 18, (2020) 100189.
5. Z. Wang, M. Kimura, N. Inomata, J. Li, T. Ono, Compact micro thermal sensor based on silicon thermocouple junction and suspended fluidic channel, *IEEE Sensors Journal*, 20, 19 (2020) 11122.
6. Y.-H. Kao, T. T. K. Tuoi, H. Sui and T. Ono, Enzyme-based Chemiresistive Creatinine Biosensor, Technical digest of Sensor and Micromachine Symposium, Kumamoto, Japan, Nov. 8, 2023.

Short- Biography

Full name: Takahito Ono., Professor, Dr. Eng.

Academic position: Professor

Job's position:

Department of Mechanical Systems Engineering Graduate School of Engineering, Tohoku University, Sendai, Japan

Micro System Integration Center (μ SiC), Tohoku University, Sendai, Japan



Contacts:

Email address:

takahito.ono.d4@tohoku.ac.jp

Handphone: (+81)90-6450-3324

Website of personal/ lab/dept:

https://www.nme.mech.tohoku.ac.jp/index_e.html

1. Research Areas:

- Nanoengineering and Nanotechnology
- Micro/Nanosensor
- Ultimate sensing university
 - Director, MicroNanomachining Research Education Center, Tohoku University
 - Executive Committee of The Electrochemical Society (ECS), USA.
 - Editorial Board, Nature Microsystems & Nanoengineering
 - Editorial board, Institute of Physics (IOP), Journal of Micromechanics and Microengineering
 - Representative Member, Japan Society of Mechanical Engineers
 - Deputy Director, IEEJ Sensors and Micromachines Division Executive Committee
 - (Invited talk) Takahito Ono, Magneto-Mechanical Micro-Nano Devices with Electrodeposited Magnetostriction Films, ECS symposium, October 8-12, 2023 – Gothenburg, Sweden. (Peer-reviewed Paper, total 310 papers)
 - (Paper) Naoki Inomata, T. Miyamoto, K. Okabe and T. Ono, Measurement of cellular thermal properties and their temperature dependence based on frequency spectra via an on-chip-integrated microthermistor, Lab on a Chip, 23 (2023) 2411-2420.
 - (Paper) H. Arisawa, H. Shim, S. Daimon, T. Kikkawa, Y. Oikawa, S. Takahashi, T. Ono, E. Saitoh, Observation of spin-current striction in a magnet, Nature Communication, 13 (2022) 2400.

4. Research Achievements and Awards:

He received Tokin Research Award from Tokin Science Foundation for the development of nanomechanical machines on 2005, also received MNC 2012 Paper Award, 15th International Microprocess and Nanotechnology Conference, IEEJ paper award 2019, Microsystem & Nanoengineering Award 2020, and IEEJ award 2022. He presented invite lectures over 60 at international conferences.

PLENARY INVITED TALK (Code: PL-02)

High Performance MEMS Sensors

Dao Viet Dzung

Advanced Sensors Lab, Griffith University, Gold Coast, Australia

E-mail: d.dao@griffith.edu.au

Abstract

MEMS technology relates to research and development of micro/nano electro-mechanically integrated sensors and actuators fabricated based on the microelectronic technology with high accuracy and throughput.

This work presents our innovative MEMS sensors developed based on Si and SiC MEMS technology. The focus will be on advanced sensing effects in semiconductor nanostructures, including piezoresistive, optoelectronic and thermoresistive effects.

Compared to Si, SiC MEMS sensors are expected to work more reliably in harsh conditions, e.g. high temperature, aggressive corrosive environments thanks to its unique properties, such as larger bandgap, higher thermal stability, higher breakdown voltage, higher Young's modulus than silicon. We recently have successfully developed mechanical, thermal and optical MEMS sensors with high sensitivity and large working temperature range [1,2]. For example, optoelectronic coupling in a SiC/Si heterojunction exhibited an ultra-high gauge factor of up to 58,000 which is the highest gauge factor reported for semiconductor-based mechanical sensors to date [1]. Interestingly, 3C/Si has been proven as a potential platform for highly sensitive and self-powered position photodetectors [3]. Our successful demonstration of mechanical, thermal and optical sensing concepts and devices could open a new door for the development of high-performance MEMS sensors from research point of view to a wide range of potential applications.

*Keywords: MEMS, Sensors, Semiconductor, Heterojunctions, Sensing effects.

*References:

- [1] T. Nguyen, et al., **Dzung V. Dao** "Giant piezoresistive effect by optoelectronic coupling in a heterojunction", *Nature communications*, vol. 10, pp. 1-8, 2019
- [2] T. Dinh, et al., **Dzung V. Dao**, "Opto-thermotronic effect as an ultrasensitive thermal sensing technology for solid-state electronics", *Science Advances*, 6(22), 2671, 2020.
- [3] A.R. Md Foisal, et al, **Dzung V. Dao**, "Ultra-sensitive self-powered position-sensitive detector based on horizontally-aligned double 3C-SiC/Si heterostructures", *Nano Energy*, 79, p.105494, 2021.

Short- Biography

Name: Dzung DAO

Phone: +61-7-555-27515; **Email:** d.dao@griffith.edu.au

Current positions

- Professor, Mechanical Engineering, Griffith University
- Director, Mechatronics Engineering Program, Griffith University



Education/Qualifications

- 2003 PhD in Electro-Mechanical Systems, Ritsumeikan University, Japan
- 1997 M.Eng Mechanical Eng., Hanoi University of Science and Technology (HUST), Vietnam
- 1995 B.Eng Informatics-Mechanical Engineering, HUST, Vietnam

Professional History

- 2017 to 4/2023: **Head**, Mechanical Engineering Discipline, School of EBE, Griffith, AUSTRALIA.
- 2021 to present: **Professor**, School of EBE, Griffith Uni, AUSTRALIA.
- 2011 to 2021: **Senior Lecturer, and A/Professor**, School of EBE, Griffith Uni, AUSTRALIA.
- 2021 to 2022: **Co-chair**, National Committee on Control Eng. & Industry 4.0, Engineers Australia.
- 2019-2021: **Chair**, National Committee on Mechatronics, Engineers Australia
- Apr 2007 to Dec 2011: **Chair Professor**, MEMS, Ritsumeikan University, JAPAN.
- Apr 2006 to Mar. 2007: **Lecturer**, MEMS, Ritsumeikan University, JAPAN.
- Apr 2003 to Mar 2006: **Postdoctoral fellow**, Ritsumeikan University, JAPAN.
- Sept 1995 to Sept 1999: **Lecturer**, Mechanical Engineering, HUST, VIETNAM.

Teaching area

- Mechanical Engineering Design, Mechatronics System Design, Electromechanics, Manufacturing Technology, Kinematics and Dynamics.

Research area

- Optoelectronic and Sensing effects in nanostructured materials, semiconductors
- Micro/Nano Electromechanical Systems (MEMS), MEMS Sensors, Actuators, energy harvesters
- Advanced Manufacturing: Micro/Nano machining technology, Additive manufacturing
- Wireless sensor network

Publications: 235 Journal papers, 190 Conference papers, 6 book/book-chapters

Publication Citations: 7150, **H-index:** 43 (Google scholar)

Patents (filed and granted): 18

Research Grants: > \$11.5M in total. Grants received within the last 5 years are shown below:

1. ARC DP, **Lead CI**, 2022-2025, "Nano optoelectronic: towards an ultrasensitive sensing", **\$585k**
2. ARC LIEF, CI, 2023, National Facility for Characterisation of Infrared Technologies, **\$690k**
3. CCR (Geoinventions), 2023, "Robust sensors for geotechnical applications", **\$35k**
4. CCR (Dentroid), 2023, "Clamping mechanism for intraoral laser manipulator", **\$25k**
5. Griffith Infrastructure, **Lead CI**, 2022 "Etching facility for MEMS sensors fabrication", **\$280k**

The 4th International Conference on Engineering Physics, MEMS-Biosensors and Applications (ICEBA2023)

VNUHCM-University of Science, December 8-9, 2023

Venue: 227 Nguyen Van Cu Street, District 5, Ho Chi Minh City, Vietnam

6. Griffith Sciences, CI, 2022, “*Integrated Quantum Efficiency Measurements System*”, **\$109k**
7. Griffith Sciences, CI, 2022, “*A set of 3D Laser Scanning Microscope System*”, **\$90k**
8. Griffith Sciences, CI, 2022, “*Transient Plane Source Thermal Conductivity Analyser*”, **\$90k**
9. ARC LIEF, CI, 2022, Facility for enabling low thermal budget Si/SiGe technologies, **\$580k**
10. IMCRC, **Lead CI**, 2021-2022, “*Smart sensor system for soft soil engineering & safety*”, **\$125k**
11. IMCRC, **Lead CI**, 2021-2022, “*Miniaturised laser manipulator for ultra-precise dentistry*”, **\$225k**
12. ARC LIEF, CI, 2021, “*Femtoliter Liquid Deposition Facility*”, **\$183k**
13. CSIRO-DFAT, **Lead CI**, 2020-2022, “*Low-power Wireless Flood Sensor Network*”, **\$400k**

14. CCR (Dentroid, Australia), **Lead CI**, 2020-2022, **\$30k**
15. IMCRC, CI, 2020-2022, “*R2R printing for cost effective manufacturing of a Smart Patch for health monitoring*”, **\$1,436,437**
16. CCR (Industry: Overseas), CI, 2019-2020, “*Ultra-sensitive pressure sensor*”, **\$110k**
17. Foundation for Australia-Japan Studies (FAJS) grant, **lead CI**, 2019-2020, “*Superior Sensor Network (SSN) for Harsh Environments*”, **\$145,000**
18. Griffith Science Equipment round, **lead CI**, 2019, “*Opto-Electro-Mechanical Measurement Suite*”, **\$165,000**
19. ARC LIEF project, CI, 2019, “*A femtosecond laser micromachining facility*”, **\$438k**
20. Griffith University Infrastructure Grant, CI, 2019 (CI): **\$385k**
21. Griffith University Infrastructure Grant, CI, 2019 (CI): **\$323k**
22. ARC DP, CI, 2018-2021, “*Magnetofluidic sample handling for enhanced PoC diagnosis*”, **\$473k**
23. ARC LP, **Lead CI**, 2017-2021, “*Superior Silicon Carbide Nanoscale Sensors (SCANS) for Harsh Environments*”, **\$563,000** (\$160,000 from SPT Microtechnologies, USA)
24. IMCRC project, CI, 2017-2022, “*Develop and manufacture a smart electric compressor*”, **\$850,000** (50% from industry partner: SuperCool Australia)
25. ARC LIEF, CI, 2018, “*Xe-plasma dual beam for advanced future materials*”, **\$1,136k**
26. Griffith University Infrastructure Grant (CI, 2017): **\$115k**

HDR Supervision: I have successfully supervised to completion of 25 PhD students, all of them have secured good jobs in academia and industry. Notably, 3 of my recent graduates were awarded DECRA.

Awards/Recognition

- World's top 2% most-cited scientists in Applied Physics (Stanford rankings 2021-2022)
- Top 1 researcher worldwide for publications & citations in *SciVal Topic Cluster of Pressure Sensors, Sensors*.
- Vice Chancellor's Research Excellence Award – Excellent Research Team, 2021
- Pro Vice Chancellor's Research Excellence Award – Excellence of Research Group, 2020
- Best Paper Award, 5th SDM, Gold Coast, Australia, 6/2018.
- Gold Coast City Mayor Award for outstanding contribution to Gold Coast City, 2016
- Best Oral Presentation Award, ICNNE 2016, Paris, France, 6/2016.
- Best Paper Award, 5th Bio4Apps, Gold Coast, Australia, 12//2016.
- Best Paper Award, IEEE MHS2008, Nagoya, Japan, 10/2008.
- Best Student Paper Award, APCOT2006, Singapore, 2006

Industry Collaborations

- 2021-present, Geoinventions, Australia. Total funds received: **\$160k**
- 2020-present, Dentroid. Total funds received: **\$250k**

The 4th International Conference on Engineering Physics, MEMS-Biosensors and Applications (ICEBA2023)

VNUHCM-University of Science, December 8-9, 2023

Venue: 227 Nguyen Van Cu Street, District 5, Ho Chi Minh City, Vietnam

- 2019-2020, Rio Tinto (sponsor through the Foundation for Australia-Japan Studies). Project "Superior Sensor Network (SSN) for Harsh Environments". Total funds: **\$145k**
- 2017-2020, SPT Microtechnologies (USA) in my ARC LP "Superior Silicon Carbide Nanoscale Sensors (SCANS) for Harsh Environments".
- 2017-2020, SuperCool Asia Pacific Pty Ltd (Australia) in the Innovative Manufacturing CRC Project "Develop and manufacture a smart electric compressor for refrigeration and air conditioning on electric vehicles".
- From 2003 to 2011, I collaborated with various companies in Japan to conduct R&D projects. These companies are Olympus Corp, Omron Corp, Konica-Minolta Inc, Tamagawa Seiki, Horiba Corp, Towa Corp, Microstone, and Tokairika Co Ltd.

Through these collaborations, I gained valuable experience working with industry professionals and was able to apply my research to real-world applications.

Editorial Board and Professional Committees

- Discipline Expert (Mechanical & Mechatronics), EA Accreditation Panel, since 2015
- Associate Editor, Sensors and Materials, MYU KK, Tokyo, Japan
- Editorial Board Member, J. Adv. Nat. Sci: Nanosci. Nanotechnol., IOP, UK.
- Editorial Board Member, Sensors Journal, MDPI
- Editorial Board Member, J. Sensors, Hindawi Publishing Corporation.
- General Chair of the 5th Bio4Apps,2016, Gold Coast, Australia
- General Chair, 5th Int'l Conf. on Sustainable Design and Manufacturing, Australia, June 2018.

PLENARY INVITED TALK (Code: PL-02)

Energy-efficient AI computing hardware by processing in memory and local learning

Kyeong-Sik Min

School of Electrical Engineering, Kookmin University, Seoul, Korea

E-mail: mks@kookmin.ac.kr

Abstract

Large Language Models (LLMs) such as GPT-4 are coming to our daily lives with excellent performance and infinite potential in the field of artificial intelligence. Their enormous size models should deal with a tremendous level of computational workloads that have never been experienced before. The heavy computation needs a huge amount of energy consumption that makes it impossible to sustain the LLMs in terms of computing energy efficiency in future.

How can we improve the computing energy efficiency to keep the LLM's energy consumption within a sustainable level? After the slowing down of Moore's law and the end of voltage scaling, one way of reducing the computing energy is decreasing a physical distance between computing and memory units. Processing using memory or processing near memory can be useful to improve the computing energy efficiency by shortening the distance between the logic and memory parts. To explain this in detail, we review various memories including SRAMs, DRAMs, RRAMs, etc. for processing near and using memories to implement AI computing hardware, as conceptually indicated in Figures (a) and (b). Another way of energy-efficient AI computing is replacing the backpropagation algorithm with the local learning one. By doing so, the computational workload of training can be reduced drastically. Based on the discussion above, we can predict what technologies are needed and what direction they should evolve for implementing future AI hardware and summarize this talk.

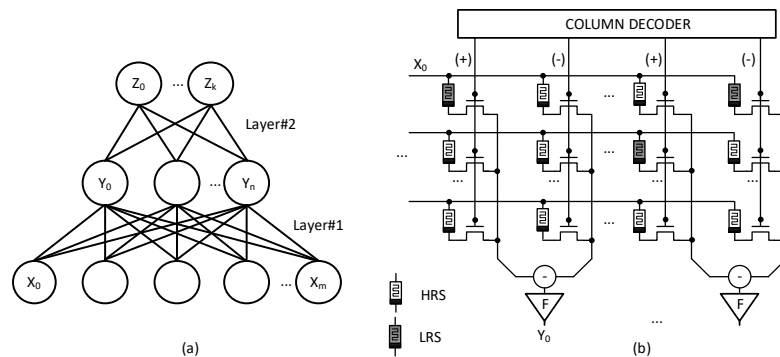

Figure 1. (a) the conceptual diagram of neural networks
(b) the emerging memory crossbar for realizing neural networks

*Keywords: Processing near memory, processing using memory, AI applications, emerging memories, energy-efficient computing

Acknowledgements: The work was financially supported by NRF-2022R1A5A7000765, NRF-2021R1A2C1011631, and NRF-2021M3F3A2A01037972. The CAD tools were supported by IC Design Education Center (IDEC), Daejeon, Korea.

Short- Biography

Full name: Kyeong-Sik Min, Professor, Ph.D.

Academic position: Professor

Job's position: School of Electrical Engineering, Kookmin University, Seoul, Korea



1. Research Areas:

- Processing in memory
- Neuromorphic circuits and systems
- Memory circuits and systems

2. Education:

(month/year to month/year, university/institute, country)

- Post doc: 12/2001-08/2002, University of Tokyo, Japan
- Ph.D: 03/1993-08/1997, KAIST, Korea
- Master: 03/1991-02/1993, KAIST, Korea.....
- Bachelor/Engineer: 03/1987-02/1991, Korea Univ., Korea

3. Academic Activities:

Members of academic society (name of society, position, where, when)

1. Distinguished Service Award from Korea Semiconductor Industry Association (KSIA), Oct. 2023
2. President of Institute of Korean Electrical and Electronics Engineers (IKEEE), 2022
3. Chairperson of SoC Research Group in Institute of Electronics and Information Engineers (IEIE), 2021
4. Award of Excellence in Academy-Industry R&D Cooperation from Mayor of Seoul City, 2021
5. Grand Prize in Haedong Best Paper Award, IEIE, Journal of Semiconductor Technology and Science (JSTS), 2020
6. Distinguished Service Award from Ministry of Science and ICT of Korean Government, 2020
7. Academic Achievement Award, Institute of Korean Electrical and Electronics Engineers, Korea, 2015
8. Distinguished Service Award, Institute of Korean Electrical and Electronics Engineers, Korea, 2014
9. Chip Design Contest Award at Korean Conference on Semiconductors, 2012
10. CAD & Design Methodology Award at Korean Conference on Semiconductors, 2011
11. Chip Design Contest Award at Korean Conference on Semiconductors, 2011
12. Distinguished Service Award, Institute of Electronics and Information Engineers, Korea, 2011-...

Contacts:

Email address:

mks@kookmin.ac.kr

PLENARY INVITED TALK (Code: PL-04)

New transfer technique for graphene and other 2D materials on Si substrates for electronic devices

Pham Thanh Trung

*Lab for physics of electronic materials, Namur Institute of Structured Matter (NISM),
Department of Physics, University of Namur, Belgium
E-mail: trung.phamthanh@unamur.be*

Abstract

Graphene has been proposed as a promising alternative to silicon-based electronics due to its outstanding electrical, optical, thermal, and mechanical properties [1-4]. It opens up new possibilities not only for fundamental physics research but also for applications. Since silicon is still the most important single-crystal substrate used for semiconductor devices and integrated circuits, integration of graphene into the current Si technology is highly desirable. A combination of graphene and silicon may overcome the traditional limitations in scaling down of devices that silicon based technology is facing [5]. In this context, graphene on Si might be one of the most promising candidates as a material for graphene-based technology beyond CMOS. Therefore, it is crucial to find a process to grow or transfer graphene directly on Si. However, direct growth of graphene on Si produces very poor crystalline quality and it is difficult to build vertical heterostructures.

To date, significant advances in graphene synthesis methods have been made and in particular, CVD (chemical vapor deposition) can produce graphene films with high structural quality on copper substrates (copper foils are commonly used for their low cost and high availability) [6, 7]. To expand the possible applications, chemical vapor deposition grown graphene needs to be transferred to appropriate substrate such as silicon wafer. Although enormous efforts are devoted to transfer graphene on various substrates using many different methods, the quality of the final product is still insufficient. In this context, we develop a new process under a combination of wet etching and dry transfer to obtain graphene on Si with a clean interface between the graphene and the substrate. Using various analysis techniques such as low energy electron diffraction, scanning electron microscopy, scanning tunneling microscopy/spectroscopy, Raman, Auger electron spectroscopy and X-ray photoelectron spectroscopy, we demonstrate that our transferred graphene on Si is continuous, clean and that it is very promising for device fabrication.

*Keywords: Graphene, 2D materials, graphene transfer, graphene on Si

*References:

- [1] K. Novoselov, A. K. Geim, S. Morozov, et al., Two-dimensional gas of massless Dirac fermions in graphene, *Nature* 438, 197 (2005).
- [2] R. R. Nair, P. Blake, A. N. Grigorenko, et al., Fine Structure Constant Defines Visual Transparency of Graphene, *Science* 320, 1308 (2008).

- [3] A. A. Balandin, S. Ghosh, W. Bao, et al., Superior thermal conductivity of single-layer graphene, *Nano Letters* 8, 902 (2008).
- [4] C. Lee, X. Wei, J. W. Kysar, and J. Hone, Measurement of the elastic properties and intrinsic strength of monolayer graphene, *Science* 321, 385 (2008).
- [5] K. Kim, J.-Y. Choi, T. Kim, S.-H. Cho, et al., A role for graphene in silicon-based semiconductor devices, *Nature* 479, 338 (2011).
- [6] S. Bae, H. Kim et al., Roll-to-roll production of 30-inch graphene films for transparent electrodes, *Nature Nanotechnology* 5, 574-578 (2010).
- [7] G. Deokar, J. Avila et al., Towards high quality CVD graphene growth and transfer, *Carbon* 89, 82-92 (2015).

Short- Biography

PHAM Thanh Trung, Ph.D



📍 4/202 - Rue Joseph Grafé, 5000 Namur, Belgium

☎ +32 - 487 11 62 09

✉ trung.phamthanh@unamur.be; trungpt2016@gmail.com

1. Current Job: Postdoctoral researcher

University of Namur (<https://unamur.be/>)

61-Rue de Bruxelles, B-5000 Namur, Belgium

Project: MBE synthesis and characterization of two-dimensional semiconductors

2. **Interesting research topics:** CVD, MBE, UHV techniques, electron diffraction (LEED and RHEED), XPS, SPM, Electron Microscopy

3. Awards:

1. Excellent young scientist at SHTP Nanotechnology lab, Saigon Hi-Tech Park, Vietnam (2017-2018).
2. Fellowship of Vietnam government for four-year PhD study in Belgium (2011 - 2015).
3. Research fellowship from the University of Kaiserslautern, Germany (10/2008 - 04/2009).
4. The author of a solution winning the third prize of the contest on scientific technical creation in Ho Chi Minh city, Vietnam (2004).

4. Publications:

1. Trung T. Pham, P. Vancsó, M. Szendrő, K. Palotas et al., Higher-indexed Moiré patterns and surface states of MoTe₂/graphene heterostructure grown by molecular beam epitaxy, *npj 2D Materials and Applications* **6**, 48 (2022).
2. Lai Xuan Bach, Thi-Bich-Ngoc Dao, Trung T. Pham, Robert Sporcken et al., Role of SnO₂ nanoparticles for a self-forming barrier layer on a mild steel surface in Hydrochloric acid medium containing piper betle leaf extract, *ACS Omega* **7**, 38061-38068 (2022).
3. Trung T. Pham, Roshan Castileno, Alexandre Felten, Robert Sporcken, Study of surface oxidation and recovery of clean MoTe₂ films, *Surfaces and Interfaces* **28**, 101681 (2022).
4. Duong Chi Trung, Trung T. Pham, Quoc Binh Phan Minh et al., The use of Piper Betle leaf extract for forming a barrier layer on steel surface in hydrochloric acid solution, *Progress in Organic Coatings* **158**,

- 106340 (2021).
5. Thi Tan Pham, Thanh Ngoc Pham, Viorel Chihaiia, Quang Anh Vu, Thuat T. Trinh, Trung T. Pham et al., How do the doping concentrations of N and B in graphene modify the water adsorption, *RSC Advances* **11**, 19560 (2021).
 6. Trung T. Pham, Roshan Castileno, Alexandre Felten, Robert Sporcken, Preparation of single phase 2H-MoTe₂ films by molecular beam epitaxy, *Applied Surface Science* **523**, 146428 (2020).
 7. Roshan Castileno, Trung T. Pham, Alexandre Felten, Robert Sporcken, Substrate temperature dependence of the crystalline quality of MoTe₂ for the phase controlled synthesis on graphene/SiC(0001) by Molecular Beam Epitaxy, *Nanotechnology* **31**, 115702 (2020).
 8. Le Ngoc, Long; Pham Tan, Thi; Trung T. Pham; Pham Trung, Kien et al., Controllable synthesis of MoS₂/graphene low-dimensional nanocomposites and their electrical properties, *Applied Surface Science* **504**, 144193 (2019).
 9. Trung T. Pham, Quyet H. Do, Thanh K. V. Ngo, and Robert Sporcken, Direct transfer of the CVD-grown graphene on copper foils on SiO₂ substrate under supercritical CO₂ assisted-cleaning technique, *Materials Today Communications* **18**, 184-190 (2019).
 10. Trung T. Pham, Trung H. Huynh, Quyet H. Do, and Thanh K. V. Ngo, Optimum reproduction and characterization of graphene on copper foils by low pressure chemical vapor deposition, *Materials Chemistry and Physics* **224**, 286-292 (2019).
 11. Trung T. Pham, Robert Sporcken, chapter 7 in handbook of graphene: Growth, Synthesis and Functionalization edited by Edvige celasco and Alexander N. Chaika, Volume **1**, (201–248) © 2019 Scrivener Publishing LLC (book chapter).
 12. Trung T. Pham, Trung H. Huynh, Quyet H. Do, and Robert Sporcken, Stack of Graphene/Copper Foils/Graphene by Low Pressure Chemical Vapor Deposition as a Thermal Interface Material, *Journal of Electronics Materials* **47**, 7476-7483 (2018).
 13. Trung T. Pham, Robert Sporcken, Three dimensional intercalated porous graphene on Si(111), *Journal of Electronic Materials* **47**, 1575-1582 (2018).
 14. Trung T. Pham, Nguyen Dang Nam, Robert Sporcken, Surface morphology, structural and electronic properties of graphene on Ge(111) via direct deposition of solid-state carbon atoms, *Thin solid films* **639**, 84 - 90 (2017).
 15. Trung T. Pham, Robert Sporcken, Free-standing graphene intercalated nanosheets on Si(111), *Journal of IKEEE* **21**, 297-308 (2017).
 16. Trung T. Pham, Cristiane N. Santos, Frédéric Joucken, Benoît Hackens, Jean-Pierre Raskin, Robert Sporcken, The role of SiC as a diffusion barrier in the formation of graphene on Si(111), *Diamond and Related Materials* **66**, 141 - 148 (2016).
 17. Trung T. Pham, Campos-Delgado, J., Joucken, F., Colomer, J-F., Hackens, B., Raskin, J-P., Santos, C. & Sporcken, R., Direct growth of graphene on Si(111), *Journal of Applied Physics* **115**, 223704 (2014).
 18. Trung T. Pham, Joucken, F., Campos-Delgado, J., Raskin, J.-P., Hackens, B. & Sporcken, R., Direct growth of graphitic carbon on Si(111), *Applied Physics Letters* **102**, 013118 (2013).
 19. Trung T. Pham, Hien S. Dinh, Model and characteristic of a resonant tunneling nanostructure, *Journal of Technical Education Sciences* **19** (2011).
 20. Trung T. Pham, Bayer Daniela, Fabrication and characterization of the ultrafast photoconductive switch, *Journal of Technical Education Sciences* **15** (2010).
 21. Son N. Pham, Trung T. Pham, Microstrip line model by finite difference time domain, *Journal of Technical Education Sciences* **15** (2010).
 22. Dinh Sy, H., Nguyen, T. L., Le, H. M., Tran Tien, T. Trung T. Pham, Bui An, D., Huynh, T. L. T., Nguyen, L. V. T., Thi, A. T. T., Huynh, H. T., Nguyen, T. T. N., Dinh, V. N., Development of quantum device simulator NEMO-VN1, *IOP - Electronics Journals* **187**, 012088 (2009).

PLENARY INVITED TALK (Code: PL-05)

Biological matter recognition using micro-interdigitated electrode array and electrical impedance spectroscopy

Congo Tak Shing Ching

Graduate Institute of Biomedical Engineering, National Chung Hsing University, Taiwan
E-mail: tsching@nchu.edu.tw

Abstract

Nowadays, electrical potential, current, impedance, capacitance, etc. play an important role in our daily life, and these electrical parameters can actually have many applications. For example, electrical impedance spectroscopy (EIS) has been widely used for the characterization of (biological) substances. There are many applications of EIS, and the speaker cited his own research experience in applying EIS in *E. coli*. Identification and quantification, as well as characterization of microplastics.

In my *E. coli*. identification and quantification study, a biorecognition-element-free interdigitated microelectrode (ID μ E) sensor is designed and developed with good reliability and affordability. Results show that the designed sensor can identify *E. coli* with good selectivity using an impedance and capacitance of 7.69 MHz. At its optimum impedance of 1.3 kHz, the ID μ E sensor can reliably quantify *E. coli* (Figure 2) in a range of measurement ($10^{3.2}$ ~ 10^6 cfu/mL), linearity ($R^2 = 0.97$), sensitivity (18.15 k Ω /log (cfu/mL)), and limit of detection ($10^{3.2}$ cfu/mL). Therefore, the ID μ E sensor developed possesses high potential for industrial and clinical applications.

In my microplastics identification study, EIS measurements using ID μ E confirmed the accurate identification of microplastic materials in question, by using self-normalized ratio between two characteristic frequencies of 7 MHz and 8.9 MHz, $Z'_{f=7 \text{ MHz}}/Z'_{f=8.9 \text{ MHz}}$. 3-kNN classifier built with the ratio $Z'_{f=7 \text{ MHz}}/Z'_{f=8.9 \text{ MHz}}$, and $Z'_{f=8 \text{ MHz}}/Z'_{f=8.9 \text{ MHz}}$, demonstrates accuracy upto 90% for the identification of single or both microplastic types in samples (Figure 4). These results confirm impedance spectroscopy, permitting rapid identification of microplastic without labelling and skillful techniques, as a potential rapid sensor.

*Keywords: Biological matter; recognition; micro-interdigitated electrode array; electrical impedance spectroscopy

Short- Biography

Full name: Congo Tak Shing Ching, Professor, Ph.D.

Academic position: Professor

Job's position: Professor, Graduate Institute of Biomedical Engineering, National Chung Hsing University, Taichung, Taiwan



Contacts:

Email address:

tching@nchu.edu.tw

Handphone: (+886) 989572005

Website of personal:

<https://www.bme.nchu.edu.tw/members/tsching/index.htm>

1. Research Areas:

Biomedical instrumentation design, biosensors, tissue bioimpedance, biomedical electronics, biomedical optoelectronic, AIoT healthcare, assistive healthcare technologies

2. Education:

(month/year to month/year, university/institute, country)

PhD in Bioengineering, University of Strathclyde, Glasgow, UK, 2005

MPhil in Biomedical Engineering, The Hong Kong Polytechnic University, HK, 2002

BSc in Prosthetics and Orthotics (First Class Honours), The Hong Kong Polytechnic University, HK, 1999

3. Academic Activities:

Members of academic society (name of society, position, where, when)

Member, Prosthetics and Orthotics Society of Taiwan, since 2016

Life Member, Taiwan Engineering Medicine Biology Association, since 2023

Life Member, Association of Chemical Sensors in Taiwan, since 2015

Life Member, Taiwan Rehabilitation Engineering and Assistive Technology Society, 2013

Life Member, The Chinese Institute of Engineers, Since 2013

Member, IEEE, since 2010

Member, IEEE Engineering in Medicine and Biology Society, since 2010

Life Member, World Association for Chinese Biomedical Engineers, since 2009

Member, International Association of Engineers (IAENG), since 2009

Life Member, Biomedical Engineering Society of the R.O.C., since 2008

Member, The Royal Society of Edinburgh Entrepreneurs' Club, since 2005

Invited talks for International conference/workshop (name of talk, name of conference/workshop, where, when)

Keynote speaker of The International Symposium on Applied Science (ISAS 2023), 13-15 Oct 2023, Ho Chi Minh City, Vietnam

The 4th International Conference on Engineering Physics, MEMS-Biosensors and Applications (ICEBA2023)

VNUHCM-University of Science, December 8-9, 2023

Venue: 227 Nguyen Van Cu Street, District 5, Ho Chi Minh City, Vietnam

Keynote speaker of Rencontres du Vietnam: The first International Symposium of Nano Life Science: Nano Biotechnology, Biosensor, Computation (NanoBioCoM2023), 17-19 Sep 2023, ICISE, Quy Nhon, Vietnam

Keynote speaker of International Symposium on Medical Devices and Technology 2023, 27-28 Aug 2023, Johor, Malaysia

Plenary speaker of The 3rd International Workshop on Engineering Physics, IC-MEMS-Sensors and Their Applications (3rdIWEMA2022), 25-26 Nov 2022, Ho Chi Minh City, Vietnam

Keynote speaker of IEEE The 2nd International Conference on Intelligent Cybernetics Technology & Applications 2022 (IEEE ICICyTA 2022), 15-16 Dec 2022, Bandung, Indonesia

Invited speaker of International Joint Symposium on Applied Mathematics, Science and Technology, 01 Dec 2022, Taichung, Taiwan

Invited speaker of The 38th SENSOR SYMPOSIUM, 9-11 Nov 2021, Japan

Keynote speaker of The International Symposium on Applied Science 2021, 15-17 Oct 2021, Ho Chi Minh City, Vietnam

Keynote speaker of The Fifth International Conference on Biological Information and Biomedical Engineering (BIBE2021), 20-22 Jul 2021, Hangzhou, China

Keynote speaker of the 3rd International Conference on Bioscience and Medical Engineering (ICBME2021), 29-30 Jun 2021, Johor Bahru, Malaysia

Invited speaker of Distinguished Lecture Series, Universiti Teknologi Malaysia, 12 Nov 2020, Malaysia

Plenary speaker of International Convention on Rehabilitation Engineering and Technology (i-CREATe 2020), 5-7 Nov 2020, Taipei, Taiwan

Keynote speaker of International Conference on Biological Information and Biomedical Engineering (BIBE 2018), 6-8 Jul 2018, Shanghai, China

Keynote speaker of The 2nd International Conference on Biomedical and Biological Engineering (BBE2017), 26-28 May 2017, Guilin, China

Keynote speaker of The International Conference on Biological Engineering and Pharmacy (BEP2016), 9-11 Dec 2016, Shanghai, China

Keynote speaker of The International Conference on Biomedical and Biological Engineering (BBE2016), 15-17 Jul 2016, Shanghai, China

Invited speaker of The 11th Annual IEEE International Conference on Nano/Micro Engineered and Molecular Systems, 17-20 April 2016, Matsushima Bay and Sendai MEMS City, Japan

Visiting researcher/professor (university/institute, where, when)

The 4th International Conference on Engineering Physics, MEMS-Biosensors and Applications (ICEBA2023)

VNUHCM-University of Science, December 8-9, 2023

Venue: 227 Nguyen Van Cu Street, District 5, Ho Chi Minh City, Vietnam

Visiting Professor, Department of Physics and Electronic Engineering University of Science (Vietnam National University of Hochiminh City), Vietnam, 06/2019 – 07/2019

Honorary Professor, Department of Health and Physical Education The Education University of Hong Kong, Hong Kong, 11/2016 – 10/2019

Academic supervisor for master/Ph.D thesis (name of title thesis, university/institute, where, when)

4. Research Achievements and Awards:

Research projects (2010-now): Chief of Project

<https://www.bme.nchu.edu.tw/members/tsching/index.htm>

Intellectual Property

<https://www.bme.nchu.edu.tw/members/tsching/index.htm>

Research Awards

<https://www.bme.nchu.edu.tw/members/tsching/index.htm>

5. ISI/Scopus/SCIE Selected Publications (2010-Now):

<https://www.bme.nchu.edu.tw/members/tsching/index.htm>

PLENARY INVITED TALK (Code: PL-06)

A new material for surface-enhanced Raman spectroscopy

Kun-Yu Lai, Nguyen Thi-Anh Nguyet and Fan-Ching Chien

Department of Optics and Photonics, National Central University, Taoyuan, Taiwan

E-mail: kylai@ncu.edu.tw

Abstract

The extraordinary emission efficiency of InGaN quantum well (QW) has led to the thriving industry of solid-state lighting and laser diodes. Recently, the two dimensional nitride layer finds another promising application in surface-enhanced Raman spectroscopy (SERS), which is regarded as one of the most powerful biosensing technologies. In specific, the electrons confined by InGaN QWs can intensify the SERS signals by providing additional charge-transfer routes to the molecule/metal interface, as well as by inducing the localized surface plasmon resonance between the surface metal and QWs. These QW-contributed electrons allow every metal nanoparticle to be the SERS-active region (i.e. hot spot), not only increasing the Raman intensity, but also stabilizing the SERS signal. In this talk, I will share our recent studies on the SERS detection of circulating tumor DNA for cancer diagnosis. Details on spectral characterizations and the potential for clinical applications will be presented.

*Keywords: InGaN, quantum wells, SERS, DNA, cancer

*References:

- [1] Fang Yin Zhao, Nguyen Thi Anh Nguyet, Chia-Wei Tsai, Che-Men Chu, Wei-Yen Woon, Chien-Ting Wu, Kun-Lin Lin, Yo-Song Huang, Chih-Ming Wang, Fan-Ching Chien, and Kun-Yu Lai, "Catching single molecules with plasmonic InGaN quantum dots", *Adv. Opt. Mater.* **11**, 2300431 (2023).
- [2] Thi Anh Nguyet Nguyen, Ying-Lung Yu, Ya Chien Chang, Yu-Han Wang, Wei-Yen Woon, Chien-Ting Wu, Kun-Lin Lin, Cheng-Yi Liu, Fan-Ching Chien, and Kun-Yu Lai, "Controlling the electron concentration for surface-enhanced Raman spectroscopy", *ACS Photonics* **8**, 2410 (2021).
- [3] Fan-Ching Chien, Ting Fu Zhang, Chi Chen, Thi Anh Nguyet Nguyen, Song-Yu Wang, Syuan Miao Lai, Chia-Hua Lin, Chun-Kai Huang, Cheng-Yi Liu, and Kun-Yu Lai, "Nanostructured InGaN quantum wells as a surface-enhanced Raman scattering substrate with expanded hot spots", *ACS Appl. Nano Mater.* **4**, 2614 (2021).

Short- Biography

Full name: Kun-Yu Lai, Professor, Ph.D.

Academic position: Professor

Job's position:

Optoelectronic Material and Device Lab, Department of Optics & Photonics, College of Science, National Central University, Taoyuan, Taiwan



Contacts:

Email address: Kun-Yu Lai

Handphone: (+886) 963011010

Website of personal/ lab/dept:

<https://kylai.cloudweb.com.tw/>

1. Research Areas:

- Plasmonic biosensors
- LEDs
- III-nitride growth

2. Education:

(month/year to month/year, university/institute, country)

- Post doc: 8/2009 ~ 6/2011, Inst. of Photon. & Optoelect., National Taiwan University, Taiwan
- Ph.D.: 8/2005 ~ 6/2009, North Carolina State University, USA
- Master: 9/1999 ~ 12/2002, University of California, Santa Barbara, USA
- Bachelor: 9/1995 ~ 6/1999, National Chiao Tung University, Taiwan

3. Academic Activities:

Members of academic society:

- *Materials Research Society, USA, 2014*

Invited Talk:

“Label-Free Biosensors Built with Nitride-based Surface Plasmon Resonance”, *Materials Science-2016, Dubai, UAE, 2016. (invited talk)*

Visiting researcher/professor (university/institute, where, when)

- Visiting Scholar, Dept. NanoEngineering, University of California, San Diego, USA, 8/2017 ~ 7/2018.

Supervisor for Ph.D. thesis:

- High quality AlN and BN grown by MOCVD for deep UV LEDs, National Central University, Taiwan, 2020
- Design, fabrication and analysis of high-voltage thin-film GaN LEDs on ceramic substrates, National Central University, Taiwan, 2014

4. Research Achievements and Awards:

Research projects (2010-now): Chief of Project

- [1]. “A label-free linker-free detection of circulating tumor DNA by Al-decorated nanostructured InGaN quantum wells” (8/2022 ~ 7/2024)
- [2]. “Nitride Surface Enhanced Raman Scattering: A New Microarray Biochip for Nucleic-acid Detection and Biological Manufacturing” (8/2020 ~ 7/2021)
- [3]. “The DNA microarray biochips by nitride-based active surface plasmon resonance imaging” (8/2019 ~ 7/2020)

Intellectual Property

[1]. United States Patent 10976577, "Sensing Substrate, Manufacturing Method thereof, and Sensor", April 13, 2021

Books

[1]. J.R.D. Retamal, C.Y. Chen, **K.Y. Lai** and J.H. He, "ZnO-based nanostructures," Chapter 4 in Handbook of Zinc Oxide and Related Materials: Volume Two, Devices and Nano-Engineering, Taylor & Francis Group (2012) ISBN: 978-143-985-574-4.

Research Awards

[1]. Outstanding Research Awards, Dept. Optics & Photonics, National Central University (2015 ~ 2020).

5. ISI/Scopus/SCIE Selected Publications (2010-Now):

[1]. Fang Yin Zhao, Nguyen Thi Anh Nguyet, Chia-Wei Tsai, Che-Men Chu, Wei-Yen Woon, Chien-Ting Wu, Kun-Lin Lin, Yo-Song Huang, Chih-Ming Wang, Fan-Ching Chien*, and **Kun-Yu Lai***, "Catching single molecules with plasmonic InGaN quantum dots", *Adv. Opt. Mater.* **11**, 2300431 (2023). (SCI 2022 IF: 9.0, 10/100 in OPTICS)

[2]. Loganathan Ravi, Muzafar Ahmad Rather, Kun-Lin Lin, Chien-Ting Wu, Tung-Yuan Yu, **Kun-Yu Lai**, and Jen-Inn Chyi*, "Epitaxial growth of GaN/AlN on h-BN/Si(111) by metal-organic chemical vapor deposition: An interface analysis", *ACS Appl. Electron. Mater.* **5**, 146 (2023). (SCI 2022 IF: 4.7, 76/275 in ENGINEERING, ELECTRICAL & ELECTRONIC)

[3]. Thi Anh Nguyet Nguyen, Ying-Lung Yu, Ya Chien Chang, Yu-Han Wang, Wei-Yen Woon, Chien-Ting Wu, Kun-Lin Lin, Cheng-Yi Liu, Fan-Ching Chien*, and **Kun-Yu Lai***, "Controlling the electron concentration for surface-enhanced Raman spectroscopy", *ACS Photonics* **8**, 2410 (2021). (SCI 2022 IF: 7.0, 13/100 in OPTICS)

[4]. Fan-Ching Chien, Ting Fu Zhang, Chi Chen, Thi Anh Nguyet Nguyen, Song-Yu Wang, Syuan Miao Lai, Chia-Hua Lin, Chun-Kai Huang, Cheng-Yi Liu, and **Kun-Yu Lai***, "Nanostructured InGaN quantum wells as a surface-enhanced Raman scattering substrate with expanded hot spots", *ACS Appl. Nano Mater.* **4**, 2614 (2021). (SCI 2022 IF: 5.9, 97/342 in MATERIALS SCIENCE, MULTIDISCIPLINARY)

[5]. Chun-Pin Huang, Muzafar Ahmad Rather, Chien-Ting Wu, Ravi Loganathan, Ying-Hao Ju, Kun-Lin Lin, Jen-Inn Chyi, and **Kun-Yu Lai***, "Crystal transformation of cubic BN nanoislands to rhombohedral BN sheets on AlN for deep-UV light-emitting diodes", *ACS Appl. Nano Mater.* **3**, 5285 (2020). (SCI 2022 IF: 5.9, 97/342 in MATERIALS SCIENCE, MULTIDISCIPLINARY)

[6]. Chun-Pin Huang, Kapil Gupta, Chuan-Pu Liu, and **Kun-Yu Lai***, "Ultra-flat AlN grown with a pulsed H₂ etching condition", *Appl. Phys. Express* **12**, 015509 (2019). (SCI 2022 IF: 2.3, 93/160 in PHYSICS, APPLIED)

PARALLEL SESSION

Session 1. Applied Physics, Engineering Physics, Nuclear Engineering

Chair: Prof. Vo Luong Hong Phuoc (VNUHCM-University of Science, Vietnam)

Co-Chair: Asst. prof. Vu The Dang (Osaka Metropolitan University, Japan)

Secretary: Mr. Nguyen Duy Khanh

<i>Schedule</i>	<i>Speakers</i>	<i>Title of talks</i>	
14:00-14:20	Invited talk S1-01-I Prof. Vo Luong Hong Phuoc (VNUHCM-US, Vietnam)	Developing a Smart Water Quality Monitoring System Using IoT Technologies	22
14:20-14:40	Invited talk S1-02-I Asst. prof. Vu The Dang (Osaka Metropolitan University, Japan)	Application of energy-resolving neutron imaging to major-component analyses of materials using four-channel superconducting detector.	24
14:40-14:55	Oral S1-01-O Doan Thi Thanh Nhan	Self-absorption correction, gross-alpha radioactivity measurements using gas proportional counter	27
Coffee break (15:00-15:15)			
15:15-15:30	Oral S1-02-O Nguyen Bui Trung Kien VNUHCN- University of Science	Strain Effect on the Anomalous Hall Conductivity of Fe bcc	28
15:30-15:45	Oral S1-03-O Pham Nguyen Duy Phuong	Interpretation of logging while drilling (LWD) documentation at the gray well, East mine Cuu Long Basin.	29
15:45-16:00	Oral S1-04-O Doan Thi Thanh Nhan	Preliminary study on radon concentrations in the South Plain of Vietnam's groundwater aquifers. Concentrations of radon in Tien Giang province's groundwater aquifers	30
16:00-16:15	Oral S1-05-O Nguyen Duc Anh	Simulating Climate Impacts on Rice Agroecosystems in An Giang Province: Pests, Yield, and Resources	31
16:15-16:30	Oral S1-06-O Huynh Thanh Tuan	The influence of water- based drilling mud and oil-based drilling mud on well logging in Nam Con Son Basin.	32
POSTER PRESENTATION: S1.01-P, S1.02-P, S1.03-P, S1.04-P, S1.05-P, S1.06-P, S1.07-P, S1.08-P.			33-40

INVITED TALK (Code: S1-01-I)

Developing a Smart Water Quality Monitoring System Using IoT Technologies

Hong Phuoc Vo Luong, Viet Hai Le Dinh, Hoa Tien Le Nguyen and Xuan Tien Nguyen Vinh

Department of Oceanology, Meteorology and Hydrology, Faculty of Physics and Engineering Physics, University of Science, Ho Chi Minh City, Vietnam

Email: vlhphuoc@hcmus.edu.vn

Abstract

Water is essential for human survival and ecosystem health. Therefore, robust mechanisms must be implemented to monitor drinking and environmental water quality. Timely warnings about water contamination are critical for protecting public and environmental health. The Internet of Things (IoT) enables remote monitoring, data collection, and analysis of water quality. This study aims to develop a smart water quality monitoring system using Web and Mobile applications. The system measures five key water quality parameters (temperature, pH, turbidity, dissolved oxygen, and salinity). Sensors are calibrated in the lab and field to ensure data accuracy. The system provides real-time water quality assessments and early warning of contamination events to safeguard drinking and environmental water resources.

Short- Biography

Full name: VO LUONG HONG PHUOC, Ph.D.

Academic position: Associate Professor

Job's position: Faculty of Physics and Engineering Physics, University of Science , Vietnam National University - Ho Chi Minh city

The 4th International Conference on Engineering Physics, MEMS-Biosensors and Applications (ICEBA2023)

VNUHCM-University of Science, December 8-9, 2023

Venue: 227 Nguyen Van Cu Street, District 5, Ho Chi Minh City, Vietnam



Contacts:

Email:

vlhphuoc@hmcus.edu.vn

Handphone:

(+84) 094 516 1402

Website of personal:

<https://oceanology.hcmus.edu.vn/2014/04/29/pgs-ts-vo-luong-hong-phuoc/>

1. Research Areas:

Modeling and simulation on Physical oceanology; Agrometeorology

Hydrodynamics in coastal zones. rivers estuaries and mangrove forests; Sediment dynamics.

2. Education:

2006: Doctorate: Physical Oceanology, Institute of Oceanology, Polish Academy of Science.

1998: Master: Geophysics University of Science, VNU.HCM

1996: BSC: Physics University of Science, VNU.HCM

3. Academic Activities:

Members of academic society (name of society, position, where, when)

Editorial board of journal “Vietnam Journal of Marine Science and Technology”

Visiting researcher/professor (university/institute, where, when)

- June, 2023: Guest lecturer on “Ecosystem of Mangroveforests” in University of Bialystok, Poland

4. Research Achievements and Awards:

Research projects (2010-now): Chief of Project

2019- now: *Eramus++*: Deepening the knowledge on large river delta and nearshore ocean marine ecosystem in SE Vietnam.

2019-2021: *Viet Nam National University –HCMC*: Research on wave energy dissipation in mangrove forests in South Vietnam.

2014-2016: *ONR (USA)*: Hydrodynamics and sediment flux in Song Hau river and Cu Lao Dung mangrove forests (Soc Trang)

2013-2016: *NAFOSTED*: Research on litho-hydrodynamics in erosion-deposition processes in mangrove forests in Viet Nam

5. ISI/Scopus/SCIE Selected Publications (selected):

1. Pham Vu Phuong Trang, Vo Luong Hong Phuoc (2023), Analysis and Assessment of the Relationship Between Chlorophyll and Hydrodynamic Factors in Cu Lao Dung (Soc Trang), *Advances in Research on Water Resources and Environmental Systems*, Selected papers of the 2nd international conference on Geo-spatial Technologies and Earth Resources 2022, 561 – 572, Springer.

2. Andrzej Górniak, Tran Xuan Dung, Vo Luong Hong Phuoc (2022), On several hydrological and biogeochemical aspects of the Mekong River delta functioning, *International Baltic Earth Secretariat Publication No. 22, River Mouth Systems and Marginal Seas - Natural drivers and human impacts Online Conference*, December 2022.

3. Eric Bullock, Curtis Woodcock, Sergio Fagherazzi, William Nardin, Hong Phuoc Vo-Luong, Hoang Phong Nguyen (2017) Temporal patterns in species zonation in a mangrove forest in the Mekong Delta, Vietnam, using a time series of Landsat imagery. *Continental Shelf Research*, 147, 144-154

INVITED TALK (Code: S1-02-I)

Application of energy-resolving neutron imaging to major-component analyses of materials using four-channel superconducting detector

Vu The Dang, Hiroaki Shishido, Kazuya Aizawa, Takayuki Oku, Kenichi Oikawa, Masahide Harada, Kenji M. Kojima, Shigeyuki Miyajima, Tomio Koyama, Kazuhiko Soyama, Mutsuo Hidaka, Soh Y. Suzuki, Manobu M. Tanaka, Masahiko Machida, Shuichi Kawamata, Takekazu Ishida.

Speaker: Dr. Vu The Dang
*Kawamata lab, Division of Quantum and Radiation Engineering,
Osaka Metropolitan University, Japan*

Email: vuthedang@omu.ac.jp

Abstract

Neutron imaging has been recognized as one of the powerful tools for conducting nondestructive inspection of various materials. We proposed the idea of a superconducting neutron detector called a current-biased kinetic inductance detector (CB-KID) with a neutron conversion layer of 10B. The practical usefulness was tested with various test samples to prove (1) a good spatial linearity between the Gd-island size determined by neutron transmission images and that determined by SEM images over various different sizes, (2) the Bragg-edge observation in neutron transmission spectra applied to a very narrow areas of Fe sample, and (3) the different orientations of YbSn₃ crystals were successfully mapped in neutron transmission image by the analysis of observed Bragg-dip positions in the transmission spectra.

The operating conditions of CB-KID have been systematically optimized in view of improving the spatial resolution, the temporal resolution, and the detection efficiency. In this talk, we report on applying the energy-resolving neutron imaging to investigate major components of material by analyzing the neutron transmission spectra. Each neutron transmission spectrum gives us information about constituent materials and their textures, phases, and strains. Since each element of the material can be separated by using its particular neutron-transmission spectrum in our analyses, we can identify each substance of test samples (commercial screws and nuts). Note that an Energy Dispersive Spectroscopy (EDS) often fails to identify this because it is a surface-sensitive probe and does not reveal the components under the surface. We demonstrated that our superconducting neutron detector is applicable to reveal the transmission spectra from cold-neutron energies to higher neutron energies even up to a hundred keV. This feature is partly a consequence of a high sampling clock of 1ns while we would like to improve this specification much more.

We also succeeded in mapping the distribution of elements in a SnSm₃ compound using the strong neutron absorption in Samarium (Sm) and the nuclear resonance dips in Sm. We

demonstrated the merits of using CB-KID for neutron imaging. The CB-KID method could be useful for various purposes in material sciences through neutron spectroscopy in future.

*Keywords: Neutron detector, CB-KID, Energy resolving, Neutron transmission.

*References:

- [1] Ishida T, Yoshioka N, Narukami Y, Shishido H, Miyajima S, Fujimaki A, Miki S, Wang Z, Hidaka M 2014 Toward mega-pixel neutron imager using current-biased kinetic inductance detectors of Nb nanowires with ^{10}B converter, *J. Low Temp. Phys.* **176** 216
- [2] Vu T D, et al. 2021 Practical tests of neutron transmission imaging with a superconducting kinetic-inductance sensor *Nucl. Instrum. Meth. Phys. Res. A* **1006** 165411
- [3] Vu T D, et al. 2022 Narrow-area Bragg-edge transmission of iron samples using superconducting neutron sensor *J. Phys.: Conf. Ser.* **2323** 012028
- [4] Shishido H et al. 2023 Orientation mapping of YbSn 3 single crystals based on Bragg-dip analysis using a delay-line superconducting sensor *J Appl Crystallogr* **56** 1–6
- [5] Vu T D, et al. 2019 Temperature dependent characteristics of neutron signals from a current-biased Nb nanowire detector with ^{10}B converter *J. Phys.: Conf. Ser.* **1293** 012051
- [6] Vu T D, et al. 2020 Kinetic inductance neutron detector operated at near critical temperature *J. Phys.: Conf. Ser.* **1590** 012036
- [7] Kardjilov N, Manke I, Woracek R, Hilger A and Banhart J 2018 Advances in neutron imaging *Materials Today* **21** 652–72

Short- Biography

Full name: VU THE DANG, Ph.D.

Academic position: Doctor of engineering

Job's position: Kawamata Lab, Division of Quantum and Radiation Engineering, Osaka Metropolitan University, Osaka, Japan.



Contacts:

1. Research Areas:

- Superconducting Devices and their system.
- Vortex physics, Vector SQUID sensor.
- Nondestructive Technology using Neutron Transmission Image, Superconducting Neutron detector.

2. Education:

- April 2018-March 2021: Post doctoral fellowship in Japan Atomic Energy Agency, Ibaraki, Japan
- April 2015 – March 2018: Doctor course in Osaka Prefecture University, Osaka, Japan
- August 2008 to September 2010: Master Course in Ho Chi Minh City University of Education Technology, Ho Chi Minh, Viet Nam

Email: vuthedang@omu.ac.jp

Handphone:

(+81) 090-8163-7979

Website of personal:

<https://www.researchgate.net/profile/Thedang-Vu>

- September 2002 to August 2007: study Electrics and Electronics Engineering in in Ho Chi Minh City University of Education Technology, Ho Chi Minh, Viet Nam

3. Academic Activities:

Members of academic society (name of society, position, where, when)

-From 2015-now: member of the Physical Society of Japan.

Visiting researcher/professor (university/institute, where, when)

-April 2021 to now: Guest researcher of Japan Proton Accelerator Research Complex (J-PARC), Ibaraki, Japan

4. Research Achievements and Awards:

Research projects (2010-now): Chief of Project

[1]. April 2021-March 2023: Grants-in-Aid for Scientific Research Grant-in-Aid for Early-Career Scientists (21K14566)

[2]. April 2023 – March 2025: Grants-in-Aid for Scientific Research Grant-in-Aid for Early-Career Scientists (23K13690)

5. ISI/Scopus/SCIE Selected Publications (2010-Now):

[1]. Vu T D, *et al.*, 2021 Practical tests of neutron transmission imaging with a superconducting kinetic-inductance sensor Nucl Instrum Methods Phys Res A **1006** 165411.

[2] Vu T D, *et al.*, 2020 Homogeneity of neutron transmission imaging over a large sensitive area with a four-channel superconducting detector Supercond Sci Technol **34**

[3] Vu T D, *et al.*, 2019 SQUID microscopy for mapping vector magnetic fields Supercond Sci Technol **32**.

[4] The Dang Vu, *et al.*, 2018 “Confined vortices in *de facto* mesoscopic Mo₈₀Ge₂₀ disks with sector defects”, *Supercond. Sci. Technol.* **31** 125009.

[5]. The Dang Vu, *et al.*, 2018, “Scanning SQUID Microscopy for Sensing Vector Magnetic Field” IEEE Trans. Applied Supercond. **28** 1601105.



ORAL PRESENTATION (Code: S1-01-O)

Application of energy-resolving neutron imaging to major-component analyses of materials using four-channel superconducting detector

Doan Thi Thanh Nhan, Phan Le Hoang Sang Dao, Van Hoang, Nguyen Van Hoai Nam and Ho Van Doanh

Radiation Protection and Environment Department, Center for Nuclear Technologies, Ho Chi Minh City, Vietnam

Email: dttnhan92@hotmail.com

Abstract

The self-absorption effect is one of the factors to consider when estimating the counting efficiency for alpha radioactivity measurement. To precisely quantify the alpha concentration in the sample, a correction for the self-absorption effect must be calculated. As a consequence, efficiency must be determined with a reference sample as a function of sample thickness. The self-absorption coefficient for samples with non-zero thickness is modeled as a function of density in this study. The coefficient of the equation is derived from a weighted least squares fit to a collection of paired mass density and self-absorption factors. In this work, we utilize the exponential model to construct a self-absorption curve and use it to compute the activity of a sample of any mass.

According to research, if no adjustment is applied, the alpha radioactivity in the sample will rapidly drop as the reported mass density increases. Self-absorption curves as a function of mass density have been produced for measuring Alpha radioactivity, with a correlation coefficient larger than 0.99. When the observed sample thickness exceeds 10 mg.cm⁻², the count remains nearly constant, and the activity after adjustment becomes unstable.

ORAL PRESENTATION (Code: S1-02-O)

Strain Effect on the Anomalous Hall Conductivity of Fe bcc

Nguyen Bui Trung Kien, Ho Anh Phuc, Do Duc Cuong and Trinh Thi Ly

Faculty of Physics and Engineering Physics, University of Science, Ho Chi Minh City, Vietnam

Email: nguyenbuitrungkien28@gmail.com

Abstract

In this study, the effect of elastic biaxial strain on electronic structure and the anomalous Hall conductivity (AHC) of alpha-Fe has been systematically studied by using the combination of first principles calculation with the tight binding method through the Wannier function. We find that the AHC of unstrained Fe is $855 \Omega\text{-1cm}^{-1}$ showing very good agreement with the previous calculations and experiments [1-2].

It is found that applying strain in cubic bcc structure of alpha-Fe results in the reduction of crystal symmetry and gives the modification on the bands near Fermi level, which causes a significant change in the AHC of strained systems. The AHC of strained alpha-Fe shows the large enhancement with “M” shape behavior, where maximum AHC obtained is up to $1350 \Omega\text{-1cm}^{-1}$ (increases 58%) at $\pm 1\%$. The modification of AHC is found to be related to the change of Berry curvature contributed from the SOC induced degenerated states near Fermi level.

ORAL PRESENTATION (Code: S1-03-O)

Interpretation of logging while drilling (LWD) documentation at the gray well

East mine Cuu Long Basin.

Pham Nguyen Duy Phuong, Nguyen Thi Minh Thu and Tran Tan

Faculty of Geology, University of Science, Ho Chi Minh City, Vietnam

Email: phamnguyenduyphuong96@gmail.com

Abstract

Geological logging plays a crucial role in evaluating the wellbore environment, providing insights into the characteristics of rock formations and the evolving state of the wellbore. The application of Logging While Drilling (LWD) technology, a relatively recent development, has become widespread. LWD measures parameters such as resistivity, porosity, natural radioactivity, ultrasonic waves, wellbore temperature, density, formation pressure, and fluid mobility within the formation.

At the Gray Well in the East Mine of the Cuu Long Basin, after analysis, the effective porosity of formations ranges from moderate to quite good (9-16%). The effective porosity of hydrocarbon-bearing formations falls in the range of 12-14%, while formations with lower to moderate porosity (9-11%) exhibit lower hydrocarbon saturation, approximately below 45%. Results obtained through three different methods (Excel, PATS, and WM) align relatively well with each other, indicating that the section containing oil in the well is accurately identified, and the porosity values are quite consistent. Thus, it is possible to accurately determine which section of the well contains oil, enabling further research for more precise and reliable information about the reservoirs. By utilizing this method, it is possible to accurately identify the type of fluid present in the reservoir at this section. This information can be instrumental in making decisions regarding hydrocarbon extraction in these wells.

ORAL PRESENTATION (Code: S1-04-O)

Preliminary study on radon concentrations in the South Plain of Vietnam's groundwater aquifers. Concentrations of radon in Tien Giang province's groundwater aquifers

Doan Thi Thanh Nhan, Nguyen Pham Tuong Minh, Phan Le Hoang Sang,
Nguyen Van Hoai Nam and Dao Van Hoang

*Radiation Protection and Environment Department, Center for Nuclear Technologies,
Ho Chi Minh City, Vietnam
Email: dttnhan92@hotmail.com*

Abstract

Radon concentrations in the South Plain of Vietnam's groundwater were measured. At the Q602 station in Tien Giang province, groundwater samples were gathered from six existing aquifers via groundwater monitoring wells. The quantity of radon-222 activity in a water sample was estimated by detecting its short-lived decay products on the water sample using gamma-ray spectrometry.

The radon activity concentrations range from 24.97 Bq.l⁻¹ to 102.26 Bq.l⁻¹. Except for water samples collected from the Miocene aquifer, most water samples show radon concentrations below the World Health Organization (WHO) recommended guideline of 100 Bq.l⁻¹. Based on the graph illustrating the change in radon concentration as an effect of water sample depth, it is possible to hypothesize that the Pleistocene aquifer's radon concentration falls with depth. The radon concentration increases with depth in the Pliocene aquifer and approaches saturation when it reaches the Miocene aquifer. However, there is little evidence to validate this hypothesis, thus additional studies at related groundwater aquifers must be conducted to further comprehend the rules of radon distribution in aquifers and consider employing them in groundwater flow studies.

ORAL PRESENTATION (Code: S1-05-O)

Simulating Climate Impacts on Rice Agroecosystems in An Giang Province: Pests, Yield, and Resources

Nguyen Duc Anh, Huynh Thi Huyen Tran, Le Mai Anh, Tran Nguyen Ha Trang, Le Thi Xuan Lan and Vo Luong, Hong Phuoc

*Department of Oceanology, Meteorology and Hydrology, Faculty of Physics and Engineering
Physics University of Science, Ho Chi Minh City, Vietnam
Email: vlhphuoc@hcmus.edu.vn*

Abstract

Rice is a staple food crop in Vietnam, with a majority of production centered in the Mekong River Delta, especially in An Giang province. Ensuring sustainable rice cultivation under climate change requires an understanding of how projected shifts may impact rice agroecosystems. Simulation modeling provides important insights for forecasting climate change effects on key factors like pests, diseases, yield, evapotranspiration, and water requirements. The warning model of 90-100 day rice crop insect pests and diseases is programmed in FORTRAN based on rice growth stages, pest and disease species, and meteorological factors. Results show certain pests proliferate while others manifest only at specific stages. Climate change models predict decreased pest pressure but also reduced yields in Vietnam, indicating a need for adapted management strategies. Separate rice yield modeling using ORYZA2000 reveals stable autumn-winter harvests but rainfall-vulnerable winter-spring and summer-autumn yields. Emission scenarios also predict declining yields by mid-century in studied regions.

Modeling of evapotranspiration and water requirements with CROPWAT 8.0 demonstrates highest evapotranspiration in summer-autumn and greatest water needs in winter-spring. Climate change scenarios project increasing evapotranspiration and water requirements through 2099, threatening rice production. In summary, complex meteorological interactions influence rice pests, diseases, yield, evapotranspiration, and water requirements in An Giang province. Climate change models consistently predict challenges to rice cultivation from pests, yield reductions, and rising resource demands.

ORAL PRESENTATION (Code: S1-06-O)

The influence of water- based drilling mud and oil-based drilling mud on well logging in Nam Con Son Basin.

Huynh Tuan Ngo, Tran Thien Quy, Phan Thi Huyen Tran, Pham Nguyen Thuy Vy
and Duong Bao Minh

Faculty of Physics and Engineering Physics University of Science, Ho Chi Minh City, Vietnam
Email: httuan@hcmus.edu.vn

Abstract

The change of physical properties (such as mechanical properties of rock, the sediments deposited velocity) lead to the huge impact of stratigraphics and oil and gas system. The geology condition of Nam Con Son basin is very complex; geologists have to use different methods and new techniques which is based on scientific to make the exploration and production plan for the next stage of this sediment basin. Researching the impact of oil - based drilling mud and water - based drilling mud on Well Logging in Nam Con Son basin to clarify and compare the influence of water - based drilling mud and oil - based drilling mud. We compared their effects by evaluating the formation properties in Well Logging. To evaluate the influence of oil - based drilling mud and water-based drilling mud, the research considers the difference of physical properties and function between oil-based drilling mud and water - based drilling mud, which is showed in Well Logging methods (SP, Gamma - Ray log; Sonic; Well Diameter Measurement). Through analysing 4 wells data (2 wells with water-based drilling mud: HA and RB; 2 wells with oil-based drilling mud: RT and S), the result shows that the diameter of wells used water - based drilling mud is changed much more than the diameter of wells used oil-based drilling mud. Because the wells diameter is stable, Well Logging (Resistivity, Gamma, Density, Sonic) of wells, which are used oil - based drilling mud, has the accuracy higher than Well Logging of wells which are used the other type.

POSTER PRESENTATION (Code: S1-01-P)

Establishing geographical mapping based on SEISMIC data, evaluation of oil and gas potential of the H50 layer- Rong field, Block 06.1 - Nam Con Son Basin

Phan Thi Huyen Tran, HuynhTuan, Pham Nguyen Thuy Vy and Duong Bao Minh

Faculty of Geology, VNUHCM-University of Science, Ho Chi Minh City, Vietnam

Email: 20160005@student.hcmus.edu.vn

Abstract

Seismic methods have a very important role in the field of exploration and research the geological structure. Rong oil field is located in Southwest edge of Mang Cau lifting zone, Nam Con Son basin. It was formed by the activity of the fault system and tectonic inversion during the Miocene period, so that the geological structure of field has the form like fault and cubes. Faults have an extremely important role in forming the current geological structural of the field. Most of the faults, which divide Rong oil field into cubes, play the seal rock role. That means cubes separated by faults can be independent of each other. Based on the combination of geological methods and 3D seismic interpretation by using Petrel software, we could interpret the seismic intersection; Determine geological boundaries, from that building the isochronous map, the iso - depth contour map, the iso – thickness map of the H50 layer.

On the isochronous map shows that the depth of H50 layer is from -1825 meters to -2375 meters with the value of contour lines is 25 meters, deeper in the East, Southeast and gradually shallow in the West and Northwest of the research area. The structure of the H50 layer in the iso - depth contour map is fit with the isochronous map of this layer. In the depth ranges from -2100 meters to -3050 meters with the value of contour lines is 50 meters, the East and the Southeast is deeper than the West and the Northwest of the study area, which is similar to the isochronous map. And the total in - place oil reserve of the three structures H50 - A1, H50 - A2, H50 - A3 is 366.27 billion c.

POSTER PRESENTATION (Code: S1-02-P)

Combination of well logs and seismic stratigraphy analysis of facies and depositional environment of Kainozoic sedimentary formation, block 15-01/5, Cuu Long basin.

Nguyen Thi Minh Thu, Pham Nguyen Duy Phuong and Huynh Tan Tuan

Faculty of Geology, VNUHCM-University of Science, Ho Chi Minh City, Vietnam

Email: ntthuminh05@gmail.com

Abstract

The characteristics of sedimentary depositional environments are important factors in evaluating the potential reservoir capacity of sedimentary rocks. Block 15-01/5 in the Cuu Long Basin features a complex structural and depositional environment, necessitating in-depth research. To investigate the facies and depositional environment, the author integrated the interpretation of well log data with seismic and geological information to clarify certain contexts of Kainozoi sedimentary deposition in the study area.

Based on the analysis of seismic and geological data, along with the well log analysis of wells B-1X and B-2X in the Cuu Long Basin, Block 15-01/5, the Kainozoi sedimentary formation is identified to consist of several units ranging from Unit E to Unit BI, which can be classified into three types: continental, transitional, and shallow marine environments.

By employing the gamma-ray log analysis method, the author has discovered detailed information about the lithology, petrology, and depositional environments of the sedimentary units from BI to E. The combination of seismic and geological analysis, as well as well log interpretation, proves highly effective in delineating the facies and depositional environments and contributes to improving accuracy in assessing the hydrocarbon potential of the B formation.

POSTER PRESENTATION (Code: S1-03-P)

The analysis of the nucleon single -particle wavefunction in the radial Harmonic oscillator potential for 16O

Trinh Hoa Lang, Nguyen Tri Toan Phuc, Huynh Thi Yen Hong and Truong Huu Ngan Thy

*Faculty of Faculty of Physics and Engineering Physics, VNUHCM-University of Science,
Ho Chi Minh City, Vietnam
Email: thlang@hcmus.edu.vn*

Abstract

Single-particle wavefunctions of the radial harmonic oscillator (HO) potential are often used as basis functions in Hartree-Fock (HF) or Density Functional Theory (DFT) calculations for nuclear structures, scatterings, or reactions. However, these basis functions are the analytical solutions of the Schrödinger equation in the radial harmonic oscillator potential without spin-orbit and Coulomb potentials. Although these single-particle wavefunctions are quite useful for solving the problems above, there is a difference between the solution of the pure HO potential with and without other, more specific interaction potentials.

In this work, the differences between the single-particle wavefunction of the pure HO potential and the numerical solution of the Schrödinger equation adding spin-orbit and Coulomb interactions for the nucleons are preliminarily investigated for the nucleus 16O.

POSTER PRESENTATION (Code: S1-04-P)

Searching and measuring intermediate-mass black holes in stellar clusters with Extremely Large Telescope

Ngo Ngoc Hai and Nguyen Ngoc Truong

*Faculty of Physics and Engineering Physics, VNUHCM-University of Science,
Hochiminh City, Vietnam
Email: hai10hoalk@gmail.com*

Abstract

My research focuses on IMBHs in various star clusters, quantifying the occupation fraction of low-mass black holes, and understanding their co-evolution with host galaxies. By combining data from the Hubble Space Telescope with simulations from the Extremely Large Telescope (ELT) and HARMONI instrument, we aim to enhance our understanding of the mechanisms behind black hole seed formation, particularly for the lightest central black holes in star clusters. This research will advance our knowledge of these central black holes' physics.

POSTER PRESENTATION (Code: S1-05-P)

Optimization of Al-decorated nitride SERS substrate for DNA sensing

Tran Thuy Quy Hien, Fan-Ching Chien and Kun-Yu Lai

*Email: tranthuyquyhien@gmail.com Department of Optics and Photonics,
National Central University, Taoyuan, Taiwan*

Abstract

Surface-enhanced Raman scattering (SERS) is one of the most powerful biosensors in light of its high specificity. Many SERS substrates employ Ag or Au for the metal nanostructure. However, Ag and Au are expensive, not to mention the instability of Ag. In this study, Al-decorated nitride SERS substrate was fabricated for DNA detection, which was expected for practical application. With proper selection of Al thickness and annealing condition, the Al-decorated SERS substrate can detect the 19-mer DNA at 1E-6 M.

POSTER PRESENTATION (Code: S1-06-P)

Investigating the radiation shielding properties of Iron oxide- Enhanced heavy concrete through Gamma transmission method

Le Hoang Minh, Dang Van Hau, Nguyen Duy Khai, Phan Nguyen Hoang Long, Tran Thi My Duyen, Nguyen Thi Truc Linh, Huynh Dinh Chuong and Tran Thien Thanh

Faculty of Physics and Engineering Physics, VNUHCM-University of Science, Hochiminh City, Vietnam

Email: hoangminh@hcmus.edu.vn

Abstract

This study investigates the radiation shielding properties of construction materials, with a focus on iron oxide (Fe₂O₃)-enhanced heavy concrete. It covers a range of Fe₂O₃ concentrations from 0% to 12.9% in concrete formulations and uses M200-grade standard samples as references. The study observes a linear increase in sample density as Fe₂O₃ content rises. A gamma transmission measurement system utilizing NaI(Tl) detectors assesses shielding effectiveness. It measures linear attenuation coefficients for concrete samples at 59.54 keV (²⁴¹Am), 661.7 keV (¹³⁷Cs), and 1332 keV (⁶⁰Co) energy levels.

Precise measurements result from careful calibration of detectors and radiation sources, ensuring a focused gamma ray beam. The findings establish a direct correlation between linear attenuation coefficients and Fe₂O₃ content at each energy level. Notably, samples with the highest Fe₂O₃ concentration exhibit significant increases in attenuation coefficients, such as 19.6% (59.54 keV), 7.75% (661.7 keV), and 13.5% (1332 keV), compared to standard samples. These insights suggest the potential use of iron oxide-enhanced heavy concrete as effective radiation shielding in construction applications.

POSTER PRESENTATION (Code: S1-07-P)

Analysis well logging interpretation, coring document, MDT-propose the drill-stem test of RD-X well, back oil field-block 15.1-Cuu Long Basin

Pham Nguyen Thuy Vy, Huynh Tuan, Phan Thi Huyen Tran and Duong Bao Minh

Faculty of Geology, VNUHCM-University of Science, Hochiminh City, Vietnam

Email: 20160033@student.hcmus.edu.vn

Abstract

Analysis, documents which are researched about Well logging play an important role on determining the reservoir, from that we can request accurately the depth and the location of drill-stem test. Black oil field is belonged to block 15-1, located in North- Northeast of Cuu Long basin, offshore of southern Vietnam. This structure has a large quantity of oil. Black oil field has the monoclinical structure which elongates northeast- southwest, this is a semi-graben. This place is developed by large structures which was inherited from pre-Tertiary arched granite basement rock and was covered by Oligocene sediments. That created the closed anticline and was limited by divergent faults (NE-SW).

Besides the main faults (NE-SW), there are other fault directions such as the East-West faults by the right-slip movement of the main fault; North Northeast-South Southwest faults, East-West faults, SW-NE faults inside the basement rock. Some main methods are utilized in the research: SP; Gamma- Ray log; Spectral Gamma log; Porosity logs; Resistivity logs; Conventional coring and sidewall coring; Modular Formation Dynamic Test. Based on the result of Well Logging Interpretation and documents of MDT, we could determine the range of depth is from 1767.2mMD to 1773mMD, the high porosity (32%), The average of Vsh is low (11.9%) and the saturation of oil is high, about 67.5% ($S_w=32.5\%$), which has great oil potential. In conclusion, oil-water boundary is about 1773mMD (1735.8 mTVDSS) in depth and 2490.8psi in pressure, so the drill-stem test is from 1767.2m/1729.4mTVDSS to 1771.7m/1733.9mTVDSS.

POSTER PRESENTATION (Code: S1-08-P)

Arrays of Au nanoparticles-decorated ZnO nanotubes as three-dimensional surface-enhanced Raman scattering substrates for detection of Cypermethrin pesticides

Nguyen Hoang Anh, Bui Thi My Anh, Nguyen Minh Chien, Le Hoai Trung, Le Van Ngoc and
Le Vu Tuan Hung

*Faculty of Physics and Engineering Physics, VNUHCM-University of Science,
Hochiminh City, Vietnam*

Email: ndkhanh@hcmus.edu.vn

Abstract

In this work, a highly sensitive three-dimensional SERS substrate based on gold nanoparticles-decorated zinc oxide nanotubes (Au/ZnO) has been developed for the detection of Cypermethrin pesticides. Arrays of ZnO nanorods were fabricated in advance by a hydrothermal method. Then ZnO nanotube arrays were achieved by immersing the arrays of ZnO nanorods in an aqueous solution of KCl for 8 h. Finally, gold nanoparticles were assembled onto the surface of ZnO nanotubes by simple photochemical method. A high density of gold nanoparticles attached to the fabricated ZnO nanotubes provides plenty of hotspots for Raman enhancement.

The surface morphology, crystalline structure, and optical absorption of the Au/ZnO heterostructure were examined by scanning electron microscopy (SEM), X-ray diffraction (XRD), and UV–Vis spectroscopy. Raman spectroscopy was used to evaluate the SERS performance of the Au/ZnO for Cypermethrin. The results show that the Au/ZnO substrate manifests high SERS sensitivity to Cypermethrin and a detection limit as low as 0.001 ppm. Therefore, the prepared Au-nanoparticles modified ZnO nanotube arrays have promising potentials to be applied to the rapid detection of pesticide residue traces on real samples.

PARALLEL SESSION

Session 2. Semiconductor Technologies, Materials, Device and Related

Chair: Prof. Le Vu Tuan Hung (VNUHCM-US, Vietnam);

Co-Chair: Prof. Kun Yu Lai (NCU-Taiwan) and Prof. Nguyen Hoang Nam (Hanoi VNU-University of Science, Vietnam)

Secretary: Nguyen Anh Thu

<i>Schedule</i>	<i>Speakers</i>	<i>Title of talks</i>	
14:00-14:20	Invited talk S2-01-I Prof. Le Vu Tuan Hung (VNUHCM-US, Vietnam)	Role of semiconductor and metal nanoparticles heterojunction in enhancing the SERS signal for detection the banned chemical trace in food, drug, and cosmetic.	42
14:20-14:40	Invited talk S2-02-I Dr. Nguyen Quang Khoi (VNUHCM-US, Vietnam)	Study of steady state thermal model for white LEDs thermal management application at encapsulant level	44
14:40-15:00	Invited talk S2-03-I Prof. Nguyen Hoang Nam (Hanoi VNU-University of Science, Vietnam)	Development of wound healing techniques using stem-cell spray gun and bio-nanomembranes	46
Coffee break (15:00-15:15)			
15:15-15:30	Oral S2-01-O Dr. Nguyen Van Men (AGU)	Plasmon properties in spin polarized double-layer graphene structures	46
15:30-15:45	Oral S2-02-O Dr. Nguyen Thi Thanh Van	Design and numerical analysis of an active Micro-T sinusoidal mixer with integrated microelectrode cavity.	49
15:45-16:00	Oral S2-03-O Dr. Do Duc Cuong	Large Enhancement of Intrinsic Spin Hall Conductivity of β -W Based Alloys	50
16:00-16:15	Oral S2-04-O Cu Duy Thanh (NCU- Taiwan)	High-Reflectivity Mo/Si Multilayer Mirrors for EUV Applications Fabricated by Ion Beam Sputtering	51
POSTER PRESENTATION: S2.01-P, S2.02-P, S2.03-P, S2.04-P, S2.05-P, S2.06-P.			52-55

INVITED TALK (Code: S2-01-I)

Role of semiconductor and metal nanoparticles heterojunction in enhancing the SERS signal for detection the banned chemical trace in food, drug, and cosmetic.

Le Vu Tuan Hung

*Faculty of Physics and Engineering Physics, VNUHCM-University of Science,
Hochiminh City, Vietnam
Email: lvthung@hcmus.edu.vn*

Abstract

In this work, the SERS substrate based on a combination of semiconductor and metal nanoparticles heterojunction for detection the banned chemical residues in food, drug or cosmetic is studied. The role of semiconductor for charge transfer in chemical mechanism (CM), metal nanoparticles for surface plasmon resonance in electromagnetic (EM) mechanism are thoroughly investigated. Semiconductors include ZnO nanorods, ZnO doped (AZO, IAZO), MoO_x... and nanoparticles include Ag and Au. The effect of adsorption between organic molecules and Ag nanoparticles in enhancing the SERS signal is also studied. The surface morphology, structure, and optical and electrical properties of SERS are investigated by scanning electron microscopy (SEM), Raman spectroscopy, ultraviolet-visible spectroscopy (UV-Vis), and Hall measurement. The results indicate that this heterojunction showed good behavior in crystallinity, highly effective surface area, and high conductivity. Furthermore, the Ag or Au NPs distribute uniformly on the SERS substrate and created good "hot-spots". The SERS substrate used to detect Rhodamine 6G (R6G) and molecules enhances strongly the Raman due to both EM and CM. The SERS substrate can detect R6G with a limit of detection (LOD) less than 10⁻¹⁰ M and molecules with a LOD less than 100 ppb.

*Keywords: SERS, nanoparticles, heterojunction, enhance Raman signal, EF, LOD

Short- Biography

Full name: Le Vu Tuan Hung, Associate Professor, Ph.D.

Academic position: Senior lecturer

Job's position: Department of Applied Physics, Physics & Engineering Physics Faculty, University of Science, National University of HCMC



Contacts:

Email address:

lvthung@hcmus.edu.vn.

1. Research Areas:

- Optics – Spectroscopy
- Nano materials
- Semiconductor - Photonics

2. Education:

(month/year to month/year, university/institute, country)

- Ph.D: 2007
- Master: 1998
- Bachelor/Engineer: 1994

3. Academic Activities:

Members of academic society (name of society, position, where, when)

- . Vietnam Physics Association
- . Vietnam Optics-Spectroscopy Association
- . Vietnam Association of Technical Physics

Academic supervisor for master/Ph.D thesis (name of title thesis, university/institute, where, when)

- . Supervisor of 58 masters from 2009
- . Supervisor of 3 PhD from 2012-2020
- . Supervisor of 3 PhD students now

4. Research Achievements and Awards:

Research projects (2010-now): Chief of Project

- . 1 project of University in 2004
- . 5 projects of National University of HCMC from 2005-2017
- . 1 project of State in 2022

Books

- [1]. 5 book for university program

5. ISI/Scopus/SCIE Selected Publication:

26 papers ISI/ SCIE (corresponding) from 2012

INVITED TALK (Code: S2-02-I)

Study of steady state thermal model for white LEDs thermal management application at encapsulant level

Nguyen Quang Khoi, Vo Thi Minh Ly, Huynh Van Tuan, Vu Thi Hanh Thu, Phan Nguyet Thuan, Hua Thi Hoang Yen, Nguyen Huynh Tuan Anh and Huynh Thanh Nhan.

*Faculty of Physics and Engineering Physics, VNUHCM-University of Science,
Hochiminh City, Vietnam
Email: lvthung@hcmus.edu.vn*

Abstract

Thermal management for white LEDs at encapsulant level is an important task for ensure for device can operates at a high optical and color performance. In this study, a steady state thermal model was built wherein the finite element method was employed using MATLAB software to identify the temperature distribution. Spatial temperature distribution of the encapsulant, blue LED die, and substrate region was easily simulated and predicted. The obtained results are not ony helpful in detecting the temperature behavior inside the packaging volume but also meaningful for designing the package configuration.

*Keywords: Thermal model, pcW-LEDs, thermal simulation using MATLAB, finite element method.

Short- Biography

Full name: QUANG-KHOI NGUYEN, Ph.D.

Academic position: Lecturer

Job's position: Faculty of Physics and Engineering Physics, University of Science-Vietnam National University Ho Chi Minh City, Vietnam.



Contacts:

Email: nqkhai@hcmus.edu.vn

Website of personal:

<https://phys.hcmus.edu.vn/vat-ly-tin-hoc/nhan-su/ts-nguyen-quang-khoi>

1. Research Areas

Advanced LED packaging technology

LED lighting

Optical properties of ZnO, TiO₂ for lighting application

Study of temperature distribution in LED (Simulation and experiment)

Modeling of the light source, luminescent material.

Design the emission spectrum for the light source

Technology of anti-blue light leakage for phosphor-converted white light emitting diodes (pc-WLEDs)

Quantum efficiency of the luminescent material (YAG:Ce; doped - YAGG phosphor)

Ultra Violet LED, Visible LED, and Near Infrared LED

2. Education

2022: Ph.D. in Optics and Photonics, National Central University, Taiwan

2015: Master of Science in Optics, VNUHCM-University of Science, Vietnam

2010: Bachelor in Physics, QuyNhon University, Vietnam.

3. Academic Activities:

Members of academic society: SPIE, OPTICA, and IEEE.

4. Research Achievements and Awards

5. ISI/Scopus/SCIE Selected Publications (selected)

1. *Quang-Khoi Nguyen*. "Emission spectrum modeling of white LEDs light source with using Gaussian function", *Photonics Letters of Poland* 15(4), 2023. (accepted)

2. *Quang-Khoi Nguyen*, and *Thi-Hanh-Thu Vu*. "An Efficient Method for Simulating the Temperature Distribution in Regions Containing YAG:Ce³⁺ Luminescence Composites of White LED" *Journal of Composites Science* 7, no. 7: 301. 2023.

3. *Quang-Khoi Nguyen*, *Benoit Glorieux*, *Gilles Sebe*, *Tsung-Hsun Yang*, *Yeh-Wei Yu* & *Ching-Cherng Sun*. "Passive anti-leakage of blue light for phosphor-converted white LEDs with crystal nanocellulose materials", *Scientific Reports* volume 13, Article number: 13039 (2022).

INVITED TALK (Code: S2-03-I)

Development of wound healing techniques using stem-cell spray gun and bio-nanomembranes.

Nguyen Hoang Nam, Hoang Thi My Nhung, Than Thi Trang Uyen, Luu Manh Quynh, Pham Van Thanh, Hoang Van Huy, Phi Thi Huong, Nguyen Tien Dat, Do Xuan Hai, Nguyen Hoang Luong, Bui Thanh Tung and Chu Duc Trinh

*Nano and Energy Center, VNU University of Science, Vietnam National University,
Hanoi, Vietnam*

Email: namnh@hus.edu.vn

Abstract

Wounds are a silent burden on the healthcare system. In 2018, Medicare beneficiaries analyzed that around 8.2 million people who have at least one type of wounds. Wounds often classified into acute (traumatic, abrasions, surgical) and chronic wounds (diabetic foot ulcers (DFUs), leg ulcers, and pressure ulcers) based on healing time. The challenges of healing wounds are the increase of infection, age and pathological background of the patient. Hence, the project aims to solve those problems with developing wound healing technique using stem-cell gun and bio-nanomembrane. A stem cells and stem cells derived products spraying gun will be developed using 3D printing technique. This gun will help the stem-cell products to be well distributed on the wound in order to heal faster and less infection.

In parallel, the bio nanomembranes created by a electrospinning device will be developed to create a nanoprotection layer for better wound healing. Besides, stem cell products, such as extracellular vesicles, will be used together with the other medium in order to induce the growth of skin cells at wounded site. The combination of those techniques, then, will be evaluated in vitro and will help the patients reduce the time of healing, less infection and less pain. The developed technique, especially, very useful to heal the broad wound of fire victims or burned soldiers and can be used widely in hospitals and emergency centers from local to central.

*Keywords: wound healing, 3D printing, stemcell, electrospinning, biomembrane.

Short- Biography

Full name: Nguyen Hoang Nam, Ph.D.

Academic title: Associate Professor, Senior lecturer

Institute: Nano and Energy Center, VNU University of Science, Vietnam National University, Hanoi, Vietnam



Contacts:

Email: namnh@hus.edu.vn

Handphone: (+84)-913-020286

1. Research Areas:

- Nanomaterials for life-science applications
- Magnetic nanoparticles
- Biosensor and microfluidic systems

2. Faculty/Department/Laboratory

- Nano and Energy Center
- Faculty of Physics
- Nanotechnology Master Program

3. Research Activities

1. Development of portable device for counting CD4⁺ T cells using nanoparticles and microfluidic system
2. Development of wound healing techniques using stem-cell spray gun and bio-nanomembranes
3. Application of MUSE cells in tubular tissue creation using scaffold-free based 3D bio-printing technology

4. Research Achievements and Awards

Books

- [1]. Nguyen Hoang Nam, Nguyen Hoang Luong, Chapter 7 - Nanoparticles: Synthesis and Applications. Materials for biomedical engineering: Inorganic Micro and Nanostructures, Elsevier 2019, ISBN 978-0-08-102814-8, pp 211-240
- [2]. Nguyen Hoang Nam, Chapter 3 – Multifunctional silver nanoparticles: Synthesis and applications. Silver micro-nanoparticles: Properties, Synthesis, Characterization, and Applications, IntechOpen 2021 ISBN 978-83968-660-3, pp. 47-60

5. ISI Selected Publications

- [1]. Nguyen Hoang Luong, Truong Thanh Trung, Tran Thi Hong, Nguyen Hoang Nam, Manh-Huong Phan, Péter Jenei, János L Lábár, Jenő Gubicza, Relating the magnetic coercivity to the L1₀ ordered FePd phase in annealed Fe_xPd_{100-x} nanoparticles, Applied Physics A 128 (10) (2022), 1-11.
- [2]. Ngoc Duc Vo, Anh Thi Van Nguyen, Hoi Le Thi, Nam Hoang Nguyen, Huong Thi Thu Pham, A Simple Approach for Counting CD4⁺ T Cells Based on a Combination of Magnetic Activated Cell Sorting and Automated Cell Counting Methods, Applied Sciences 11(21) (2021), 10.3390/app11219786
- [3]. An T. Pham, Dzung T. Tran, Linh H. Vu, Nang T. T. Chu, Nguyen Duy Thien, Nguyen H. Nam, Nguyen Thanh Binh, Luu T. Tai, Nguyen T. M. Hong, Nguyen Thanh Long, Duc H. Tran, Effects of TiO₂ nanoparticle addition on the flux pinning properties of the Bi_{1.6}Pb_{0.4}Sr₂Ca₂Cu₃O_{10+δ} ceramics, Ceramics International 48(14) (2022), 20996-21004

ORAL PRESENTATION (Code: S2-01-O)

Plasmon properties in spin polarized double-layer graphene structures

Dong Thi Kim Phuong; Nguyen Van Men

Dept. of Physics, VNUHCM-An Giang University, An Giang, Viet nam

Email: nvmen@agu.edu.vn

Abstract

We investigate plasmon properties in a double-layer graphene structure under the effects of an inplane external magnetic field within the random-phase approximation at zero temperature. Numerical calculations demonstrate that two plasmon modes exist in the system, corresponding to in-phase and out-of-phase oscillations of charges. The spin polarization P differently affects the optical and acoustic plasmon modes and their decay rate. As the spin polarization increases, the frequency of the acoustic mode decreases slightly while that of the optical mode increases significantly.

Besides, the existence of an external magnetic field expands the single-particle-excitation area of the system, therefore, plasmon modes become damped at a smaller wave vector, compared to those in the case of unpolarized systems. Finally, we found that the inhomogeneity of background dielectric decreases both the energy and decay rate of plasmon modes of the spin-polarized system.

ORAL PRESENTATION (Code: S2-02-O)

Design and numerical analysis of an active Micro-T sinusoidal mixer with integrated microelectrode cavity.

Nguyen Van Phu, Bui Van Anh, Pham Van Thanh, Luu Manh Quynh, Nguyen Hoang Nam, Nguyen Chung Tien, Nguyen Ngoc Quynh and Nguyen Thi Thanh Van

Vietnam Academy of Cryptography Techniques, Hanoi, Vietnam

Email: nguyenthithanhvancms@gmail.com

Abstract

This paper focuses on improving mixing efficiency through the design and investigation of a micromixer that utilizes a micro-T-sine geometry with a microelectrode cavity, employing numerical simulation. This work entails analyzing active mixers to enhance mixing efficiency by investigating the effects of microelectrode capacity, the placement of electrode pairs, the number of electrode pairs, and variations in voltage. The findings from the examinations indicate that the exceptional mixing efficiency of 85.7% is achieved through the utilization of the micro-T-sine structure featuring a microelectrode cavity. The integration of a microelectrode cavity into the fluidic structure substantially heightened mixing by generating robust turbulence. The use of numerous microelectrode cavities in the microchannel enhanced the performance of the micromixer, resulting in a reduction in mixing time. Furthermore, the research thoroughly investigated the quantity in the microchannel, uncovering that an optimal increase in a certain parameter enhances mixing efficiency. This proposal introduces a structure that holds promise for enhancing the mixing quality of micro-T-sine. Moreover, this study signifies remarkable progress, delivering enhanced efficiency at lowered costs for future applications.

ORAL PRESENTATION (Code: S2-03-O)

Large Enhancement of Intrinsic Spin Hall Conductivity of β -W Based Alloys

Nguyen Thi Thao Suong, Trinh Thi Ly and Do Duc Cuong

*Faculty of Physics and Engineering Physics, VNUHCM-University of Science,
Hochiminh City, Vietnam*

Email: ddcuong@hcmus.edu.vn

Abstract

Spin Hall effect (SHE) is the conversion of charge current to spin current. Non-magnetic heavy transition metals (TMs) are expected to have large spin Hall conductivity (SHC) thanks to their large spin-orbit coupling (SOC). Among transition metals, β -W with A15 structure, has been reported to be among the materials that have large SHC [1-3], and SHCs of its alloys are even much improved [2]. In this work, SHCs of β -W and its alloys with V and Ta have been theoretically studied by the combination of the first principles calculation with the tight binding method. Several compositions of Ta-W and V-W alloys are investigated. And for each composition, we consider all possible configurations, from that the relative energetics between the configurations are calculated to estimate the thermodynamic average of SHCs. Due to the same valence electrons of Ta and V, the band structures of Ta-W and V-W in the same configuration are quite similar resulting in a similar trend of SHCs. However, different energetics may result in the difference in the thermodynamic average of SHCs. We find that V is more favorable than Ta to alloy with β -W. The thermodynamic average of SHCs of W-V alloy enhances up to $-1208 \hbar/e$ S/cm, about 48% larger than $-817 \hbar/e$ S/cm of β -W at concentration of V is 25%, while that of Ta-W alloy decreases with Ta concentration.

ORAL PRESENTATION (Code: S2-04-O)

High-Reflectivity Mo/Si Multilayer Mirrors for EUV Applications Fabricated by Ion Beam Sputtering

Cu Duy Thanh, Guan-Jie Huang, Chien-Cheng Kuo

*Faculty of Physics and Engineering Physics, VNUHCM-University of Science,
Hochiminh City, Vietnam*

Email: cuduythanh0309@gmail.com

Abstract

The reflectance of extreme ultraviolet (EUV) light from multilayer mirrors is essential for improving the throughput of EUV lithography. However, molybdenum (Mo) and silicon (Si), the materials used to make EUV multilayer mirrors, tend to mix together and diffuse, which reduces the EUV reflectance below the theoretical maximum. This study investigated the use of ion beam sputter deposition to fabricate Mo/Si multilayers and to identify the ion beam parameters that resulted in the lowest degree of interface diffusion. The results showed that adding boron carbide (B₄C) layers at both interfaces reduced the interface diffusion thickness for almost all multilayers. Atomic force microscopy (AFM) results revealed that all multilayers had an average surface roughness below 0.1 nanometers, which indicates minimal scattering during EUV irradiation and the potential for higher EUV reflectance. The EUV reflectance of the multilayer was measured to be 40% at a 34-degree incident angle and a 13.5nm wavelength.

POSTER PRESENTATION (Code: S2-01-P)

An optical model for LEDs-based white light spectrum design with high color performance

Nguyen Trung Kien, Nguyen Thi Hanh, Pham Thi Yen Nhi, Huynh Thien Bao, Tran Le Minh Khang, Pham Dang Khoa, Nguyen Quoc Cuong and Nguyen Quang Khoi.

*Faculty of Physics and Engineering Physics, VNUHCM-University of Science,
Hochiminh City, Vietnam
Email: nqkhai@hcmus.edu.vn*

Abstract

We have developed an efficient optical model for simulating the white light spectrum design with high color performance. The model is applied to study the effect of green light on efficiency, and the effect of red on the CRI index. The obtained result is helpful for the solid-state lighting application to fabricate a light source that can emit white light with high color performance.

POSTER PRESENTATION (Code: S2-02-P)

Gold and silver nano-modified TiO₂ thin films: Research and Application of Photocatalysis and SERS

Bui Thanh Nguyen, Nguyen Tran Gia Bao, Ton Nu Quynh Trang and Vu Thi Hanh Thu
*Faculty of Physics and Engineering Physics, VNUHCM-University of Science,
Hochiminh City, Vietnam
Email: 22c32003@student.hcmus.edu.vn*

Abstract

In this study, we investigated and fabricated semiconductor TiO₂-based materials combined with Au and Ag nanoparticles. The synthesized material was assessed for its crystalline structure, morphological characteristics, and optical properties using SEM, TEM, and UV-Vis techniques. The results revealed that this material exhibits excellent detection efficacy at low concentrations of Crystal Violet (CV) solutions and degradation of Methylene Blue (MB) dye molecules. Specifically, CV was identified at a concentration of 10⁻⁷ M, and the degradation efficiency was approximately 96% under visible light irradiation for 120 minutes. This can be attributed to the synergistic effect of the surface plasmon resonance of Au and Ag, contributing to the enhancement of the electric field mechanism in SERS efficiency and improved light absorption in the visible light range. These results represent a significant advancement in the practical application of photocatalysis and SERS

POSTER PRESENTATION (Code: S2-03-P)

Impact of Al_xGa_{1-x}O Layer on Al_xGa_{1-x}O/Ga₂O₃ Field Effect Transistors: A TCAD Study

Nguyen Khanh, Do Huy Binh, Le Hoang Minh, Tran Thi Thanh Van,
De Souza and Maria Merlyne

*Faculty of Materials Science and Technology, University of Science,
Ho Chi Minh City, Viet Nam*

Email:

Abstract

Ga₂O₃, with an ultra-wide bandgap of ~ 4.6 eV, is a promising material for the next generation of high-power devices due to its high breakdown field of 8 MV/cm. Recently, a two-dimensional electron gas (2DEG) formed at the Al_xGa_{1-x}O/Ga₂O₃ interface has been reported, facilitating the fabrication of a high electron mobility transistor leveraging the advantage of the 2DEG layer. A novel Al_xGa_{1-x}O/Ga₂O₃ modulation-doped field-effect transistor (MODFET) is investigated in the Technology Computer-Aided Design (TCAD) study. The simulation device and experimental device are calibrated to ensure an alignment between them. The effects of AlGaO thickness and the delta doping concentration in AlGaO layer on the electrical properties of the MODFET are investigated. The results show that threshold voltage shifts to a negative direction when the delta doping concentration increases. The concentration of two-dimension electron gas (2DEG) strongly depends on delta doping concentration, leading to a significant change in the current-voltage characteristics of the Al_xGa_{1-x}O/Ga₂O₃ MODFET.

POSTER PRESENTATION (Code: S2-04-P)

SrTiO₃/g-C₃N₄/Ag Heteronanostructure for highly enhanced photocatalytic activity - MB detection

Pham The Phuong, Nguyen Tran Gia Bao, Ton Nu Quynh Trang and Vu Thi Hanh Thu
Faculty of Physics and Engineering Physics, VNUHCM-University of Science,

Hochiminh City, Vietnam

Email: 22C32006@student.hcmus.edu.vn

Abstract

Organic pollutants in wastewater have attracted much attention due to their potential to affect the environment and human health. In this study, the heterostructured SrTiO₃/g-C₃N₄/Ag (SCA) sample was fabricated by combining hydrothermal, calcination, and solution chemistry methods. After fabrication, the obtained samples were evaluated for their morphology,

crystallinity, and optical properties through SEM, TEM, EDX, and UV-Vis analyses. Additionally, the capability of detecting Methylene Blue (MB) at low concentrations and the degradation efficacy under visible light irradiation were assessed. The results show that the SCA specimen can detect the organic dye MB at a concentration of 10^{-6} M, and its decomposition efficiency reaches nearly 95% after 70 minutes of irradiation, compared to pure samples. This can be explained by i) the synergistic effect between SrTiO₃ (STO), g-C₃N₄ (gCN), and Ag; ii) the surface plasmon effect of Ag nanoparticles in the visible light region. Therefore, it contributes to improving the efficiency of electron transport and enhancing absorption in the visible light region.

POSTER PRESENTATION (Code: S2-05-P)

Effect of chemical bonding between organic molecules and Ag nanoparticles in enhancing SERS signal of Cu/Ag substrate to detect the food coloring

Nguyen Hoang Long, Nguyen Thi Ngoc Hang, Nguyen Duy Khanh, Dao Anh Tuan and Le Vu Tuan Hung

*Faculty of Physics and Engineering Physics, VNUHCM-University of Science,
Hochiminh City, Vietnam
Email: nhlong@hcmus.edu.vn*

Abstract

In this study, a copper metal substrate in the form of concave hemispheres combined with Ag nanoparticles was fabricated to detect SERS signals of food coloring such as Rhodamine 6G (R6G), Sunset Yellow (SY) and Fast Green FCF (FGF). Ag nanoparticles were fabricated by microwave heating. The morphology, structure, and optical properties of Ag nanoparticles were analyzed by SEM, DLS and UV-Vis methods. The fabricated substrate showed excellent SERS amplification, with the limit of detection (LOD) for R6G, SY and FGF are 10^{-8} ppm, 10^{-5} ppm and 10^{-3} ppm, respectively. Effect of the molecular structure of the analytes on the ability to increase SERS enhancement has also been studied through Langmuir and Freundlich adsorption models. The results show that there are differences in the adsorption properties of R6G, SY and FGF on the surface of Ag nanoparticles, demonstrating that the molecular structure of different substances has a great influence on the CM enhancement mechanism in the SERS measurement.

POSTER PRESENTATION (Code: S2-06-P)

Collective excitations in 4-BLG: Inhomogeneity effects

Vu Dong Duong

*Faculty of Physics and Engineering Physics, VNUHCM-University of Science,
Hochiminh City, Vietnam*

Email: vudongduong10@gmail.com

Abstract

We investigate the plasmon properties of a 4-BLG structure on an inhomogeneous background dielectric within the random-phase approximation. We obtain plasmonic excitations in layered structures can be found from the zeroes of the frequency-dependent dielectric function (ω denotes the frequency of collective excitations at a given wave vector \mathbf{k} while γ denotes the decay rate of plasma oscillations) and then calculate respective broadening functions. Computations demonstrate that there are four solutions to the zero point equation of the dynamical dielectric function, corresponding to four phases of collective excitations in the system. Three of them, acoustical modes, are lower than that in BLG at the same parameters while the optical mode has a higher frequency at a given wave vector. Secondly, we present that both the inhomogeneity of background dielectric and the inter-layer separation strongly decrease the plasmonic frequency and respective broadening functions.

Moreover, the inhomogeneity of the environment strengthens the effects of separation on plasmon properties. Lastly, the increase in doping density in BLG layers decreases strongly both plasmon frequency and its broadening functions. We observe that due to the pronounced contributions to plasmon properties of 4-BLG systems of the inhomogeneity, this factor should not be neglected in calculations

PARALLEL SESSION

Session 3. MEMS, Biosensors and Application

Chair: Prof. Nguyen Van Toan (Tohoku Univ, Japan);

Co-Chair: Prof. Nguyen Van Hieu (VNUHCM, Vietnam);

Secretary: Nguyen Hoang Quan-MSc

<i>Schedule</i>	<i>Speakers</i>	<i>Title of talks</i>	
14:00-14:20	Invited talk S3-01-I Prof. Nguyen Van Hieu (VNUHCM, Vietnam)	Using ML for determine the optimal size of the heat sink for high performance of Thermoelectric generators (TEGs) in the Aquaponic farm.	57
14:20-14:40	Invited talk S3-02-I Prof. Nguyen Van Toan (Tohoku Univ.-Japan)	Nanoengineered micro-supercapacitors for self-powered wireless sensing systems	60
14:40-15:00	Invited talk S3-03-I Dr. Hitoshi Nishino (Tamagawa Holdings Co., Japan)	A high-precision 3-dimensional micro-mirror actuated by piezo-actuators	64
Coffee break (15:00-15:15)			
15:15-15:30	Oral S3-01-O (online) Dr. Sura Nguyen (THSM, Mexico)	Characterizing joule heating effects on carbon nanofibers: Calculating the temperature coefficient of resistance for precise nanostructure growth control	66
15:30-15:45	Oral S3-02-O Zhijian Zhao (Japan)	High-sensitivity magnetic field sensor using magnetic torque	67
15:45-16:00	Oral S3-03-O Yi-Hsiu KAO (Japan)	Enzyme-based Chemiresistive Creatinine Biosensor	68
16:00-16:15	Oral S3-04-O Nguyen Hoang Quan	TEG-self-powered system for wireless sensing node in Aqua-green-house	69
16:15-16:30	Oral S3-05-O Dr. Tran Ngoc Dang Khoa (IUH)	A novel design for a MEMS shock sensor with two thresholds.	70

POSTER PRESENTATION: S3.01-P, S3.02-P, S3.03-P.

71-72

INVITED TALK (Code: S3-01-I)

Using ML for determine the optimal size of the heat sink for high performance of Thermoelectric generators (TEGs) in the Aquaponic farm.

Nguyen Van Hieu, Mai Thanh Tan Cuong, Nguyen Phan Minh Nguyet, Bui The Anh, Nguyen Hoang Quan and Vu Do Huy Cuong

Department of Physics and Electronic Engineering, Faculty of Physics and Engineering Physics; Department of Mechanics, Faculty of Mathematics and Computer Sciences, VNUHCM-University of Science, Vietnam

Email: nvhieu@hcmus.edu.vn

Abstract

Here, the TEG device consists of 18 pairs with their dimensions of $1.3 \text{ mm} \times 1.3 \text{ mm} \times 1.5 \text{ mm}$ and its Si substrate of $40 \text{ mm} \times 40 \text{ mm}$ are the input data for using COMSOL to determine the dimensions of heat sink with Al for the maximum output powers, high efficiency of the TEGs for the applying IoT sensors system in Aquaponic farm.

The output powers of this TEG can reached the maximum of power is 3564,60mW at temperature difference ΔT of $13.7 \text{ }^\circ\text{C}$ and the maximum of 63,77mW when its temperature difference ΔT is $0.8 \text{ }^\circ\text{C}$. However, at temperature difference of $5.4 \text{ }^\circ\text{C}$, the out put power also get high value of 502 mW. Therefore, the bigger dimensions of TEG is the higher out put power. Machine Learning (ML) can support to find out with high accuracy the best size of the heat sink for maximum power generation capacity and high efficiency of Thermoelectric generators (TEGs) in the Aquaponic farm. It will be a new method that helps determine quickly and accurately the surveying power of TEGs.

*Keywords: Thermoelectric generator, Out put power, DC-DC boost, Power mangement circuit, Machine Learning (ML), Aquaponic system.

*References:

- [1] Chang S-Y, Cheng P, Li G, Yang Y. Transparent polymer photovoltaics for solar energy harvesting and beyond. *Joule* 2018;2(6):1039–54.
- [2] Toan NV, Hasana MMIM, Udagawa D, Inomata N, Toda M, Said SM, et al. Thermoelectric generator battery using 10 nm diameter of Al₂O₃ nanochannels for low-grade waste heat energy harvesting. *Energy Convers Manage* 2019;199:111979.
- [3] Zhang Y, Phuong PTT, Roake E, Khanbareh H, Wang Y, Dunn S, et al. Thermal energy harvesting using pyroelectric-electrochemical coupling in ferroelectric materials. *Joule* 2020;4(2):301–9.
- [4]. Nguyen Van Toan, Truong Thi Kim Tuoi, Nguyen Van Hieu and Takahito Ono. ThermoElectroc Generator with a high integration density for portable and wearable self-powered electronic devices. *Energy Conversion and Management* 245 (2021) 114575.

Short- Biography

Full name: Nguyen Van HIEU, Associate Professor, Ph.D.

Academic position: Senior lecturer

Job's position: Deputy Director, Department of Science and Technology, Vietnam National University HoChiMinh city (VNUHCM), Vietnam.

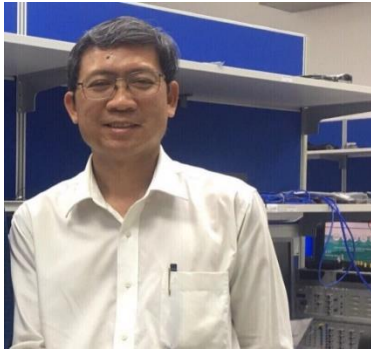

Contacts:

Email: nvhieu@hcmus.edu.vn.

Handphone: (+84) 903.629704

Website:

<https://en.hcmus.edu.vn/>

1. Research Areas

- MEMS, Biosensors and LEDs, UVLEDs
- Digital MicroFluidics for Biomedical Applications
- Electronic Engineering Circuits (Equipments, IoT,...)

2. Academic Unit

- Current: Inviting Researcher, Lab of Biosensors and Electronic Engineering (BiEE Lab);
- 2007- Oct. 2022:
Dept. of Physics and Electronic Engineering
Faculty of Physics and Engineering Physics
University of Science, VNUHCM.

3. Academic Activities

- Visiting senior lecturer
- Member: the Physics Society of Vietnam, the editorial board of the Journal of the Korean Institution of Electrical and Electronic Engineers (IKEEE), Institute of Electrical Engineers of Japan (IEEJ).
- International research works: Inviting researcher (Ritsumeikan Univ, Jp), research professor (Sophia Univ, Jp), co-Principal investigator (2021-2023, NCHU-Taiwan).
- Invited talks: ASPA2013 (in SHTP), 4S international Conference 2010, 2012, SHTP Annual Conference 2014, STT41 (Thailand), SHTP Annual Conference 2016, MRS (Thailand 2017), IKEEE conference (2017, 2018), 7th&8th Benjamitra Conference (2016, 2018, Thailand), ODF20, ISET2021, 2023, OPTIC2022-2023 (Taiwan),...
- Publications: over 50 international, domestic papers and 30 proceeding in workshop, conferences;
- Educations: lecturer for 3 subjects, scientific supervisors more than 50 bachelors, master and PhD students.

4. Research Achievements and Awards

Research projects (2005-2018): 05 Chief of Project
Intellectual Property

[1]. Nguyen Van Hieu, Ngo Vo Ke Thanh and Nguyen Ngoc Dao: IP certificate: *Cấu trúc “kép” đa giếng lượng tử MQW cho phát xạ cực tím*. No. 81529/QĐ-SHTT (MOST, Vietnam, 2016).

Books

[1]. Nguyen Van Hieu, book for study, *MicroElectroMechanicalSystem: Design and Simulation* (in Vietnamese), VNUHCM Publisher House (320 pages, Apr., 2011).

[2]. Nguyen Van Hieu and Nguyen Dac Hien, book for study, Electrical Safety Engineering in Industrial (in Vietnamese), VNUHCM Publisher House (290 pages, June, 2011) (ISBN: 978-604-73-0607-7).

[3]. Nguyen Van Hieu, Book for study: Electronic Circuits and Their Applications VNUHCM Publisher House (250 pages, Dec, 2015) (ISBN: 978-604-73-3739-2).

Research Awards :07

5. ISI Selected Publications (2014-now)

[1]. Yo Sheng Lin, Guo Hao Li and Nguyen Van Hieu: A 75–85GHZ Down-conversion mixer with intergrated marchand baluns in 90 nm CMOS with excellent matching and port-to-port isolation for automotive radars, **Microwave and Optical Technology Letters**, Vol. 57, No. 1,73-80 (SCI);

[2]. Congo Tak-Shing Ching, Teng-Yun Cheng, Nguyen Van Hieu and Lin-Shien Fu: *Liver Cancer Detection by a Simple, Inexpensive and Effective Immunosensor with Zinc Oxide Nanoparticles*, **Sensors 2015**; 15: 29408–29418 (SCI)(2015) (Q2-SCImago/Scopus);

[3]. Wen-Chi Yang, Su-Yu Liao, Thien Luan Phan, Nguyen Van Hieu, Pei-Yi Chu, Chin-Chang Yi, Hsing-Ju Wu, Kang-Ming Chang, Congo Tak-Shing Ching: *An Immunosensor for the Detection of ULBP2 Biomarker*. **Micromachines 2020**; 11: 568 (Q2-SCImago/Scopus);

[4]. Thien Luan Phan, Nguyen Van Hieu, Tzong Shiun Li, Ko-Chang Tsao, Congo Tak Shing Ching: *Noninvasive and real-time in vivo characterization of Inflammation skin*. **Skin Research and Technology 2021**; 00: 1-8 (Q2-SCImago/Scopus);

[5]. Yi-Tai Chen, Nguyen Van Hieu, Thien Luan Phan, Tzong Shiun Li, Siang-Ru Chen, Congo Tak Shing Ching: *A Dynamic Joint Angle Measurement Device for an Active Hand Rehabilitation System*. **Journal of Healthcare Engineering 2021**; 2021: 6688345 (Q3-SCImago/Scopus);

[8]. Nguyen Van Toan, Truong Thi Kim Tuoi, Nguyen Van Hieu and Takahito Ono: *ThermoElectroc Generator with a high integration density for portable and wearable self-powered electronic devices*, **Energy Conversion and Management 245** (2021) 114575 (Q1-SCImago/Scopus).

[6]. Do Thi Vien Thao, Wei-Tzu Weng, Nguyen Van Hieu, Cheng-Chung Chang, GouJen Wang: “A flexible and stretchable photonic crystal film with sensitive structural color-changing properties for spoiled milk detection”, **Food Chemistry: X 16** (2022) 100526.

[7]. Minh-Khue Ha, Thien Luan Phan, Duc Hoang Ha Nguyen, Nguyen Hoang Quan, Ngoc Quan Ha Phan, Congo Tak Shing Ching and Nguyen Van Hieu: “Comparative Analysis of Audio Processing Techniques on Doppler Radar Signature of Human Walking Motion using CNN Models”. **Sensors 2023**, 23, x (accepted). <https://doi.org/10.3390/xxxxx>

INVITED TALK (Code: S3-02-I)

Nanoengineered micro-supercapacitors for self-powered wireless sensing systems

Nguyen Van Toan, Truong Thi Kim Tuoi, Nguyen Van Hieu and Takahito Ono

Ono / Toda Laboratory, Graduate School of Engineering, Tohoku University, Sendai, Japan

Email: nguyen.van.toan.c6@tohoku.ac.jp

Abstract

This work presents a comprehensive investigation of micro-supercapacitors (MSCs) based on graphene nanowalls (GNWs), covering core material synthesis, device fabrication, evaluation, and application demonstrations. Three-dimensional hierarchical GNWs structures are grown successfully by a microwave plasma-enhanced chemical vapor deposition (MPECVD), with detailed descriptions of the synthesis process and underlying mechanisms. The structural and morphological properties of the GNWs are thoroughly analyzed. Several types of MSCs are reported, ranging from thin-film to three-dimensional (3D) MSCs, as well as symmetric to asymmetric MSCs. Thin-film MSC is developed by a novel micromachining process for one-step fabricating GNWs-Ni core-shell composite microstructures. A solid-state MSC utilizing 3D hierarchical electrode is created by a fully micro electro mechanical system (MEMS)-compatible process. This involves depositing GNWs-RuO_x hybrid nanostructures onto microstructure scaffolds formed using deep reactive ion etching (deep RIE). Additionally, another 3D MSC utilizes GNWs-PANI electrode material deposited on silicon nanowires generated through metal-assisted chemical etching (MACE) method.

To enhance MSCs performance, asymmetric MSC is proposed and realized, incorporating GNWs-MnO₂ acting as the positive electrode and carbon black serving as the negative electrode. Furthermore, the successfully combination of the fabricated MSCs with an energy harvesting system is demonstrated. The self-powered sensing system driven by solar energy, with the harvested energy stored in MSCs, is effectively showcased, opening up new possibilities for futuristic MSCs to accumulate and store harvested energy as usable electricity. This

The 4th International Conference on Engineering Physics, MEMS-Biosensors and Applications (ICEBA2023)

VNUHCM-University of Science, December 8-9, 2023

Venue: 227 Nguyen Van Cu Street, District 5, Ho Chi Minh City, Vietnam

demonstration has significant potential in fields such as self-powered wireless IoT sensing systems, offering valuable contributions towards sustainable and autonomous energy solutions.

*Keywords: Micro-supercapacitor, graphene nanowalls, metal oxide, deep reactive ion etching, metal-assisted chemical etching.

Short- Biography

Full name: Nguyen Van Toan, Associate Professor, Dr. Eng.

Academic position: Associate Professor

Job's position: Department of Mechanical System Engineering, Graduate School of Engineering, Tohoku University



1. Research Areas :

- MEMS/NEMS
- Energy harvesters
- Energy materials
- Nanomaterials

2. Education:

- Master of Science: 2009, University of Science, Ho Chi Minh City, Vietnam.
- Dr.Eng: 2014, Tohoku University, Japan

3. Academic Activities:

Members of academic society (name of society, position, where, when)

- Nanomaterials, Guest editor, special issue: Micro-Nanoengineering systems
- Frontiers of energy, Associate editor

Contacts:

Email address:

nguyen.van.toan.c6@Tohoku.ac.jp

Handphone: (+81)90-6457-5806

Website of personal/ lab/dept:
https://www.nme.mech.tohoku.ac.jp/index_e.html

Invited talks for International conference/workshop

Nguyen Van Toan, Truong Thi Kim Tuoi and Takahito Ono, “Heat storage thermoelectric generators for IoT sensing applications”, *Vietnam summit in Japan 2019*, Tokyo, Japan, November 16, 2019.

Nguyen Van Toan, Truong Thi Kim Tuoi and Takahito Ono, “Self-powered wireless BLE sensing system driven by low-temperature waste heat”, *The 7th Southeast Asia Conference on Thermoelectrics (SACT2022 hybrid conference)*, December 7-8, 2022, Sakon Nakhon, Thailand.

(Peer-reviewed Paper, total 69 papers)

Nguyen Van Toan, Truong Thi Kim Tuoi, Naoki Inomata, Megat Muhammad Ikhsan Megat Hasnan, Masaya Toda, Ioana Voiculescu, Suhana Mohd Said, and Takahito Ono, “Nanoengineered nanochannels for thermally ionic nanofluidic energy harvesting”, *Energy conversion and management*, **264**, 115760, 2022.

Nguyen Van Toan, Truong Thi Kim Tuoi, and Takahito Ono, “High-performance flexible thermoelectric generator for self-powered wireless BLE sensing systems”, *Journal of Power*

Sources, **536**, 231504, 2022.

Nguyen Van Toan, Truong Thi Kim Tuoi, Nguyen Van Hieu and Takahito Ono, “Thermoelectric generator with a high integration density for portable and wearable self-powered electronic device”, *Energy conversion and management*, **245**, 114571, 2021.

4. Research Achievements and Awards:

He has received many awards, including Electrical Science Promotion award from IEEJ (2022), Young research award from the 78th ubiquitous computing system research conference (2023), 100 outstanding Vietnamese peoples in Japan from Embassy of the Socialist Republic of Vietnam in Japan.

INVITED TALK (Code: S3-03-I)

A high-precision 3-dimensional micro-mirror actuated by piezo-actuators

Hitoshi Nishino and Takahito Ono

*Ono / Toda Laboratory, Graduate School of Engineering, Tohoku University, Sendai, Japan
And Tamagawa Holdings Co., Japan*

Email: nishino-hitoshi@tmex.co.jp

Abstract

Recently, there has been an increased demand for high-speed and high-capacity satellite communication. In this work, a high-precision 3-dimensional micro-mirror as an optical control device suitable for space optical communication is proposed, designed, fabricated, and evaluated. The mirror is driven by 8 bulk piezo-actuators, and mirror angles can be precisely controlled. This is suitable for communication over a distance of 1000 km, with the mirror angle controlled to a micro-degree order. For design, the method of matrix calculations is used in the control system to tune the mirror angle and position, and simultaneously to trace optical light for communication. For fabrication, a glass substrate is processed, and 2×2×2 mm bulk piezo-actuators are assembled for the drive system. The measurement result shows the character of the device to control the optical light using each actuator, whose maximum displacement is – 2.2 μm at 100 V. The measurement results are compared with the calculated results, and it is shown that both of results are similar. Lastly, it is concluded that the proposed high-precision 3-dimensional micro-mirror and design method can be applied to space optical communication.

*Keywords: micro actuator, 6-DOF, assembly, micro mirror, bulk piezoelectric device.

Short- Biography

Full name: Hitoshi Nishino, Ph.D.

Job's position: Research Manager, Tamagawa Holdings Co., Ltd.

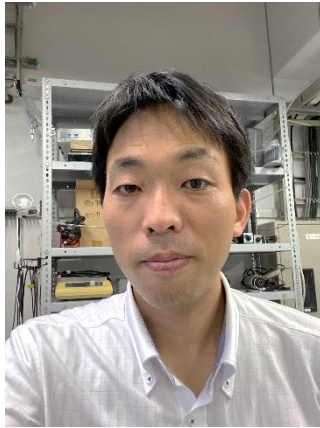

Contacts:

Email address:

nishino-hitoshi@tmex.co.jp

Handphone: (+81)3-6435-6933

Website of personal/ lab/dept:

<https://www.tmex.co.jp/en/>

1. Research Areas:

- MEMS
- Assembly
- Micro-optics

2. Education:

- Ph.D. in Mechanical Systems Engineering in 2019 from the Tohoku University in Japan.

3. Academic Activities:

Members of academic society (name of society, position, where, when)

- Member of IEEJ
- Member of APS

Invited talks for International conference/workshop

Hitoshi Nishino, "Reflection-typed miniature atomic clocks and micro-optical system", **International Congress and Expo on Optics, Photonics and Lasers & International Congress and Expo on Materials Science & Nanoscience**, Paris, France, June 28, 2023.

(Peer-reviewed Paper)

Hitoshi Nishino, Yasubumi Furuya, and Takahito Ono, "Micro-fabricated vapor cells with sealed Rb atoms by distillation at wafer level and two-step bonding for miniature atomic clocks," **Opt. Express** **29**, 44316-44321 (2021)

Hitoshi Nishino, Yuichiro Yano, Motoaki Hara, Masaya Toda, Masatoshi Kajita, Tetsuya Ido, and Takahito Ono, "Reflection-type vapor cell for micro atomic clocks using local anodic bonding of 45° mirrors," **Opt. Lett.** **46**, 2272-2275 (2021)

4. Research Achievements and Awards:

He has received the encouragement award in the 30th SENSOR SYMPOSIUM on Sensors, Micromachines and Application Systems Nov 2013 in Sendai, Japan, and nominated the encouragement award in the 38th SENSOR SYMPOSIUM on Sensors, Micromachines and Application Systems Nov 2021 in Himeji, Japan.

ORAL PRESENTATION (Code: S3-01-O)

Characterizing joule heating effects on carbon nanofibers: Calculating the temperature coefficient of resistance for precise nanostructure growth control

Arnoldo Salazar, Claudia B. Flores, Marc J. Madou, Nancy E. Ornelas, Alejandro Montesinos-Castellanos and Sergio O. Martínez

School of Engineering and Sciences, Institute of Technology and Higher Studies of Monterrey, Mexico

Email: a00831054@tec.mx, nguyensura@gmail.com

Abstract

Joule heating (JH) plays a pivotal role in nanotechnology, allowing precise control over nanoscale material properties and growth processes. This study explores the application of JH on carbon nanofibers (CNFs), investigating their role in facilitating the localized growth of carbon nanotubes (CNTs) on suspended CNFs. The electrical behavior of CNFs during JH is systematically analyzed, considering factors like lattice vibration, electron liberation, and lattice structure distortion. Through a thorough analysis of experimental data and establishing temperature thresholds for these phenomena, we calculate the temperature coefficient of resistance (α), enabling accurate real-time temperature control. Precision in temperature measurement on CNFs is crucial for reproducible JH experiments and growing specific nanostructures. This research also establishes a correlation between structural changes in CNFs and their electrical and physical characteristics during JH. The observation of stable resistance above 1800°C is connected to constraints in the transition from sp³ to sp² hybridizations. Furthermore, thermal expansion, driven by the creation of porous and graphitic structures at 2300°C, is investigated, with expansion parallel to the electrospun wire axis attributed to graphitic layer alignment. The study extends to localized chemical vapor deposition (CVD) of CNTs on CNFs, monitored by temperature, with Raman analysis confirming improved structural quality post-CVD. The resulting hybrid CNTs/CNFs exhibit impressive electrical conductivity (476 S.cm⁻¹), showcasing promising applications in biomedical engineering, health sciences, and smart cities

ORAL PRESENTATION (Code: S3-02-O)

High-sensitivity magnetic field sensor using magnetic torque

Zhijian Zhao, Masaya Toda and Takahito Ono

Ono / Toda Laboratory, Graduate School of Engineering, Tohoku University, Sendai, Japan

Email: zhao.zhijian.r8@dc.tohoku.ac.jp

Abstract

This paper reports a novel magnetic sensor consisting of a cantilevered resonator with a permalloy pillar and piezoresistive readout. Using AC magnetic field generated from an external coil, the pillar on the cantilever can be vibrated, and the magnetization of the permalloy pillar is modulated. The application of the external magnetic field induces a magnetic torque to the pillar and causes the shift of the resonant frequency. The magnetic sensor is fabricated and evaluated to be a maximum magnetic field sensitivity of 115 Hz/mT and a minimum sensing resolution of 25 nT in lab environment.

ORAL PRESENTATION (Code: S3-03-O)

Enzyme-based Chemiresistive Creatinine Biosensor

Yi-Hsiu Kao, Takahito Ono, Truong Thi Kim Tuoi, Nguyen Van Toan

Ono / Toda Laboratory, Graduate School of Engineering, Tohoku University, Sendai, Japan

Email: kao.yi-hsiu.r3@dc.tohoku.ac.jp

Abstract

There is an increasing demand for inexpensive, disposable sensors due to point-of-care testing and the pursuit of healthy living [1]. In this study, we target creatinine in the urine which concentration value is an essential biochemical substance used for correction in urinalysis. We proposed a novel enzyme-based chemiresistive biosensor to realize a portable and inexpensive way to measure creatinine at home. The proposed chemiresistive biosensor is shown in Fig. 1. Chemiresistive biosensors detect a biomarker based on the resistance change of resistor due to the change in the chemical environment [2]. Therefore, chemiresistor utilizes enzymes to create the chemical reaction. This leads to the conductivity change of the chemiresistor.

The DC voltage was applied to the chemiresistive biosensor to evaluate the change of the conductance, as shown in Fig. 2. Fig. 3 shows the results of the chemiresistive biosensor tested in creatinine solutions. The average of the two output current is plotted as a function of the creatinine concentration in Fig. 4, which shows an upward trend when the creatinine concentration increases. This result is consistent with the working principle, which is that the higher the creatinine concentration, the more chemical reaction occurs between the creatinine and the enzyme.

ORAL PRESENTATION (Code: S3-04-O)

TEG-self-powered system for wireless sensing node in Aqua-green-house

Nguyen Hoang Quan, Ho Thanh Huy, Nguyen Phan Minh Nguyet, Nguyen Van An, Nguyen Chi Nhan, Nguyen Van Toan and Nguyen Van Hieu

Faculty of Physics and Engineering Physics, VNUHCM-University of Science, Vietnam

Email: nhquan@hcmus.edu.vn

Abstract

This primary objective is to leverage surplus heat within the greenhouse environment as a valuable resource for generating electricity. Specifically, the aim is to harness this excess thermal energy to power IoT sensing systems, thus paving the way for more efficient and eco-friendly agricultural practices. To realize this aim, the proposal advocates the utilization of thermoelectric generators (TEGs), a cutting-edge technology capable of converting temperature differences into electrical energy. By strategically deploying TEGs within the greenhouse, the intention is to capture the temperature disparities between the internal environment and the circulating water, thereby creating a sustainable source of electricity.

The advancement of the wireless sensing system in agriculture is pivotal. It promises real-time data collection and monitoring capabilities, allowing farmers to make informed decisions based on environmental conditions. These sensors can measure factors like temperature, humidity, pH levels, and dissolved oxygen, providing essential insights for optimizing crop growth and fish cultivation in the Aquaponic green-house.

In this study, the JDY-23 BLE module is used as a signal transmission circuit to smartphone, and the SHTC3 temperature-humidity sensor collects temperature and humidity data of the internal environment in the green-house.

To enhance the ability of absorbing heat from the environment to the sides of the TEG, heatsinks are used to balance the temperature from the sides of the TEG as close to the ambient temperature as possible, thereby generating large amounts of energy than. This amount of energy from the millivolt range will be pushed to the volt range through a DC-DC boost circuit, and stored in the battery storage through the PMIC circuit. The battery storages are selected based on the energy consumption of the wireless sensor node circuit during the intermittent signal transmission through the IC wake-up timer to optimize the node's energy consumption.

These studies will lead the farmers to remotely monitor environmental conditions, receive alerts, and intervene by controlling these sensors through IoT technology.

ORAL PRESENTATION (Code: S3-05-O)

A novel design for a MEMS shock sensor with two thresholds

Tran Ngoc Dang Khoa and Nguyen Cong Son

Faculty of Mechanical Engineering, Industrial University of Ho Chi Minh City, Vietnam..

Email: tranngocdangkhoa@iuh.edu.vn

Abstract

The shock sensor provides protection to equipment during operation by detecting sudden speed changes. This article presents the design of a micro-level shock sensor that is able to detect acceleration values in two different threshold ranges. This structure includes a moving mechanism, a thermoelectric mechanism that restores the sensor, and capacitive sensing mechanisms that convert the displacement signal to an electrical signal. The sensor is based on a compliant multi-stable mechanism so that it will be able to operate with high precision and saving a large amount of energy. An investigation of the characteristics of moving mechanisms is conducted using finite element methods and numerical calculations. The influence of current and temperature on the displacement of the reset mechanism was also investigated. Two acceleration values of 13 g and 48 g are detected by an optimized shock sensor structure.

POSTER PRESENTATION (Code: S3-01-P)

IoT sensing systems driven by daily ambient temperature variations

Truong Thi Kim Tuoi, Nguyen Van Toan, Nguyen Van Hieu and Takahito Ono

Ono / Toda Laboratory, Graduate School of Engineering, Tohoku University, Sendai, Japan

Email: nguyen.tuoi.b6@tohoku.ac.jp

Abstract

This paper presents a cutting-edge approach that harnesses daily ambient temperature fluctuations to generate usable energy for self-sustaining wireless Internet of Things (IoT) sensing systems. With conventional power sources like batteries present limitations in energy capacity, maintenance, and environmental impact, and one of the alternatives is harvesting energy from the device's surroundings. It begins by laying a solid foundation through an examination of the fundamental principles governing thermoelectric generators (TEGs). Subsequently, it delves into highlighting recent breakthroughs in TEG fabrication technologies. The paper also extensively explores phase change materials (PCMs) as crucial heat storage materials, establishing a framework that sets the stage for further research and investigations. At its core, the paper introduces the innovative concept of heat storage TEGs, bridging the gap between ambient temperature fluctuations and electricity generation. These groundbreaking TEGs leverage the dynamic shifts in ambient temperature, providing a sustainable and efficient solution for powering IoT sensors. The practical demonstration showcases a self-powered wireless sensing system capitalizing on daily ambient temperature variations. It efficiently utilizes PCMs to maintain temperature differentials that drive TEGs, resulting in electricity generation. This research underscores the feasibility and potential of such systems, emphasizing their capacity to function autonomously in real-world conditions, even without dedicated heat sources. It may contribute significantly to developing sustainable IoT technologies within our increasingly interconnected world.

POSTER PRESENTATION (Code: S3-02-P)

Green synthesis of carbon dots from pineapple peel and application for biosensor.

Phan Thanh Quyt, Mai Thi Ngoc Huyen and Vo Thi Ngoc Thuy
VNUHCM-University of Science, HoChiminh city, Vietnam
Email: thanhquyt.8727@gmail.com

Abstract

Realizing that the synthesis of carbon dots using biomass materials is both simple and benign and brings high optical and biological properties, in this project we chose pineapple peel as the precursor to manufacture the carbon dots. We choose the hydrothermal method to synthesize quantum dots with strong luminescence, uniform size, stability and high biocompatibility. Grasping the above advantages, we have successfully applied Carbon quantum dots to find metal ions with low, linear concentrations from 10^{-4} M – 10^{-7} M. The fluorescence quenching effect of these This metal ion is very strong, demonstrating the selectivity of CDs towards metal ions and can be applied for metal detection and biosensing.

POSTER PRESENTATION (Code: S3-03-P)

Research and Fabrication of Au/Fe₃O₄ Heterostructures toward Surface-Enhanced Raman Scattering (SERS) Applications

Le Thi Thu Huong, Nguyen Tran Gia Bao, Ton Nu Quynh Trang and Vu Thi Hanh Thu
Faculty of Physics and Engineering Physics, University of Science, Ho Chi Minh City, Vietnam
Email: huonglth@baubang.sgdbinhduong.edu.vn, 22C39002@student.hcmus.edu.vn

Abstract

The parameters related to the excitation wavelength, as well as the characteristics (consisting of sizes, shapes, and target molecules), significantly affect the surface-enhanced Raman scattering (SERS) enhancement factor. However, predicting the enhancement factor (EF) of sensors, which is extremely important in the quantitative and qualitative detection of hazardous molecules, still faces many challenges. Therefore, this study investigated and fabricated SERS substrates based on Fe₃O₄ semiconductor decorated with Au nanoparticles. The fabricated materials were evaluated for their crystal profiles, morphological structures, and optical properties using SEM, TEM, XRD, and UV-Vis. Meanwhile, the SERS performance of the as-prepared substrates was assessed through the detecting capability of Crystal Violet (CV) solutions. The results showed that the SERS efficiency of Au/Fe₃O₄ substrates was better than that of the pure Fe₃O₄ substrate at the same concentration of 10^{-6} M. This could be explained by the surface plasmon resonance effect of Au, which contributes to enhancing the electric field mechanism in the SERS performance.

PARALLEL SESSION

Session 4. Microelectronics, Embedded System and AI&IoT

Chair: Prof. Kyeong-Sik Min (KMU, Korea)

Co-Chair: Dr. Nguyen Chi Nhan (VNUHCM-US, Vietnam) and Prof. Jongsun Kim (Hongik University, Korea)

Secretary: Nguyen Phuoc Hoang Khang-MSc

<i>Schedule</i>	<i>Speakers</i>	<i>Title of talks</i>	
14:00-14:20	Invited talk S4-01-I Prof. Hoang Trang (VNUHCM-UT, Vietnam)	A Novel Framework, methods of AI to Optimize in Designing Analog IC	74
14:20-14:40	Invited talk S4-02-I Dr. Nguyen Chi Nhan (VNUHCM-US, Vietnam)	Predicting the content of toxic substances in aquaculture water using machine learning approaches	76
14:40-15:00	Invited talk S4-03-I Prof. Truong Ngoc Son (HCMUTE, Vietnam)	Optimized memristor crossbar array for neuromorphic computing system	79
Coffee break (15:00-15:15)			
15:15-15:35	Invited talk S4-04-I Prof. Jongsun Kim (Hongik University, Korea)	Design of on-chip clock generators for energy efficient chiplet-based systems	82
15:35-15:50	Oral S4-01-O Nguyen Hoang Trong	An Efficient Design of 45nm Charge-Pump Phase-Locked Loop Architecture for Sub-1G IoT Applications	84
15:50-16:05	Oral S4-02-O Lu Trung Tin	Enhanced Fuzzy Logic Control for Overcoming Intrinsic Resistance in Inverted Pendulum Systems	85
16:05-16:20	Oral S4-03-O Phan Tan Phuc	Optimizing Solar Energy Efficiency in Zero Energy House: An Incremental Conductance MPPT-Based Approach	86
16:20-16:35	Oral S4-04-O Tran Thi Linh	Naturalistic Driving Action Recognition and Driver Drowsiness Detection System	87
16:35-16:50	Oral S4-05-O Lam Hong Phuc	Energy Management Strategy for Decarbonized Energy Sources in DC Residential Microgrid	88
POSTER PRESENTATION: S4.01-P, S4.02-P, S4.03-P.			89-90

INVITED TALK (Code: S4-01-I)

Novel GA-OCEAN framework for automatically designing the charge-pump circuit.

Hoang Trang, Thang Nguyen Quoc and Hieu Phan Tran Minh

*Faculty of Electrical and Electronics Engineering, VNUHCM-University of Technology,
Ho Chi Minh City Vietnam
Email: hoangtrang@hcmut.edu.vn*

Abstract

Designing analog integrated circuits (ICs) can be a difficult task, due to the intricate nonlinear relationships between circuit performance metrics and design variables, as well as the complex interdependencies and trade-offs between various performance criteria. This makes it hard to determine the appropriate geometric width and length of circuit components to meet all performance specifications. This paper introduces a machine learning methodology, specifically employing the genetic algorithm (GA), to automate the selection of component sizes, aiding the work of analog circuit designers, in determining the appropriate dimensions for components within the charge-pump circuit. The GA, implemented in Python and integrated with a script program written in the OCEAN language, collaborates synergistically in the GA-OCEAN framework. The result, which ensures compliance with all specifications with remarkably low error margins ranging from 0.03% to 1.24%, highlights the proposed GA-OCEAN framework's remarkable capacity to determine optimal component sizes for the charge-pump circuit.

*Keywords: Analog circuit sizing, charge pump (CP), circuit design automation, circuit optimization, genetic algorithm (GA), phase-locked loop (PLL).

Short- Biography

Full name: Hoang Trang, Ph.D.

Academic title: Associate Professor

Institute: Ho Chi Minh City University of Technology, Vietnam National University Ho Chi Minh City, Vietnam



1. Research Areas:

- ASIC/FPGA architecture for high performance applications,
- Virtual micro-fabrication for IC and MEMS,
- AI, quantum computing, Optimization, Machine learning in IC design, in wireless communication and electronics applications.

2. Faculty/Department/Laboratory

- Department of Electronics Engineering
- Faculty of Electrical-Electronics
- IC design lab, Electronics Engineering lab.

Contacts:

Email:

hoangtrang@hcmut.edu.vn

Handphone: (+84)-988-071579

3. Research Activities

- Principal Investigators for 3 Key projects at State level, 3 projects with industries, 2 projects at city level, 4 projects at university, ministry levels.
- 3 patents, 15 IPs, related to electronics engineering.
- More than 90 publication papers. H-index: 10.
- 6 books in Embedded system, MEMS, IC design.

INVITED TALK (Code: S4-02-I)

Predicting the content of toxic substances in aquaculture water using machine learning approaches

Nguyen Chi Nhan, Van Nu Anh Thu, Cao Minh Khoi, Tran Hoang Nhut,
Ho Thanh Huy and Nguyen Phuoc Hoang Khang

Faculty of Physics and Engineering Physics, VNUHCM-University of Science, Vietnam

Email: ncnhan@hcmus.edu.vn

Abstract

Study on the structure of the convolutional neural network model. Application of convolutional neural networks to build machine learning models to predict the content of toxic substances in aquaculture water, including NO₂, pH, and NH₃/NH₄⁺. Collect color sample data of liquid solution by high-resolution camera and apply image processing to enhance the image to enrich the input data set for machine learning. The machine learning model is trained on the Google Colab platform in Python and supported by libraries for machine learning such as Tensorflow, Keras,... These machine learning models are deployed on the Raspberry Pi embedded computer to determine the content of NO₂, pH, and NH₃/NH₄⁺ substances and predict the level of influence of these substances in the aquaculture water. Also transmit this prediction result to the mobile app.

*Keywords: Machine learning, deep learning, convolutional neural networks, aquaculture water quality prediction.

Short- Biography

Full name: Nguyen Chi Nhan, Ph.D.

Academic title: Lecturer

Institute: VNUHCM-University of Science, Hochiminh City, Vietnam



Contacts:

Email: ncnhan@hcmus.edu.vn

Handphone: (+84)-903-800085

2. Research Areas

Integrated Circuit Design, Embedded System Design, Internet of Things (IoT), and Artificial Intelligence (AI)

2. Faculty/Department/Laboratory

Faculty of Physics and Engineering Physics

3. Research Activities

1. Research, design and simulation of the Ultrawide-Band transceiver for die to die communication in the chip.
2. Research and design of the PCIe Endpoint 2.0 IP core.
3. Research, design and manufacture security monitoring equipment for houses in Vietnam with low energy consumption.
4. Research and design wireless sensor network based on low power wide area network technology applied in high-tech agriculture.
5. Support equipment for the determination of NO₂, total ammonia nitrogen (TAN) and predicts its impact in aquaculture water based on machine learning.

3. Research Achievements and Awards

4. Selected Publications

1. Ching, C.T.S.; Wang, C.-K.; Tang, P.-C.; Ha, M.-K.; Li, C.; Chiu, H.-N.; Yao, F.Y.-D.; Nhan, N.C.; Hieu, N.V.; Phan, T.-L. Bioimpedance Measurement-Based Non-Invasive Method for In Ovo Chicken Egg Sexing. **Biosensors** **2023**, *13*, 440. Doi.org/10.3390/bios13040440
2. Nhan Nguyen, Khang Nguyen, Ngan Dinh and Nhut Tran. Machine learning for the assessment and prediction of nitrite in the aquaculture water. 2022 International Conference on Multimedia Analysis and Pattern Recognition (MAPR), **IEEE Xplore**, 2022. DOI: 10.1109/MAPR56351.2022.9924656
3. Khang N P H, Nhan N C. Fault classification for photovoltaic module based on max-imum power point and machine learning techniques. **Sci. Tech. Dev. J. - Nat. Sci.**; 2022, 6(4):2389-2400.

- 4.Khang N P H, Nhan N C. Solar power monitoring system based on IoT technology. **Science & Technology Development Journal – Natural Sciences, VNU-HCM**, 5(3):1482-1499, 2021.
- 5.Nhan N C, Khang N P H, Quan N H, Hieu N V, Huy H T. Design of a monitoring and control system for Aquaponics based on IoT technology. **Science & Technology Development Journal – Natural Sciences, VNU-HCM**, 4(4):800-810, 2020.
- 6.Chi Nhan N, Ngoc Tuan P, Huy Hoang N. A wireless sensor network for high-tech agriculture. **Science & Technology Development Journal – Natural Sciences, VNU-HCM**, 3(4):259-270, 2019.
- 7.Nguyen Chi Nhan, Duong Hoai Nghia, Dinh Van Anh. Design and Simulation of Pulse Generator for UWB Based on LC-Tank Differential Oscillators Topology. **Journal of Science & Technology Development, Vietnam National University HCM City**, No. T4-2015, Vol. 18, pp. 225-241, 2015.
- 8.Nhan Nguyen, Nghia Duong, Anh Dinh. A CMOS Impulse Radio Ultra-Wideband Receiver for Inner/Inter-chip Wireless Interconnection. *Journal of Institute of Korean Electrical and Electronics Engineers (IKEEE)*, Vol. 17, No. 2, pp. 176-181, June 2013.
- 9.Nhan Nguyen, Nghia Duong, Anh Dinh. A CMOS Impulse Radio Ultra-Wideband Transceiver for Inter/Intra-chip Wireless Interconnection. **Journal of Emerging Trends in Engineering and Applied Sciences (JETEAS)**, pp. 929-933, 2012.

INVITED TALK (Code: S4-03-I)

Optimized memristor crossbar array for neuromorphic computing system

Truong Ngoc Son

Faculty of Electrical and Electronics Engineering, HCM University of Technology and Education, Vietnam

Email: sontn@hcmute.edu.vn

Abstract

Memristor was mathematically proposed in 1971 by Prof. L. O. Chua as the fourth circuit elements and the first practical memristor device was introduced by R. S. William in 2008 [2]. The conductance of a memristor, also known as memristance, can be modified by programming pulses and has the ability to be maintained, making the memristor an ideal device for modelling the synaptic plasticity of bio-logical neuronal systems [3,4]. Memristor crossbar arrays have become an emerging technology for high-density neuromorphic computing systems, as an alternative to CMOS technology that is unquestionably approaching the physical scaling limits. The first interesting architecture of binary memristor crossbar for brain-inspired neuromorphic computing is the complementary crossbar that performs the logical function of Exclusive-NOR for speech and image recognition.

The twin crossbar architecture is a modified version of the complementary crossbar for low-power neuromorphic image recognition. The single crossbar architecture is then an optimized version of the complementary crossbar and the twin crossbar by shortening the Exclusive-NOR function. Single memristor crossbar is a potential architecture for neuromorphic image recognition because it can save area occupancy and power consumption, compared to the complementary and twin crossbar architectures.

In this presentation, we introduce the architecture of the complementary crossbar, the twin crossbar, and the single crossbar. We highlight the advantage of single crossbar array for neuromorphic image recognition, compared to the complementary and twin crossbar architectures. The disadvantage of single crossbar architecture is also discussed. The performance of single crossbar array strongly depend on the data density. So, to improve the performance of single crossbar array, we suggest that the images must have high data density.

*Keywords: Memristor crossbar array, neuromorphic computing system.

Short- Biography

Full name: Truong Ngoc Son, Ph.D.

Academic title: Associate Professor

Institute: Ho Chi Minh City University of Technology and Education, HCM City, Vietnam



Contacts:

Email: sontn@hcmute.edu.vn

Handphone: (+84)931085929

1. Research Areas:

- Nano-scale memristor device and its application
- Neuromorphic computing system, brain-inspired system

2. Faculty/Department/Laboratory

- Faculty of Electrical and Electronics Engineering

3. Publications (2014-now, Selected)

1. Minh Le and Son Ngoc Truong, “Statistical Study on Data Dependency of Memristor Crossbar Architectures for Neuromorphic Computing”, 2023 Applying New Technology in Green Buildings (ATiGB), Nov. 2023.
2. Le Minh and Son Ngoc Truong, “Research on the Impact of Data Density on Memristor Crossbar Architectures in Neuromorphic Pattern Recognition” *Micromachines* 14, no. 11: 1990, Oct. 2023
3. Tien Van Nguyen, Jiyong An, Seokjin Oh, Son Ngoc Truong, Kyeong-Sik Min, “Quantization, training, parasitic resistance correction, and programming techniques of memristor-crossbar neural networks for edge intelligence”, *Neuromorphic Computing and Engineering*, vol. 2, iss. 3, July 2022.
4. SN Truong, “A Ternary Neural Network with Compressed Quantized Weight Matrix for Low Power Embedded Systems”, *Engineering, Technology & Applied Science Research*, vol. 8, iss. 2, pp. 8311-8315, 2022
5. M. Le and S. N. Truong, “Memristor Crossbar Circuits for Neuromorphic pattern Recognition,” 2021 18th International SoC Design Conference (ISOCC), 2021, pp. 221-222, doi: 10.1109/ISOCC53507.2021.9613948.
6. M. Le and S. N. Truong, “Neuromorphic Character Recognition using The Single Memristor Crossbar Array,” 2021 International Conference on System Science and Engineering (ICSSE), 2021, pp. 433-436, doi: 10.1109/ICSSE52999.2021.9538471.
7. M. Le, T. K. H. Pham, and S. N. Truong, “Noise and Memristance Variation Tolerance of Single Crossbar Architectures for Neuromorphic Image Recognition”, *Micromachines*, vol. 12, no. 6, June, 2021.
8. Son Ngoc Truong, “Analysis of the Impact of Wire Resistance on Nano-scale Memristor Crossbar Array Implementing Perceptron

- Neural Network”, The 3th International Conference on Materials Engineering and Applications, Ho Chi Minh, Viet Nam, Jan. 2020, (IOP Conference Series: Materials Science and Engineering, vol 894,2020)
9. Son Ngoc Truong, “Single Crossbar Array of Memristors with Bipolar Inputs for Neuromorphic Image Recognition”, IEEE Access, vol. 8, no. 1, pp. 69327-69332, Apr. 2020
 10. Son Ngoc Truong, “A Low-cost Artificial Neural Network Model for Raspberry Pi”, Engineering, Technology & Applied Science Research, vol. 10, no. 2, pp. 5466-5469, Apr. 2020
 11. Son Ngoc Truong, “A Dynamic Threshold Quantization Method for Ternary Neural Networks for Low-cost Mobile Robots”, International Journal of Computer Science and Network Security, vol. 20, no. 2, pp. 16-20, Feb. 2020.
 12. Son Ngoc Truong, “A Parasitic Resistance-Adapted Programming Scheme for Memristor Crossbar-Based Neuromorphic Computing Systems,” Materials, vol. 12, no. 24, pp. 1-12, Dec. 2019.
 13. Son Ngoc Truong, “Compensating Circuit to Reduce the Impact of Wire Resistance in a Memristor Crossbar-Based Perceptron Neural Network,” Micromachines, vol. 10, no. 671, 2019.
 14. Khoa Van Pham, Tien Van Nguyen, Son Bao Tran, HyunKyung Nam, Mi Jung Lee, Byung Joon Choi, Son Ngoc Truong, Kyeong-Sik Min, “Memristor binarized neural networks,” Journal of Semiconductor Technology and Science, vol. 18 no. 5, pp. 568- 577, 10. 2018.
 15. Son Ngoc Truong, Khoa Van Pham, and Kyeong-Sik Min, “Spatial-pooling Memristor crossbar converting sensory information to Sparse Distributed Representation of Cortical Neurons,” IEEE Trans. Nanotechnology, vol. 17, no. 3, pp. 482-491, May, 2018

And other 25 papers.

INVITED TALK (Code: S4-04-I)

Design of on-chip clock generators for energy efficient chiplet-based systems

Jongsun Kim

School of Electronic & Electrical Engineering, Hongik University, Korea

Email: js.kim@hongik.ac.kr

Abstract

On-chip clock generators typically use phase-locked loops (PLLs) to provide the necessary frequency multiplication and phase alignment functions. Output clocks of this PLL are transmitted to computation processor cores and communication I/O blocks through clock distribution networks. Reduction of lock time or power-on time of PLLs enables aggressive power management using DVFS, thereby reducing system power consumption, and even multiprocessor SoC's per-core power management is possible. Also, it can be seen that a fast-lock PLL plays an essential role in reducing I/O power in wire-line applications composed of high-speed serial links. Although many all-digital ring oscillator-based PLLs targeting fast lock characteristics have been announced, most have a long lock time of more than several tens or hundreds of reference clock cycles.

In this talk, an all-digital MDLL-based fast lock clock generator for low-power chiplet-based SoC design is presented. The proposed all-digital MDLL measures the initial phase error using a wide-range fine-resolution time-to-digital converter (TDC) and utilizes this information to the digitally-controlled oscillator (DCO) control to implement a fast lock time of less than 6 reference clock cycles.

Keywords: PLL, phase-locked loop, MDLL, chiplet, TDC.

Short- Biography

PROF. JONGSUN KIM received the Ph.D. degree in electrical engineering from the University of California, Los Angeles (UCLA) in 2006 in the field of Integrated Circuits and Systems. He was a postdoctoral fellow at UCLA from 2006 to 2007.

From 1994 to 2001 and from 2007 to 2008, he was with Samsung Electronics as a senior research engineer in the DRAM Design Team, where he worked on the design and development of Synchronous DRAMs, SGDRAMs, Rambus DRAMs, DDR3 and DDR4 DRAMs. Dr. Kim joined the School of Electronic & Electrical Engineering, Hongik University, in March 2008. Professor Kim's research interests are in the areas of high-performance mixed-signal circuits and systems design.

His current research areas include high-speed and low-power transceiver circuits for chip-to-chip and inter-chiplet communications, clock recovery and synchronization circuits (PLLs/DLLs/MDLLs), high-speed SerDes/CDRs, frequency synthesizers, signal integrity and power integrity, DDR/GDDR/LPDDR/HBM memories, and power-management ICs (PMICs) for DDR5 DRAMs and GaN-based DC-DC converters. He currently serves as chairperson of IEEE SSCS Seoul Chapter.

ORAL PRESENTATION (Code: S4-01-O)

An Efficient Design of 45nm Charge-Pump Phase-Locked Loop Architecture for Sub-1G IoT Applications

Nguyen Hoang Trong, Ton That Bao Phuc and Hoang Trang

Depart. of Electronics Engineering, VNUHCM-University of Technology, Vietnam

Email: hoangtrang@hcmut.edu.vn

Abstract

In this era of ever-growing technology, Internet of Things (IoT) has emerged as a powerful tool for wireless communication. Compared to the higher frequency spectrum for IoT applications, the sub-1GHz network proves to be more advantageous owing to its longer range and lower power. In view of the significant contributions of phase-locked loops (PLLs) in data transmission and communication, this work introduces a charge-pump phase-locked loop (CPPLL) for sub-1G IoT applications. With an input voltage of 1.0 V and a low input reference frequency of 20 MHz, our phase-locked loop architecture is implemented in the 45 nm technology of the NCSU process. Simulation results from the Cadence Virtuoso platform indicate that our design exhibits an output frequency range from 467.3 to 877.2 MHz and RMS jitter of 150 ps, which are promising performance parameters for sub-1G IoT applications.

ORAL PRESENTATION (Code: S4-02-O)

Enhanced Fuzzy Logic Control for Overcoming Intrinsic Resistance in Inverted Pendulum Systems

Lu Trung Tin, Nguyen Tien Dat, Pham Minh Duc and Nguyen Duc Hung

VNUHCM-University of Technology, Ho Chi Minh city, Vietnam

Email: tin.luhcmut2003@hcmut.edu.vn

Abstract

The paper delves into an in-depth analysis of the intrinsic resistance of the inverted pendulum system which causes the modeling of the system to differ from the actual system. Our primary objective revolves around the implementation and subsequent optimization of fuzzy logic controllers, drawing inspiration from human perceptual assessments. The processing comprises comprehensive mathematical system modeling, intrinsic resistance examination, and improved Fuzzy logic control with detailed membership function and rule design. In addition, we conduct a comparative analysis with the widely recognized LQR algorithm, which is considered the conventional control algorithm. The result demonstrates that the improved Fuzzy Logic Controller outperforms the conventional LQR algorithm in terms of response time and overshoot mitigation, thereby underscoring its superior efficacy and optimality.

ORAL PRESENTATION (Code: S4-03-O)

Optimizing Solar Energy Efficiency in Zero Energy House: An Incremental Conductance MPPT-Based Approach

Phan Tan Phuc, Phan Quoc Dung and Pham Minh Duc

Power Electronics Laboratory, Faculty of Electrical and Electronics, Ho Chi Minh University of Technology, Ho Chi Minh city, Vietnam

Email: phuc.phan1208@hcmut.edu.vn

Abstract

The concept of Zero Energy House (ZEH) has gained traction worldwide as a vital energy-saving objective. In fact, ZEH's common challenge is to have a solution to coordinate the maximum power generation points of many independent PV systems to meet the entire local energy demand. To address this issue, this research paper introduces an approach that combines incremental conductance algorithms with load-sharing techniques for maximum power point tracking (MPPT). By continuously tracking and adjusting the operating points of individual PV arrays, the algorithm ensures that each system is operating at its peak performance, thereby maximizing energy production. Consequently, this study not only reduces waste energy but also enhances the overall sustainability of the system by optimizing energy harvesting from independent PV panels.

ORAL PRESENTATION (Code: S4-04-O)

Naturalistic Driving Action Recognition and Driver Drowsiness Detection System

Tran Thi Linh, Nguyen Duc Anh Khoi and Vo Tuan Kiet

Faculty of Electrical and Electronics Engineering, University of Technology - VNUHCM

Email: linh.tran28042001@hcmut.edu.vn

Abstract

Research on naturalistic driving and computer vision methods is currently providing a necessary solution for identifying and eliminating distracted driving behavior on the road. However, the lack of labeling information, along with low data quality and resolution has posed challenges in extracting insights from real-world driver data. Many datasets for naturalistic driver behavior recognition are often restricted in terms of access due to privacy and security concerns.

In the study, two systems are proposed: The Naturalistic Driving Behavior Recognition System used for behavior classification and the Drowsiness Detection used for distracted recognition. In the first System, the Agust dataset is constructed by the research team and then is utilized to train and select the most optimal model (our CNN model and VGG-16). These models have the task of detecting and categorizing the driver's action into 5 particular types: "Adjusting Radio", "Drinking", "Reaching behind", "Using cellphone", "Safe driving". The results demonstrate that our CNN model is the optimal model for the proposed dataset. It achieves an accuracy of 97.40% while having fewer parameters in comparison to the VGG-16, thereby improving processing speed. In System 2, Dlib's Facial Landmark Detector is implemented to detect drowsiness based on the frequency of eye blinking and yawning. By identifying the 68 crucial facial landmarks, Dlib achieves a remarkable improvement by boosting the accuracy up to 93.67%.

ORAL PRESENTATION (Code: S4-05-O)

Energy Management Strategy for Decarbonized Energy Sources in DC Residential Microgrid

Lam Hong Phuc, Le An Nhuan, Pham Minh Duc and Nguyen Duc Hung

*Faculty of Electrical and Electronics Engineering, University of Technology - VNUHCM
Email: phuc.lam1912@hcmut.edu.vn*

Abstract

In the realm of energy management and the transition from fossil fuel-based sources to renewable and environmentally sustainable energy sources, ensuring accurate power sharing in DC microgrids is a primary focus. Due to the inherent impedance mismatches within the system, guaranteeing power sharing among distributed generators poses a challenge. To overcome this problem, this study focuses on analyzing the system impedance mismatches in the DC residential microgrid, thereby proposing an output impedance modification method for distributing power reference to each distributed generator. Thereby, the power-sharing accuracy is ensured with the proposed energy management strategy even though the load power variation. Besides, the mathematical microgrid model is proven to be stable and effective through bode analysis. The potential of the proposed energy management strategy is proven through simulation and experimental with small-scale microgrid testbed.

POSTER PRESENTATION (Code: S4-01-P)

Improved Load Current Distribution with Piecewise Droop Control for Dual Active

Tran Chi Hai, Nguyen Dinh Tuyen and Pham Minh Duc

VNUHCM-University of Technology, Hochiminh city, Vietnam

Email: linh.tranpleikuk20@hcmut.edu.vn

Abstract

Effective load current distribution is a fundamental aspect of ensuring a stable and efficient DC microgrid operation particularly when utilizing dual active bridge converters. This paper entails a meticulous examination of load current distribution and the inherent characteristics of a piecewise droop controller to define an improved piecewise setpoint. Also, this study conducts a comprehensive comparative analysis involving linear and nonlinear droop-based methods. Various simulation scenarios are carried out to evaluate the practical applicability of the proposed piecewise droop controller. Our results clearly show a considerable improvement in current sharing within a particular operational range, particularly when paralleling dual active bridge converters in a DC microgrid.

POSTER PRESENTATION (Code: S4-02-P)

Simplified Double-Quadrant SoC-Based Droop Control Scheme for Balancing State of Charge in Distributed Battery Storage Systems

Tran Chi Hai, Nguyen Dinh Tuyen and Pham Minh Duc

VNUHCM-University of Technology, Hochiminh city, Vietnam

Email: hai.tranchi@hcmut.edu.vn

Abstract

In order to extend the life and prevent overcurrent of any Distributed Battery Storage Systems (DBSs), it is required to achieve the right power distribution for DC-DC converter in autonomous DC microgrids. In this paper, a simplified double-quadrant state-of-charge (SoC)-based droop control scheme is proposed to balance the SoC of each DBS unit so that the injected power becomes equalization. In particular, the proposed control scheme simplifies the mathematical equation of the droop control algorithm with n-order SoC, thereby significantly reducing the computational burden by about 30 percent. Furthermore, the proposed control

scheme does not require a communication link among DBS units, which reduces the system cost and saves the bandwidth of the existing communication network. In the analysis part, the mathematical equations that show the relationship between SoC level and output power are derived by analyzing the equivalent circuit system. Then, the simplified mathematical function in an analytic form that best fits this set of SoC data is presented. To verify the proposed approach, MATLAB, and PLECS model comprised of three DBS units is developed, and the simulation results are demonstrated in different initial SoC cases.

POSTER PRESENTATION (Code: S4-03-P)

Enhanced Power Quality in Microgrids Through Consensus-Controlled Dual Active Bridge for Mitigating Overloading and Voltage Sag

Tran Nguyen Dang Khoa, Truong Phuoc Hoa, Pham Minh Duc and Nguyen, Duc Hung

VNUHCM-University of Technology, Hochiminh city, Vietnam

Email: khoa.trannguyendang@hcmut.edu.vn

Abstract

Renewable Energy Sources (RESs) have become a prominent trend in the development of energy systems in many countries. To manage RESs, microgrids have emerged as an efficient and optimal solution. However, a microgrid might still occasionally have troublesome problems like overloading and voltage sag. To address this problem, this paper proposes a technique that combines a consensus algorithm and a dual active bridge (DAB) to transfer energy between two different microgrids. A detection technique for overloading and voltage sag is part of the suggested control approach. In these circumstances, the DAB facilitates consensus adjustments to the stable microgrid's current to bring it into balance with the overloaded current. By applying this proposed control method, voltage drops are significantly reduced, leading to an improvement in the power system's quality. Simulation results of the scaled-down microgrid are collected from the Matlab simulation platform

PARALLEL SESSION

Session 5. Computing Science, Simulation and Modeling

Chair: Prof. Huynh Van Tuan (VNUHCM-US, Vietnam);

Co-chair: Dr. Do Duc Cuong (VNUHCM-US, Vietnam);

Secretary: Dr. Trinh Thi Ly

<i>Schedule</i>	<i>Speakers</i>	<i>Title of talks</i>	
14:00-14:20	Invited talk S5-01-I <i>Dr. Vo Hong Hai</i> (VUHCM-US)	Development of an FPGA-Based Pulse-Height Analyzer for Scintillation Detectors in Gamma Energy Spectroscopy	92
14:20-14:40	Oral S5-01-O <i>Dr. Le Nguyen Hoa Tien</i>	Calculating the Wave Propagation in Cu Lao Dung Mangrove Forest (Soc Trang) using WAPROMAN model	94
14:40-15:00	Oral S5-02-O Nguyen Duy Thong	Estimation of thickness samples using gamma scattering techniques based on Machine learning approach	95
Coffee break (15:00-15:15)			
15:15-15:35	Oral S5-03-O Huynh Quoc Viet	Applied the Maximal Overlap Discrete Wavelet Transform and Short Time Fourier Transform layers for classify the electroencephalography of schizophrenia patients	96
15:35-15:50	Oral S5-04-O Phan Tung Anh	Optimization of power calculation using LQR control, stability analysis with Lyapunov Equation and Sensor fault monitoring for Wind Turbines	97
15:50-16:05	Oral S5-05-O Tran Hoang Nhut	Detection and diagnosis of rice leaf disease using deep convolutional neural network.	98
POSTER PRESENTATION: S5.01-P, S5.02-P, S5.03-P.			99-100

INVITED TALK (Code: S5-01-I)

Development of an FPGA-Based Pulse-Height Analyzer for Scintillation Detectors in Gamma Energy Spectroscopy

Vo Hong Hai, Pham Viet Hoang, Nguyen Quoc and Nguyen Tri Toan Phuc Hoang

*Faculty of Physics and Engineering Physics, University of Science, Vietnam National University
Ho Chi Minh City, Vietnam*

Email: vhai@hcmus.edu.vn

Abstract

This study presents the development of a Pulse Height Analyzer (PHA) using an FPGA-based hardware platform, specifically the National Instrument MyRIO embedded device, for scintillation detectors. Electronic pulses generated by the scintillation detector are triggered, digitized, and transferred to a buffer. A pulse height analysis tool categorizes these pulses and stores pulse-height information in registers or channels, enabling the construction of pulse-height spectra and distributions. The data is then recorded on a computer via a user-friendly interface.

The Pulse Height Analyzer was implemented using a 3-inch by 3-inch NaI(Tl) scintillation detector for gamma energy measurements, employing standard radioisotopes Na-22 and Co-60. Gamma energy spectra were acquired and analyzed. Our results demonstrate that the achieved energy resolution is comparable to that of commercial Pulse Height Analyzers, such as the EASY-MCA 2k, Ortec. Fig. 1 is the arrangement for gamma energy measurement with the uses of FPGA-based PHA and the commercial one of EASY-MCA 2k.

*Keywords: Pulse Height Analyzer, FPGA, gamma energy spectra.

Short- Biography

Mr. Vo Hong Hai got Bachelor and Master degree in Physics in Faculty of Physics - Engineering Physics, University of Science, Vietnam National University, Ho Chi Minh City. He also got Ph.D degree in Physics in Department of Earth Science, Graduate School of Science, Osaka University, Japan in 2009.

Now, Dr. Vo Hong Hai is a lecturer in Department of Nuclear Physics, Faculty of Physics = Engineering Physics, VNUHCM-University of Science. He also a Deputy head, Office of External Relations and Project managements (Since 2017-Now).

ORAL PRESENTATION (Code: S5-01-O)

Calculating the Wave Propagation in Cu Lao Dung Mangrove Forest (Soc Trang) using WAPROMAN model

Le Nguyen Hoa Tien and Vo Luong Hong Phuoc

*Department of Oceanology, Meteorology and Hydrology, Faculty of Physics and Engineering
Physics University of Science, Ho Chi Minh City, Vietnam*

Email: lnhtien@hcmus.edu.vn

Abstract

Mangrove forests provide important coastal protection services by attenuating waves, reducing erosion, and mitigating storm surge. Based on the measured wave data in 2004-2005, the study calculated wave attenuation in the Cu Lao Dung mangrove forest in Soc Trang Province, Vietnam using the WAPROMAN model. WAPROMAN simulates wave transformation processes and mangrove characteristics to predict changes in wave height. Based on Cu Lao Dung site, the model was parameterized using local bathymetry, topography, mangrove stand structure, and wave climate data. Simulations were conducted for variable mangrove widths, densities, stem diameters, and wave heights. Results showed significant wave attenuation was most influenced by mangrove width, substantially dampening waves and reducing erosion potential.

ORAL PRESENTATION (Code: S5-02-O)

Estimation of thickness samples using gamma scattering techniques based on Machine learning approach

Huynh Thanh Nhan, Le Hoang Minh, Vo Hoang Nguyen, Nguyen Duy Thong, Tran Thien Thanh and Chau Van Tao

Faculty of Physics and Engineering Physics University of Science, Ho Chi Minh City, Vietnam

Email: ngdthong@hcmus.edu.vn

Abstract

Gamma-ray scattering is a powerful method in non-destructive testing field. Many researches related to gamma-ray scattering is being used in the world. Gamma-ray scattering can be used to determine thickness, structure as well as components in a material. Along with computer science, application of computer science in many scientific fields may provide good achievements such as precision, speed of data analysis.

In this paper, Machine learning is being used in gamma-ray scattering to determine thickness of material based on gamma-ray spectrum. In order to provide a dataset for machine learning, Monte Carlo was used for Al, Ca, Co, Cu, Zn, Mg, Mn, Fe, Si, Ti samples from 1mm to 50mm. Therefore, dataset from Monte Carlo can be used for Machine learning. In Machine learning, 8th-polynomial regression method is used. The results shows that thicknesses estimation compare range uncertainties 1.4-7.5% with real thickness samples.

ORAL PRESENTATION (Code: S5-03-O)

Applied the Maximal Overlap Discrete Wavelet Transform and Short Time Fourier Transform layers for classify the electroencephalography of schizophrenia patients

Huynh Quoc Viet and Huynh Van Tuan

Faculty of Physics and Engineering Physics University of Science, Ho Chi Minh City, Vietnam

Email: hyqviet@hcmus.edu.vn

Abstract

A crucial tool for assisting early therapies that can reduce the possibility of progression to clinical psychosis is the prospective identification of persons who are experiencing schizophrenia disease. Deep learning methods and patterns using brain activity recorded by electroencephalography (EEG) are useful resources for making this diagnosis. In this research, a novel method to identify schizophrenia seizures from electroencephalogram (EEG) signals is presented, based on the maximal overlap discrete wavelet transform (MoDWT) and Short-time Fourier Transform (STFT). In order to carry out this research, we investigated MODWT's potential to break down the signals into time-frequency sub-bands up to the fifth level. Furthermore, STFT has been investigated to illustrate the spectrogram from the sub-bands. Additionally, STFT and MoDWT layers were used in the research instead of the two traditional methods STFT and MoDWT, which have been integrated into the convolutional neural network (CNN) model. The design's aim was to give a feature extraction layer with the capacity to acquire the ability to handle different signal forms while also inheriting the signal's extraction capabilities. The main outcome of the research is that the suggested method could denoise EEG and extract the features with satisfactory accuracy and clinically acceptable computational time. These benefits have turned our strategy into a desirable diagnostic and monitoring tool that aids medical professionals in giving patients better and more immediate assistance.

ORAL PRESENTATION (Code: S5-04-O)

Optimization of power calculation using LQR control, stability analysis with Lyapunov Equation and Sensor fault monitoring for Wind Turbines

Phan Tung Anh, Vo Hoang Dat, Nguyen Dinh Long Le Anh Duc and Ngo Dang Luu

Duyen Hai Thermal power company, Mu U hamlet, Dan Thanh commune, Duyen Hai town, Tra Vinh province

Email: anhatd2@gmail.com

Abstract

This paper presents a new nonlinear observer based on polynomial theory for wind energy conversion systems (WECSs). The introduced observer can estimate both the aerodynamic torque and the stator currents, eliminating the requirement for wind speed measurements. Consequently, the suggested control system only relies on the measurement of the generator rotor speed. Moreover, by reducing the number and type of sensors necessary, the overall system becomes more dependable and cost-efficient.

To achieve the optimal speed reference, we have developed the well-known LQR controller and determined its gains using a systematic procedure. Furthermore, we have conducted a comprehensive stability analysis for the polynomial observer-based LQR. Simulation results carried out with MATLAB/Simulink software have verified the effectiveness of our proposed observer and control system.

ORAL PRESENTATION (Code: S5-05-O)

Detection and diagnosis of rice leaf disease using deep convolutional neural network

Tran Hoang Nhut, Nguyen Chi Nhan and Nguyen Phuoc Hoang Khang

Faculty of Physics and Engineering Physics, University of Science, Ho Chi Minh City, Vietnam

Email: thnhut@hcmus.edu.vn

Abstract

Rice is a vital food crop globally because it is a source of food for over half the world's population. Rice diseases have significant negative effects on the quality and quantity of rice production. The accurate detection and diagnosis of rice leaf diseases are the key to avoid these negative effects. This study has considered three prevalence rice leaf diseases including leaf blast, hispa, and brown spot. A deep convolutional neural network model was proposed for the accurate detection and diagnosis of rice leaf diseases. Specifically, we used YOLOv5 and ResNet-50 to create the desired prediction model based on a large dataset that contained 3737 images of three types of rice leaf diseases. The dataset of rice leaf images was sourced from the open-source global research data platform - Kaggle. The average detection accuracies for the YOLOv5 and ResNet-50 models were 85% and 98.33%, respectively.

POSTER PRESENTATION (Code: S5-01-P)

Experimental and simulation study on the neutron flux of a Ra-Be neutron source

Phan Le Hoang Sang Huynh Truc Phuong, Tran Thien Thanh, Vo Hong Hai, Huynh Viet Lam,
Nguyen Hong Ha, Thai Thi Thanh Tuyen, Thai Phat Nguyen Thi Ngoc Hanh
and Doan Thi Thanh Nhan

*Faculty of Physics and Engineering Physics, University of Science, Vietnam National University
Ho Chi Minh City, Vietnam Vietnam*

Email: plhsang@hcmus.edu.vn

Abstract

From 1976 til now, the Department of Nuclear Physics – University of Science, VNU-HCM had used the neutron source Ra-Be for research and education. Recently, the neutron source has been utilized as a neutron source for the automatic neutron activation analysis system. In order to ensure the confidence of analytical techniques, it is necessary to determine accurately the neutron flux of Ra-Be neutron source at various positions. In this work, the Monte Carlo simulation method using MCNP program will be performed to estimate the vertical neutron flux profile of neutron source Ra-Be at various irradiation channels, whose radius is 7 cm, 14 cm and 20 cm from the source center. In the other hand, based on the neutron activation analysis method using Indium monitor and HPGe detector, the neutron flux of neutron source Ra-Be will be also measured and compared with the simulation results by Monte Carlo method.

POSTER PRESENTATION (Code: S5-02-P)

Hand and wrist movements classification using surface electromyogram

Nguyen Thi Le Thuy, Phan Nguyet Thuan and Huynh Van Tuan

*Department of Physics and Computer Science, Faculty of Physics and Engineering Physics,
University of Science, Ho Chi Minh City, Viet Nam*

Email: 20C38009@student.hcmus.edu.vn

Abstract

Myoelectric is a biological signal produced from physiological variations in muscle fibers when they contract and relax. The study of muscle activity through the recording and analysis of myoelectric signals is called electromyography. Electromyography can provide a comprehensive view of the operation and performance of internal muscle groups and cells. The objective of this study is an investigation into hand movement classification using surface electromyography (sEMG) signals. Two datasets of a publicly available database for prosthesis hand control, the

Ninapro project, were used to train and evaluate the proposed model including DB5 with low-cost 16 channels and 200 Hz sampling rate setup and DB10 with 12 channels and 1926 kHz sampling rate setup. First, we divided the EMG data into several segments using the windowing technique. These segments were then used to extract a set of time features. Finally, the retrieved feature information was loaded into a simple pattern recognition model: Artificial Neural Network.

POSTER PRESENTATION (Code: S5-03-P)

Classification of Emotions via EEG Signals by Deep Learning Approach

Vo Hoang Thuy Tien, Nguyen Thi Nhu Quynh and Huynh Van Tuan

*Department of Physics and Computer Science, Faculty of Physics and Engineering Physics,
University of Science, Ho Chi Minh City, Viet Nam*

Email: 20C38009@student.hcmus.edu.vn

Abstract

Emotion is the human brain's reaction to external stimuli. Because human emotions are complex and change in real life, research into emotion recognition is essential for real-world applications. The conventional machine learning approach, on the other hand, has a substantial downside in that the feature extraction procedure is typically time-consuming and heavily relies on human experts. End-to-end deep learning algorithms developed as a potential solution to overcome this limitation by utilizing raw signal properties and time-frequency spectrums. We investigated the use of convolutional neural networks, long short-term memory, and a hybrid model in the field of EEG-based emotion recognition. The tests were run on the well-known DEAP dataset. The CNN and CNN-LSTM models performed well in EEG-based emotion recognition, with proper extraction rates of RAW data of 89.11 and 91.47%, respectively. Parameter comparison experiments using other models, such as epoch, learning rate, and dropout probability, were also included in the study. The comparison findings reveal that the DNN model converged to optimal with fewer epochs and a faster learning rate. In contrast, the CNN model took more epochs to train. It was appropriate to cut the parameters by roughly 50% each time in terms of dropout probability.

PARALLEL SESSION

Session 6. Biomedical Engineering and Medical devices

Chair: Prof. Pham Thi Thu Hien (VNUHCM-UI, Vietnam)

Co-Chair: Dr. Huynh Chan Khon (VNUHCM-IU, Vietnam)

Secretary: Nguyen Thi Tu Trinh

<i>Schedule</i>	<i>Speakers</i>	<i>Title of talks</i>	
	Invited talk S6-01-I		102
14:00-14:20	<i>Prof. Pham Thi Thu Hien</i> (VNUHCM-UI, Vietnam)	Detection and classification of breast cancer utilizing polarization images and artificial intelligence (AI) model	
	Invited talk S6-02-I		106
14:20-14:40	<i>Dr. Huynh Chan Khon</i> (VNUHCM-IU, Vietnam)	Development of electrowetting on dielectric based digital microfluidic platform toward automated molecular biology assay	
	Oral S6-01-O	A Novel Cancer Cells Recognizer Tracking Starvation-Induced Lipid Trafficking into Mitochondria	110
14:40-14:55	Dinh Thanh Dat		
Coffee break (15:00-15:15)			
	Oral S6-02-O	Denoising And Enhancing Image Quality For Detection Accuracy In Mammograms	111
15:15-15:35	Hua Thi Hoang Yen		
	Oral S6-03-O	Maintaining the Postharvest Fruit Quality using UV-C LED System	112
15:35-15:50	Le, Thi Thu Ngoc (Taiwan)		
	Oral S6-04-O	Development of a handheld impedance analyzer using AD5941	113
15:50-16:05	Phan Thien Luan (Taiwan)		
POSTER PRESENTATION: S6.01-P, S6.02-P, S6.03-P.			114-115

INVITED TALK (Code: S6-01-I)

Detection and classification of breast cancer utilizing polarization images and artificial intelligence (AI) model.

Pham Thi Thu Hien

School of Biomedical Engineering, International University, *Vietnam National University Ho Chi Minh City, Vietnam Vietnam*

Email: ptthien@hcmiu.edu.vn

Abstract

Breast cancer, which occurs when cells in the breast begin to grow uncontrollably, is the leading cause of death in women and has become a major health problem globally. Mammography and ultrasound are considered the gold standard in breast cancer diagnosis and screening. To analyze breast cancer images in terms of molecular size, polarization imaging is emerging as a new promising tool in cancer diagnosis in general. This study uses polarization images of Mueller matrix transformation to determine the grade of breast cancer. A polarized imaging system includes a He-Ne laser source, polarizers and quarter waveplate are set up to capture polarized images through a CCD camera for 4 different types of breast tissue including normal breast tissue, benign tumors, grade 1 and grade 2 of breast cancer. The achieved dataset is then fed into the ResNet-18 and Random Forest models to evaluate and uncover their forms, structures, and characteristics of polarization images. The overall performance of these models is achieved over 0.88 of accuracy, recall, and F1-score. This study may enable increasing more accuracy and greatly supporting to doctors in diagnosing medical conditions of patients.

*Keywords: Breast cancer, Polarization imaging, Backscattering, Mueller matrix transformation, Deep learning, ResNet-18, Random Forest.

Short- Biography

Full name: Pham Thi Thu Hien, Professor, Ph.D.

Academic position: Associate Professor

Job's position: Head of Biomedical Photonics Lab, Chair - Department of Medical Instrumentation, School of Biomedical Engineering, International University – Vietnam National University HCMC, Ho Chi Minh city, Viet Nam.



Contacts:

Email address:

ptthien@hcmiu.edu.vn

Handphone: (+84) 0909065306

Website of personal/ lab/dept:

<https://scholar.google.com/citations?user=Tk3749sAAAAJ&hl=en>

1. Research Areas:

- Polarized light-tissue studies/ optical techniques in precision measurement
- Applications of artificial intelligence (AI) or signal/ image processing for detection/ classification.
- Cancer detection (skin, liver, and breast ...) and cell/ tissue characterization
- Noninvasive glucose measurement

2. Education:

- Ph.D: 2007 – 2012, National Cheng Kung University, Taiwan
- Master: 2005 – 2007, Southern Taiwan University Of Science And Technology, Taiwan
- Bachelor/Engineer: 1998 – 2003, Ho Chi Minh City University Of Technology – Vietnam National University HCMC.

3. Academic Activities:

Members of academic society (name of society, position, where, when)

- 2021 Applied Optics, Reviewer
- 2021 Journal of Biomedical Optics, Reviewer
- 2022 Jove: Methods collections_Current Methods for Studying Cells and Tissues Using Polarized Light, Guest Editor.

Invited talks for International conference/workshop (name of talk, name of conference/workshop, where, when)

- Invited talk, The 8th international conference on photonics and applications, Da Nang, Vietnam, Aug. 2014...
- Session chair, 8th International Conference on the Development of Biomedical Engineering in Vietnam - July 2020 (IFMBE Proceedings, Springer)
- Session chair, 9th International Conference on the Development of Biomedical Engineering in Vietnam – December 2022 (IFMBE Proceedings, Springer).

Academic supervisor for master/Ph.D thesis (name of title thesis, university/institute, where, when)

- Master thesis: Phan Lại Nhật Minh, “Building a polarization measuring system of the Stokes parameters applying in diagnostic detection”, 2018.
- Master thesis: Bùi Thị Ngọc Phương, “Extracting effective optical parameters of breast cancer cell line-BT474 for cancerous detection”, 2018.
- Master thesis: Nguyễn Lê Ý, “Design and construction of an automatic UV polarimeter for characterizing biomaterials”, 2022.

4. Research Achievements and Awards:

Research projects (2010-now): Chief of Project

- [1]. “Designing and building an optical system for measuring the polarized of light utilizing in biomedical applications to diagnose diseases” the researching project, No. 167/2013 / HD-SKHCHN, The Department of Science and Technology, 2013 – 2015, (Principal Investigator).
- [2]. “Manufacturing and applying the polarized light system to detect the diseases on tissue”, the researching project from Vietnam National Universities – HCMC (VNU-HCM) under grant number C2016-28-10, 2016-2018, (Principal Investigator).
- [3]. “Characterization of nine effective parameters of liver cancer cells / tissues utilizing the Mueller matrix method and Stokes polarimeter”, the researching project from National Foundation for Science and Technology (NAFOSTED) under grant number 103.03-2016.86, 2017-2019, (Principal Investigator).
- [4]. “Detection and classification of cancer diseases utilizing the polarized light optical system and deep neural networks”, the researching project from Vietnam National University – HCMC (VNU-HCM) under grant number DS2020-28-02, 2020-2022, (Principal Investigator).
- [5]. “Classification of skin and breast cancer stages based on the polarization states and deep learning”, the researching project from National Foundation for Science and Technology (NAFOSTED) under grant number 103.03-2019.381, 2020-2022, (Principal Investigator).
- [6]. “Research and application of AI models combining to polarization images and biomedical images for diagnosis of some cancers”, the researching project from Vietnam National University – HCMC (VNU-HCM) under grant number DS2023-28-02, 2023-2026, (Principal Investigator).

Intellectual Property

- [1]. “Research on New Polarized Optical Inspection System for Anisotropic Optical Materials and Bio-Tissue,” the researching project, National Science Council Taiwan, 2009-2012

Books

[1]. Stokes–Mueller Matrix Polarimetry: Effective Parameters of Anisotropic Turbid Media: Theory and Application. In: Mazumder, N., Kistenev, Y.V., Borisova, E., Prasada K., S. (eds) Optical Polarimetric Modalities for Biomedical Research. Biological and Medical Physics, Biomedical Engineering. Springer, Cham., 2023 https://doi.org/10.1007/978-3-031-31852-8_3

Research Awards

- Certificate of Merit from Minister of the Vietnam Ministry of Education and Training for successfully completing the task for 2 academic years from the 2019 - 2020 to the 2020 – 2021.
- "Excellent completion of the task" award by the International University for the academic year of 2018-2019, 2019-2020, 2020-2021, 2021-2022, and 2022-2023.
- "Grassroots-level Emulation Fighter" award by the International University for the academic year of 2019-2020, 2020-2021, 2021-2022 and 2022-2023.
- Certificate of Merit from the Director of Vietnam National University-HCM for individuals with outstanding achievements in teaching and awarded Lecturer of the Year 2022.
- Award of the 3rd Ho Chi Minh City Creativity Award - 2023 (Third prizes).
- Award of the 27th Ho Chi Minh City Technical Innovation Contest – 2023 (Third prizes).

5. ISI/Scopus/SCIE Selected Publications (2010-Now): 20

INVITED TALK (Code: S6-02-I)

Development of electrowetting on dielectric based digital microfluidic platform toward automated molecular biology assay.

Ngo Yen Khanh¹, Nguyen Van Hieu², Nguyen Tien Anh³ and Huynh Chan Khon¹

¹*School of Biomedical Engineering, International University and ²Faculty of Physics – Engineering Physics, University of Science*

Vietnam National University Ho Chi Minh City, Vietnam Vietnam;

³*Faculty of Physics and Chemical Engineering, Le Quy Don Technical University, Hanoi, Vietnam*

Email: hckhon@hcmiu.edu.vn

Abstract

Electrowetting-on-dielectric based digital microfluidics (DMF) has emerged as a promising technology for precise liquid manipulation in miniaturized systems, finding applications in various fields such as healthcare, diagnostics, and chemical analysis. The choice of substrate surface significantly influences the performance and reliability of DMF devices especially when it comes to application on biological samples. This study presents a comprehensive investigation into three surface types to assess their impact on DMF functionality. The study employs a systematic approach, involving surface characterization techniques, wetting behavior analysis, and experimental validation through digital microfluidic operations. Additionally, the study evaluates the long-term stability and durability of DMF devices on each surface type, addressing concerns related to surface degradation and performance degradation over time. Our results reveal distinct advantages and challenges associated with each surface type. Cost effective surface that adheres to standard manufacturing practices as well as environmentally friendly alternative protocols may present challenges in terms of surface uniformity and therefore, may pose issues in achieving optimal electrowetting behavior. In opposite, surfaces exhibit improved smoothness, stability and enhanced electrowetting characteristics come at a higher manufacturing cost. Our study underscores the importance of surface selection in optimizing

digital microfluidic systems for diverse applications, paving the way for advancements in this rapidly evolving field.

*Keywords: electrowetting on dielectric, digital microfluidic, electrode surface

Short- Biography

Full name: Huynh Chan Khon, Ph.D.

Academic title: Lecturer

Institute: School of Biomedical Engineering, International University – Vietnam National University in Ho Chi Minh City, Vietnam



Contacts:

Email: hckhon@hcmiu.edu.vn

Handphone: (+84) 902884865

1. Research Areas:

- Point-of-care diagnostics
- Lab-on-a-chip, microfluidics, lateral flow assay
- Vascular biology

2. Faculty/Department/Laboratory

- School of Biomedical Engineering
- Lab on a chip and biosensors

3. Research Activities

1. **University Lecturer**, School of Biomedical Engineering, International University – Vietnam National University in Ho Chi Minh City, Vietnam, 2014 – present
2. **Friend**, Vietnam Young Academy, 2017-present
3. **Researcher (Sabbatical Leave)**, Dynamics of Viral Structures group, Heinrich Pette Institute – Leibniz Institute of Experimentelle Virologie, 2019-2020
4. **Member**, International Society of Hemostasis and Thrombosis (ISTH), 2017-2018
5. **Organizer**, Vietnam-UK Newton Workshop “Microfluidics, Nanomaterials, and Point-of-Care in Healthcare for developing countries”, 2018
6. **Local organization committee, Session Chair** (Tissue Engineering & Regenerative Medicine) - The 6th and 7th International Conference on the Development of Biomedical Engineering in Vietnam, 2016 & 2018
7. **Researcher and Postdoctoral Researcher**, Vascular Biology Group IHTM, University Hospital of Dusseldorf, Germany, 2009-2014
8. **Researcher**, Biotherapeutics Group - Biotechnology center of Ho Chi Minh city, Vietnam, 2009

9. **Researcher**, Molecular Biology Laboratory, Ajou University, Korea, 2006-2009

4. Research Achievements and Awards:

Research Awards

1. **ISTH Fellowship Award 2018**, International Society of Thrombosis and Hemostasis (<https://www.isth.org/news/392202/Meet-the-Newest-Reach-the-World-Fellows.htm>), 2018
2. **Excellent Scientific Publication Award**, International University, Vietnam, 2017
3. **Abstract achievement award and Travel grant award**, ISTH Meeting in Kyoto, Toronto and Berlin, 2011, 2015 & 2017
4. **Scholarship for outstanding academic achievement**, University of Agriculture and Forestry, Ho Chi Minh, Vietnam, 2005 & 2006

5. Selected Publications (2014-now)

1. Tran Doan Hong Ngoc , Nguyen Ngoc Phuong Uyen, Nguyen Phuong Thao, Le Minh Thong, Nguyen Thi Thu Hoai, Huynh Chan Khon: DEVELOPMENT OF A LATERAL FLOW IMMUNOASSAY WITH SILVER ENHANCEMENT FOR DETECTING Staphylococcus aureus α -HEMOLYSIN. Applied Biochemistry and Microbiology : Accepted (August 2023).
2. Le, H., Mai-Thi, H.-N., Le, X., Tran, N. Q., Tu Tran, C., & Huynh, K. (2022). The concentration-independence cellular effects of fibronectin adsorbed on material surfaces with different hydrophobicities. Vietnam Journal of Biotechnology, 20(3), 435–444. <https://doi.org/10.15625/1811-4989/16585>
3. Le, Phong, Mai-Thi, Hoang-Nghi, Stoldt, Volker R., Tran, Ngoc Quyen and Huynh, Khon. "Morphological dependent effect of cell-free formed supramolecular fibronectin on cellular activities" Biological Chemistry, vol. 402, no. 2, 2021, pp. 155-165. <https://doi.org/10.1515/hsz-2019-0402>
4. Thien Hoang, Bao-Han Ly, Thanh-Xuan Le, Thanh-Thao Huynh, Hoang-Tuan Nguyen, Toi Van Vo, Thi Thu Hien Pham, Khon Huynh. MINIMAL MICROFABRICATION REQUIRED DIGITAL MICROFLUIDIC SYSTEM TOWARD POINT-OF-CARE NUCLEIC ACID AMPLIFICATION TEST APPLICATION FOR DEVELOPING COUNTRIES. Microsystem Technology 26, 1863–1873 (2020).
5. Hoang-Tuan Nguyen, Ha Thach, Emmanuel Roy, Khon Huynh*, Cecile Mong-Tu Perraul*, LOW-COST, ACCESSIBLE FABRICATION METHODS FOR MICROFLUIDICS RESEARCH IN LOW-RESOURCE SETTINGS. Micromachines 2018, 9, 461
6. Phung Ngan Le, Chan Khon Huynh, Ngoc Quyen Tran. ADVANCES IN THERMOSENSITIVE POLYMER-

- GRAFTED PLATFORMS FOR BIOMEDICAL APPLICATIONS. *Material Science and Engineering C*, 2018
7. Huong Nguyen, Khon Huynh* and Volker R Stoldt. SHEAR-DEPENDENT FIBRILLOGENESIS OF FIBRONECTIN: IMPACT OF PLATELET INTEGRINS AND ACTIN CYTOSKELETON. *Biochemical and Biophysical Research Communications*, 2018
 8. Alexander Assmann, Marc Struß, Franziska Schiffer, Friederike, Heidelberg, Hiroshi Munakata, Elena V. Timchenko, Pavel E. Timchenko, Tim Kaufmann, Khon Huynh, Yukiharu Sugimura, Quentin Leidl, Antonio Pinto, Volker R. Stoldt, Artur Lichtenberg, Payam Akhyari; IMPROVEMENT OF THE IN VIVO CELLULAR REPOPULATION OF DECELLULARIZED CARDIOVASCULAR TISSUES BY A DETERGENT-FREE, NON-PROTEOLYTIC, ACTIN DISASSEMBLING REGIMEN. *Journal of Tissue Engineering and Regenerative Medicine* 2017. IF: 4.71
 9. Tran Ngoc Quyen, Vo Van Toi, Nguyen Thi Hiep, FABRICATION OF ELECTROSPUN POLYCAPROLACTONE COATED WITH CHITOSAN-SILVER NANOPARTICLES MEMBRANES FOR WOUND DRESSING APPLICATIONS, *J Mater Sci: Mater Med* (2016) 27:156, IF 2.272
 10. K. Huynh, M. Gyenes, C. P. Hollenberg, TH. Nguyen, TV Vo, V. R. Stoldt, FIBRONECTIN UNFOLDED BY ADHERENT BUT NOT SUSPENDED PLATELETS: AN IN VITRO EXPLANATION FOR ITS DUAL ROLE IN HAEMOSTASIS, *Thrombosis Research* 136 (2015) 803–812

ORAL PRESENTATION (Code: S6-01-O)

**A Novel Cancer Cells Recognizer Tracking Starvation-Induced Lipid Trafficking
into Mitochondria**

Dinh Thanh Dat, Min-Wei Wu and Cheng-Chung Chang
Graduate Institute of Biomedical Engineering, National Chung Hsing University, Taiwan

Email: dinhthanhdatt7796@gmail.com

Abstract

The shock sensor provides protection to equipment during operation by detecting sudden speed changes. This article presents the design of a micro-level shock sensor that is able to detect acceleration values in two different threshold ranges. This structure includes a moving mechanism, a thermoelectric mechanism that restores the sensor, and capacitive sensing mechanisms that convert the displacement signal to an electrical signal. The sensor is based on a compliant multi-stable mechanism so that it will be able to operate with high precision and saving a large amount of energy. An investigation of the characteristics of moving mechanisms is conducted using finite element methods and numerical calculations. The influence of current and temperature on the displacement of the reset mechanism was also investigated. Two acceleration values of 13 g and 48 g are detected by an optimized shock sensor structure.

ORAL PRESENTATION (Code: S6-02-O)

Denoising And Enhancing Image Quality For Detection Accuracy In Mammograms

Hua Thi Hoang Yen and Nguyen Hong Giang

*Physics and Engineering Physics, University of Science,
Vietnam National University -Ho Chi Minh city, VietNam
Email: dinhthanhdatt7796@gmail.com*

Abstract

Since mammography was introduced in the middle of the 20th century, it has been the preferred method for detecting breast cancer, thereby significantly impacting the prognosis and survival rates of affected individuals. However, the diagnostic accuracy of mammographic images can be compromised by the presence of noise, low contrast, fuzzy nature and low differentiability from the surrounding. In this paper, we present a comprehensive approach for denoising and enhancing mammograms through a combination of new wavelet-based denoising and morphological transformation that addresses these limitations. By applying various shrink thresholding to the detail subbands of stationary wavelet, we reduce the impact of noise artifacts without significantly compromising image features. Subsequently, a new method for morphological filtering operation is applied to further enhance contrast and suppress noise but still refine the edges, remove unwanted artifacts and emphasize relevant structures. The experimental results outperformed existing methods in terms of quantitative metrics such as PSNR, SSIM... This proposed method is a promising new method for denoising and enhancing mammograms, which has the potential to contribute to earlier and more accurate breast cancer diagnosis, thereby further advancing the field of women's health and cancer detection.

ORAL PRESENTATION (Code: S6-03-O)

Maintaining the Postharvest Fruit Quality using UV-C LED System

Le Thi Thu Ngoc, Yang Tsung-Hsun, Lia Chung-Ta and Sun Ching-Cherng

Department of Optics and Photonics, National Central University, Taoyuan, Taiwan

Email: lttngoc.1994@gmail.com

Abstract

Antifungal effects of ultraviolet C (UV-C) irradiation have been considered a potential solution to reduce the severity of black spots on postharvest fruits. In this work, a $30 \times 30 \times 30$ cm system was made based on UV-C light-emitting diodes (LEDs) to apply in reducing disease symptoms for bananas which could be used in industrial conveyor belts. The UV-C irradiance monitoring was carefully carried out for several sections at various box heights in simulation and measurement. The findings experienced a dominating range of 6 to 9 W/m² in the central sections. Regarding in vivo conditions, the observation after a week from the experiment showed that the disease symptoms on the UV-C-treated banana peel, which was exposed under UV-C light for around 5 seconds, dramatically decreased compared to a natural banana. Consequently, the UV-C dose range is proposed from 0.030 to 0.045 kJ/m² with minimum damage in terms of sensory properties. Owing to the flexible shape and short exposure time, the system promises to provide many potential applications to prolong the quality of bananas.

ORAL PRESENTATION (Code: S6-04-O)

Development of a handheld impedance analyzer using AD5941

Tran Ngoc Luan, Ching Congo Tak Shing, Ha Phan Ngoc Quan, Phan Thien Luan
and Ha Minh Khue.

Department of Optics and Photonics, National Central University, Taoyuan, Taiwan
Email: ptluan@hcmus.edu.vn

Abstract

Impedance analyzers and supporting software play a major role in impedance measurement but most of them are expensive and large in size, making them unsuitable for environments outside the laboratory. Therefore, this study proposes a cost-effective, small-size, and portable impedance analyzer using the IC AD5941 that makes frequency sweep measurement for various applications. The AD5941 is a high precision impedance converter system that consists of a 16-bit, 1.6 MSPS, analog to digital converter (ADC), an integrated waveform generator, and a digital signal processor (DSP) block. The AD5941 has many advantages over its predecessor, the AD5933, which was used in numerous studies in the past decade. The design utilizes a microcontroller and an AD5941 analog front-end circuit for impedance measurement. Also, the device implements the four-wire impedance method which is an impedance measuring technique that reduces the effect of electrodes to get higher accuracy. A supporting software GUI is employed to control the AD5941 impedance analyzer and to visualize the measurement. This impedance analyzer achieves a frequency resolution of 0.015Hz and can generate sinusoid waveform in the range of 10kHz to 150kHz. The device can measure impedance up to 200kOhm with less than 3 percentage of error in comparison with commercial available device, the Microtest 6632 impedance analyzer (New Taipei city, Taiwan).

POSTER PRESENTATION (Code: S6-01-P)

MRI Brain Tumor Image Enhancement And Segmentation Base on BEMD and Morphological Operations

Nguyen Hong Giang and Hua Thi Hoang Yen

*Faculty of Physics and Engineering Physics, University of Science, Vietnam National University
Ho Chi Minh City, Vietnam Vietnam*

Email: honggiang810@gmail.com

Abstract

One of the most crucial stages of medical image analysis is segmentation as it provides valuable information for brain tumor identification, tracking, and treatment. Recently, several AI-based systems that can precisely do this task have been developed. Despite this, the segmentation procedure is challenging since a number of tumors resemble normal brain regions and have a low contrast or invisible appearance. These led researchers to develop novel methods for improved image segmentation and image preprocessing. This article aims to enhance the quality of an MRI brain tumor image by using morphological operations and the Bidimensional Empirical Mode Detection (BEMD) algorithm to produce an improved image that preserves object edges and then, tumors are extracted and segmented by using image quantization method with multithreshold.

POSTER PRESENTATION (Code: S6-02-P)

Application of Machine learning in detecting chicken egg gender by non-invasive method

Nguyen Ngoc Thao Nhi, Ho Thanh Huy, Nguyen Anh Huy, Phan Thien Luan, Cu Duy Anh
and Huynh Thanh Hien

*Faculty of Physics and Engineering Physics, University of Science, Vietnam National University
Ho Chi Minh City, Vietnam Vietnam*

Email: nntnhi@hcmus.edu.vn

Abstract

Poultry and poultry products are essential and nutritionally rich food sources for humans, not only in Vietnam but also around the world, with chicken being one of them. However, the poultry farming industry, especially in the breeding of chickens and egg-laying hens, is facing a significant challenge in how to control the gender of chickens while they are still in the egg and reduce the cost of raising them. Therefore, recent research has focused on finding ways to detect the gender of chickens in eggs using non-invasive methods that do not affect the development

of the chickens. The impedance analysis method, which has been widely applied to the human body, living animals, and biomedical research, is gaining significant attention. This will be a new method to apply in analyzing impedance signals during the egg incubation process and predicting the gender of chickens in the eggs. In addition, nowadays, Artificial Intelligence (AI) and Machine Learning are also widely applied in the field of livestock farming, helping to provide quick predictions without incurring high costs or labor. Based on this advantage, Machine Learning is applied in the project to create an optimal model for gender identification of chickens in eggs within the shortest incubation time (approximately less than 14 days). Data was collected from over 200 eggs in Taiwan, with each egg having four electrodes attached and placed in an incubation chamber for 14 days, measuring frequencies from 100kHz to 8MHz. The data collected will be processed and applied to models using the Support Vector Machine (SVM) algorithm.

POSTER PRESENTATION (Code: S6-03-P)

Deep learning model in classification Parkinson's Disease via EEG signals

Nguyen Thi Nhu Quynh, Vo Hoang Thuy Tien and Huynh Van Tuan

*Faculty of Physics and Engineering Physics, University of Science, Vietnam National University
Ho Chi Minh City, Vietnam
Email: ntnquynh@hcmus.edu.vn*

Abstract

Parkinson's disease is highly prevalent and has a significant impact on sufferers' daily activities. The number of persons affected by this condition is currently over 10 million worldwide, and it is predicted to rise sharply in the years afterward. It is not possible to fully treat this illness at this time. The substantia nigra's loss of dopaminergic neurons is the primary cause of common symptoms such as bradykinesia, stiffness, and tremors. Because this disease is directly related to the brain, our research uses Electroencephalography (EEG) signals to diagnose it. The dataset includes 56 participants, of which 28 patients (at ON and OFF condition) with PD and 28 match age and sex people. Their EEG signals were collected via Simon's Conflict task. Our proposed model is a combination of Independent Component Analysis (ICA) and Convolution Neural Network (CNN). Signals after denoised by the ICA method, were applied to the CNN model to diagnose. The deep learning model shows outstanding results when classifying three labels: healthy, PD at ON condition, and PD at OFF condition with 94.8%, 99.1%, and 98.9%, respectively.

Plan for the 5th International Conference on Engineering Physics, MEMS-Biosensors and Applications (ICEBA2024)

November, 2024; Vietnam

1. The scope of Conference

The purpose of the 5th ICEBA2024 is to link the researchers, scientists from Vietnam, Australia and Asian countries in the field of Engineering Physics and microelectronics and semiconductors for their applications in biomedical engineering, health sciences, hi-tech agriculture and smart cities. Besides, we also contribute to promoting international cooperation activities on joint research projects and international co-publications.

2. The subject areas

Contributed papers must be the new research works and are solicited in the following subject areas (but not limited to):

- *Applied Physics, Engineering Physics, Electronic Engineering and Nuclear Engineering;*
- *MEMS (MicroElectronMechanical System), Sensors, Biosensors and semiconducting devices;*
- *Microelectronics, IC design, low consumption devices, Renewable Energy*
- *Computing Science, Simulations and Modeling;*
- *Embedded systems, Internet of Things, Machine Learning, Artificial Intelligence,..*
- *Biomedical Engineering, Digital Microfluidics and their applications;*
- *Other...*

3. Time: 02 days in November

- 1st day: Registration, Opening Ceremony & Plenary talks, Poster session, Parallel sessions, Meeting of 5th ICEBA2024 and Conference party.
- 2nd day : Tutorial Session and City tour.

4. Venue: Mekong delta area, Vietnam.

5. Co-organizers: University of Science (VNUHCM, Vietnam), Tohoku University (Japan) and other university.

6. Committees of 5th ICEBA2024 (TBC):

7. Sessions:

*Oral Sessions:

- . Session 1. Applied Physics, Engineering Physics, Nuclear Engineering
- . Session 2. Semiconductor Technologies, Materials, Device and Related
- . Session 3. MEMS, Biosensors and Application
- . Session 4. Microelectronics, Embedded System and AI&IoT
- . Session 5. Computing Science, Simulation and Modeling
- . Session 6. Biomedical Engineering and Medical devices
- . Session 7 Others

* Poster Session

8. Call for paper: 1 st announcement in Jan 2024

9. The Secretary

Address: 227 Nguyen Van Cu Street, District 5, Ho Chi Minh city, Vietnam.

Email: 5iceba2024@gmail.com

Contact: Office of Faculty of Physics and Engineering Physics, A Building

Website: <https://phys.hcmus.edu.vn/ICEBA2023/#/>