

# The 3<sup>rd</sup> International Workshop on Engineering Physics, IC-MEMS-Sensors and Their Applications

(3<sup>rd</sup> IWEMA2022)

VNUHCM-University of Science, November 25&26, 2022

Venue: 227 Nguyen Van Cu Street, District 5, Hochiminh City, Vietnam



## Abstract and Program

### The 3<sup>rd</sup> International Workshop on Engineering Physics, IC-MEMS-Sensors and Their Applications (3<sup>rd</sup> IWEMA2022)

VNUHCM-University of Science, Vietnam

November 25&26, 2022

\*The IEEE Solid-State Circuits Vietnam Chapter;  
\*Ho Chi Minh Semiconducting Industrial Association (HSIA);  
\*Institute of Korean Electrical and Electronic Engineers (IKEEE, Korea)

Host & Organizers:



**HCMUS**  
Viet Nam National University  
Ho Chi Minh City



Technical Supports



한국전기전자학회  
INSTITUTE OF KOREAN ELECTRICAL AND ELECTRONICS ENGINEERS

## Technical Program

The 3<sup>rd</sup> International Workshop on Engineering Physics, IC-MEMS-Sensors  
and Their applications (3rd IWEMA2022)

(Satellite conference of 13th Scientific Conference of University of Science in 2022)  
25&26, November, Ho Chi Minh City, Vietnam

Host by Faculty of Physics- Engineering Physic, University of Science ,  
Vietnam National University- HCMC)  
and Ono-Toda Lab, Tohoku University, Sendai, Japan

-----

### \*1st day of workshop (November 25, Friday)

Time	Contents/Program	Note
08:00-08:45	Registration (Check list, nameplate, Abstract&Program,...)	-Lobby of conference room C33 (Building C, 3 <sup>rd</sup> floor) -The secretary
<b>1.OPENING CEREMONY</b> Conference room C33, Building C, 227 Nguyen Van Cu Str., District 5, HCMC		
09:00-09:10	<b>1. Introduce Guests (MC)</b>	<i>MC: Dr. Ho Thanh Huy (VNUHCM-US)</i>
09:10-09:25	<b>2. Welcome speeches:</b> - Welcome speech from VNUHCM-US - Speech from General Chair of 3 <sup>rd</sup> IWEMA2022 - Speech from Program Chair of 3 <sup>rd</sup> IWEMA2022 - Speech from HSIA	
09:25-09:35	<b>3. Offer the gifts for invited speakers</b> . Plenary speakers. . Invite speakers	<i>Prof. Huynh Van Tuan Dean, Faculty of Physics- Engineering Physics</i>
09:40-09:50	<b>4. The MoA signing ceremony for the 4<sup>th</sup> IWEMA2023</b> . University of Science, VNUHCM . Ono lab, Tohoku University, Japan . IKEEE, Korea . Ho Chi Minh Semiconducting Industrial Association (HSIA)	The representative of 5 units.
09:50-10:00	<b>Coffee break</b>	Lobby
10:00-11:30	<b>5. Plenary session: 20 min for talk and 5 min for discussion</b> <i>Chair: Assoc. Prof. Nguyen Van Hieu (VNUHCM)</i> <i>Technical Assistant: Nguyen Hoang Quan-MSc (0938.551383)</i> Link google meet for online: <a href="https://meet.google.com/uda-ejty-dkz">https://meet.google.com/uda-ejty-dkz</a>	Nanoengineered Microsystems IoT, Health and Environment Applications
	<b>. Plenary #1 (code: PL-01).</b> <b>Prof. Takahito Ono</b> <i>Tohoku University, Japan</i>	

	<b>. Plenary #2 (code: PL-02)</b> <b>Prof. Kyeong-Sik Min</b> <i>Kookmin University, Seoul, Korea</i>	Processing-in-memory for energy-efficient edge computing
	<b>. Plenary #3 (code: PL-03)</b> <b>Prof. Congo Tak Shing Ching (online)</b> <i>National Chung Hsing University, Taiwan</i>	Non-invasive diagnosis and measurement by electrical impedance spectroscopy
	<b>. Plenary #4 (code: PL-04)</b> <b>Prof. Dao Viet Dzung (online)</b> <i>Griffith University, Australia</i>	MEMS Sensor for Industry and Smart Cities

## 2. POSTER SESSION 11:30-12:00;

Lobby of Conference room C33, Building C, 227 Nguyen Van Cu Str., District 5, HCMC

- Chair: Assoc. Prof. Huynh Van Tuan (VNUHCM-US, Vietnam)

- Co-Chair: Dr. Nguyen Chi Nhan (VNUHCM-US, Vietnam)

<i>Code</i>	<i>1<sup>st</sup> Author/ speaker</i>	<i>Name of poster presentation</i>
<b>PO-01</b>	<b>Ngo Yen Khanh-Master student</b> <i>International University, VNUHCM, Vietnam</i>	Development of a Digital Microfluidics system for point-of-care molecular diagnostics
<b>PO-02</b>	<b>Nguyen Hoang Quan-MSc</b> <i>University of Science, VNUHCM, Vietnam</i>	The study of lithography parameters for the fabricating process of nMOS electrodes
<b>PO-03</b>	<b>Nguyen Phuoc Hoang Khang-Master student</b> <i>University of Science, VNUHCM, Vietnam</i>	Application of deep learning in fault detection using thermal image for Photovoltaic panel.
<b>PO-04</b>	<b>Tran Hoang Nhut-Master student</b> <i>University of Science, VNUHCM, Vietnam</i>	IoT System for Aquaponics garden with vegetables and fishes
<b>PO-05</b>	<b>Nguyen Hoang Long- Master student</b> <i>University of Science, VNUHCM, Vietnam</i>	SERS Sensor based on Ag Nanoparticles for fast detection of fast GREEN FCF
<b>PO-06</b>	<b>Ha Minh Khue- Master student</b> <i>University of Science, VNUHCM, Vietnam</i>	Design and implementation fo Doppler radar system target classification using deep learning
<b>PO-07</b>	<b>Tran Thien Minh-BSc</b> <i>University of Science, VNUHCM, Vietnam and Company.</i>	The equipment for testing food 's quality using the image by machine learning.
<b>PO-08</b>	<b>Le Hong Nhung-BSc</b> <i>University of Science, VNUHCM, Vietnam and Company.</i>	Checking diseases through cantaloupe leaves using Convolutional Neural Network (CNN) Algorithm

Lunch time (12:00-12:50)

## 3. PARALLEL SESSION: 13:00-17:00 (12 min for talk and 3 min for discussion)

### Session 1. MEMS, Sensors and Electronics Devices

Room: C31, Building C, 227 Nguyen Van Cu Str., District 5, HCMC

- Chair: Prof. Takahito Ono (Tohoku University, Japan)
- Co-Chair: Assoc. Prof. Nguyen Van Hieu (VNUHCM, Vietnam)
- Technical Assistant: Nguyen Hoang Quan-MSc (0938.551383)

Link google meet for online: <https://meet.google.com/uda-ejty-dkz>

Schedule	Name of invited speakers	Title of talks
13:00-13:15	<b>Invited talk 01. Assoc. Prof. Nguyen Van Toan</b> <i>Tohoku University, Japan</i>	Thermoelectric Generator with a High Integration Density for Portable and Wearable Self-Powered Electronic Devices
13:15-13:30	<b>Invited talk 02. Assoc. Prof. Nguyen Van Hieu</b> <i>Univeristy of Science, VNUHCM, Vietnam</i>	The review of Digital Microfluidics and Their Applications
13:30-13:45	<b>Invited talk 03. Asst. Prof. Vu The Dang</b> <i>Osaka Metropolitan University, Japan</i>	Experimental Studies on Spatial Resolution of a Delay-Line Current-Biased Kinetic-Inductance Detector
14:45-15:00	<b>Invited talk 04. Asst. Prof. Nguyen Tuan Hung (online)</b> <i>FRIIS, Tohoku University, Japan</i>	Entangling heat and charge in quantum material for thermoelectric application
15:00-15:15	<b>Oral 01. Dr. Le Duong Anh Duy</b> <i>GES, Saigon Hi-Teck Park, Vietnam</i>	Green synthesis of reduced-graphene oxide quantum dots and application for colorimetric biosensor

**Coffee break (15:15-15:30)**

## **Session 2. MEMS, Sensors and Ectronics Devices**

Room: C31, Building C, 227 Nguyen Van Cu Str., District 5, HCMC

- Chair: Assoc. Prof. Nguyen Van Toan (Tohoku University, Japan)
- Co-Chair: Assoc. Prof. Vo Minh Huan (HCMUTE, Vietnam)
- Technical Assistant: Nguyen Hoang Quan-MSc (0938.551383)

Link google meet for online: <https://meet.google.com/uda-ejty-dkz>

15:30-15:45	<b>Invited talk 05 . Dr. Dau Van (Online)</b> <i>Griffith University, Australia</i>	Electrohydrodynamic atomization (EHDA)
15:45-16:00	<b>Invited talk 06. Dr. Megat Muhammad Ikhsan Megat Hasnan (Online)</b> <i>Universiti Malaysia Sabah, Malaysia</i>	Deposition of high porous layer on TiO <sub>2</sub> rutile nanorod-flower surface using titanium RF post deposition and anodization process towards Dye-sensitize solar cell efficiency enhancement
16:00-16:15	<b>Invited talk 07. Asst. Prof. Tarlochan Singh (Online)</b> <i>Lovely Professional University, Jalandhar, India</i>	Developments in ECDM process during glass micromachining for MEMS packaging applications: process barriers and future opportunities
16:15-16:30	<b>Invited talk 08. Dr. Halubai Sekhar (Online)</b> <i>Nagoya Institute of Technology,</i>	Diamond wire wafer sawing technology: A way to reduce silicon kerf and wafer thickness for the

	<i>Japan</i>	applications of Si MEMS and solar cells
16:30-16:45	<b>Oral talk 02. Chuan Hui Ou-Ph.D student</b> Tohoku University, Japan	A Micromirror Driven by Electromagnetic Force for Fourier Transform Infrared Spectroscopy
16:45-17:00	<b>Oral talk 03 . Duong Ton Bao Phuc-Ph.D student</b> <i>University of Technology, VNUHCM, Vietnam</i>	A design TCADAS tool for semiconductor devices and case study of 65 nm conventional Floating-gate MOS transistor
17:00-17:15	<b>Oral talk 04 . Dang Cong Thinh-Ph.D student</b> <i>University of Technology, VNUHCM, Vietnam</i>	A simulated fabrication and characterization of a 65 nm floating-gate MOS transistor

### **Session 3. Microelectronics, IC design and Electronic Engineering**

Room: C32A, Building C, 227 Nguyen Van Cu Str., District 5, HCMC

- Chair: Prof. Kyeong-Sik Min (KMU& IKEEE, Korea)
- Co-Chair: Assoc. Prof. Hoang Trang (VNUHCM-UT, Vietnam)
- Technical Assistant: Nguyen Phuoc Hoang Khang (0918.035984)

Link google meet for online: <https://meet.google.com/wpw-acpy-anb>

13:00-13:15	<b>Invited talk 09 . Assoc. Prof. Hoang Trang</b> <i>University of Technology, VNUHCM, Vietnam</i>	An improvement of Tunnel Oxide thickness in the virtual fabrication process for a 65 nm Nanocrystal Floating-Gate MOS
13:15-13:30	<b>Invited talk 10. Asst. Prof. Min- Woo Kwon (online)</b> <i>Gangneung-Wonju National University, Korea</i>	Hybrid Neuron Circuit with Floating-body Positive Feedback Field Effect Transistor for Low Power operation
13:30-13:45	<b>Invited talk 11. Assoc. Prof. Vo Minh Huan</b> HCMUTE, Vietnam	Binary Memristor Crossbar Architecture based Neural Networks for Speech Recognition
14:45-15:00	<b>Invited talk 12. Assoc. Prof. Truong Ngoc Son</b> HCMUTE, Vietnam	Nanoscale Memristor Crossbar Array – A Potential Candidate for Neuromorphic Computing.
15:00-15:15	<b>Oral 05. Truong Tri Lac- PhD student</b> <i>University of Technology, VNUHCM, Vietnam</i>	Low power circuit design using NCL based asynchronous method

**Coffee break (15:15-15:30)**

### **Session 4. Material Sciences, Nano Technology and Related**

Room: C32B, Building C, 227 Nguyen Van Cu Str., District 5, HCMC

- Chair: Prof. Dinh Sy Hien (VNUHCM-US, Vietnam)
- Co-chair: Assoc. Prof. Nguyen Hoang Nam (University of Science, VNU Ha Noi, Vietnam)
- Technical Assistant: Nguyen Phuoc Hoang Khang (0918.035984)

Link google meet for online: <https://meet.google.com/wpw-acpy-anb>

15:30-15:45	<b>Invited talk 13. Prof. Dr. Dinh Sy Hien</b> <i>University of Science, VNUHCM, Vietnam</i>	Some results of NEMO-VN2, simulation program used for emerging nanoelectronic devices
15:45-16:00	<b>Invited talk 14. Assoc. Prof. Nguyen Hoang Nam</b> <i>University of Science, VNU Ha Noi, Vietnam</i>	Counting CD4+ T cells with microfluidic counter and functional nanoparticles
16:00-16:15	<b>Oral 06. Dr. Nguyen Van Men</b> <i>An Giang University, VNUHCM, Vietnam</i>	Coulomb drag in double-layer gapped graphene systems
16:15-16:30	<b>Oral 07. Dr. Nguyen Duy Vy</b> <i>Van Lang University, HCMC, Vietnam</i>	Tunable frequency of overhang-shaped cantilevers
16:30-16:45	<b>Oral 08. Nguyen Tuan Anh-MSc</b> <i>R&amp;D Center, SHTP, Vietnam</i>	Modified Graphene on SiC substrate by plasma treatment for sensing the nitrogen dioxide (NO <sub>2</sub> ) gas
16:45-17:00	<b>Oral 09. Nguyen Chi Cuong</b> <i>R&amp;D Center, SHTP, Vietnam</i>	A FEM analysis for novel micro-beam structure of high-stress sensitivity of SiC/Si MEMS pressure sensor

### **Session 5. Biomedical Materials, Biosensors, Medical devices and Related**

Room: C32B, Building C, 227 Nguyen Van Cu Str., District 5, HCMC

- Chair: Assoc.Prof. Huynh Chan Khon (VNUHCM-IU, Vietnam)
- Co-chair: Asst. Prof. Vu The Dang (Osaka Metropolitan University, Japan)
- Technical Assistant: Nguyen Ngoc Thao Nhi (0978.5029212)

Link google meet for online: <https://meet.google.com/wjy-oqos-qod>

13:00-13:15	<b>Invited talk 15. Assoc. Prof. Nguyen Thi Hiep</b> <i>International University, VNUHCM, Vietnam</i>	Natural polymer-based hydrogel bioinks for biomedical applications
13:15-13:30	<b>Invited talk 16. Dr. Cao Van Son</b> <b>(online)</b> <i>IFIRSE, Quy Nhon, Vietnam</i>	SiPM for proton beam monitors at J-PARC
13:30-13:45	<b>Invited talk 17. Assoc. Prof. Huynh Chan Khon</b> <i>International University, VNUHCM, Vietnam</i>	Low cost techniques for fabrication of point of care testing microfluidics in low-resource settings
14:45-15:00	<b>Oral 10 . Dr. Vo Hong Hai</b> <i>University of Science, VNUHCM, Vietnam</i>	Developing a remote online real-time system for radiation monitoring in a radiation therapy accelerator room.
15:00-15:15	<b>Oral 11. Huynh Quoc Viet, MSc</b> <i>University of Science, VNUHCM, Vietnam</i>	Survey on spiking neural network for feature extraction step to classify electroencephalogram signals
<b>Coffee break (15:15-15:30)</b>		
15:30-15:45	<b>Oral 12. Phan Thien Luan, MSc</b> <b>(online)</b>	Impedimetric based biorecognition element free microplastic identification with k-nearest-neighbor model

	<i>University of Science, VNUHCM, Vietnam and National Chung Hsing University- Taiwan</i>	
<b>4. MEETING OF PROGRAM COMMITTEE FOR 4thIWEMA2023</b>		
Time: 10:15-11:00 Room: C31, Building C, 227 Nguyen Van Cu Str., District 5, HCMC		
<ul style="list-style-type: none"> <li>. <i>Representative of VNUHCM-University of Science</i></li> <li>. <i>Representative of IEEE Vietnam Chapter</i></li> <li>. <i>Representative of IKEEE Korea</i></li> <li>. <i>Representative of HSIA Vietnam</i></li> <li>. <i>Some professors/researchers of VNUHCM (Science, Technology, Information Technology, International, nano,...) and Tohoku University (Japan), Griffith University (Australia),...</i></li> <li>. <i>Others</i></li> </ul>		
<b>5. Dinner party (18:00-21:00) at Phuc An Khang Restaurant (German Beer)</b> <i>(Departure at 17:45 by walk)</i>		

## \*2nd day of workshop (November 26, Saturday)

<i>Time</i>	<i>Title and Program</i>	<i>Contents and note</i>
08:00-08:15	Registration	Lobby of E.303 (Building E, 3 <sup>rd</sup> floor)
<b>1.TUTORIAL SESSION (for teaching assistants, students, engineers,...)</b>		
Room: E.303, Building 3, 3 <sup>rd</sup> Floor, 227 Nguyen Van Cu Str., District 5, HCMC		
<ul style="list-style-type: none"> <li>- <i>Chair: Prof. Nguyen Van Toan (Tohoku University)</i></li> <li>- <i>Co-chair: Dr. Doan Duc Chanh Tin (VNUHCM-Institute of Nanotechnology, Vietnam)</i></li> <li>- <i>Technical Assistant: Nguyen Hoang Quan-MSc and Ms. Nguyen Ngoc Thao Nhi</i></li> </ul>		
08:00-09:00	<b>Tutorial #1.</b> <b>Assoc.Prof. Nguyen Van Toan</b> <i>Tohoku University, Japan</i>	Metal-assisted chemical etching subjected to micro/nano devices <i>Công nghệ ăn mòn kim loại có hỗ trợ hóa học cho các linh kiện micro/nano</i>
09:00-10:00	<b>Tutorial # 2.</b> <b>Dr. Doan Duc Chanh Tin</b> <i>VNUHCM-Institute of Nanotechnology, Vietnam</i>	Introduce about VNUHCM-Institute of Nanotechnology and R&D achievements in the last 5 years. <i>Giới thiệu về Viện công nghệ Nano ĐHQG-HCM và các nghiên cứu, ứng dụng trong 5 năm gần đây.</i>
<b>2. LAB TOURS/ CITY TOURS : 13:00-16:00 (optional)</b>		

# The 3<sup>rd</sup> International Workshop on Engineering Physics, IC-MEMS-Sensors and Their Applications (3rdIWEMA2022)

November 25&26,2022; Ho Chi Minh City, Vietnam

*Host by Faculty of Physics – Engineering Physic, University of Science, VNUHCMC- Vietnam  
and Ono Lab, Graduate School of Engineering, Tohoku University, Japan*

## LIST OF TALKS AND RESEARCH GROUP FOR 3<sup>rd</sup> IWEMA2022

-----

No.	Speakers, participant	Nationality/ country, University	Departmen, lab, company	Session	Code	Title of talk	Email
<b>I. PLENARY SESSION: 04</b>							
- Time: 08:00-11:00AM, November 25th, 2022 (Friday);							
- Location: Building C, 227 Nguyen Van Cu Str., District 5, Ho Chi Minh City							
1	Prof. Dr. Takahito Ono	Tohoku Univ, Japan	Graduate of Engineering, Ono lab	Plenary C33	PL-01	Nanoengineered Microsystems IoT, Health and Environment Applications.	takahito.ono.d4@tohok u.ac.jp
2	Prof. Dr. Kyeong-Sik Min	Kook Min Univ, Korea	School of Engineering Science & IKEEE	Plenary C33	PL-02	Processing-in-memory for energy-efficient edge computing.	mks@kookmin.ac.kr
3	Prof. Dr. Congo Tak Shing Ching	National Chung Hsing Univ.,Taiwan	Biomedical Engineering	Plenary C33 <b>Online</b>	PL-03	Non-invasive diagnosis and measurement by electrical impedance spectroscopy	tsching@nchu.edu.tw

4	Prof. Dr. Dao Viet Dzung	Griffith University, Australia	Mechanical Engineering	Plenary C33 <a href="#">Online</a>	PL-04	MEMS Sensors for Industry and Smart Cities	d.dao@griffith.edu.au
---	--------------------------	--------------------------------	------------------------	---------------------------------------	-------	--	-----------------------

## II. PARALLEL SESSION:17

- Time: 13:00-17:00, November 25th, 2022 (Friday);

- Location: Building C, 227 Nguyen Van Cu Str., District 5, Ho Chi Minh City

<i>No.</i>	<i>1st author/speaker/participant</i>	<i>Nationality/country, University</i>	<i>Department, lab, company</i>	<i>Session</i>	<i>Code</i>	<i>Title of talk</i>	<i>Research group</i>
1	Assoc. Prof. Dr. Nguyen Van Toan	Tohoku University, Japan	Graduate of Engineering, Ono lab	Session1 Room C31	IN-01	Thermoelectric Generator with a High Integration Density for Portable and Wearable Self-Powered Electronic Devices	Nguyen Van Toan, Truong Thi Kim Tuoi, Nguyen Van Hieu, and Takahito Ono
2	Assoc. Prof. Dr. Nguyen Van Hieu	University of Science, VNUHCM	Physics and Electronic Engineering	Session1 Room C31	IN-02	The review of Digital Microfluidics and Their Applications	Nguyen Hoang Quan, Nguyen Ngoc Thao Nhi, Nguyen Hoang Long, Nguyen Chi Nhan, Ngo Yen Khanh, Ho Thanh Huy, Huynh Chan Khon and Nguyen Van Hieu
3	Asst. Prof. Vu The Dang	Osaka Metropolitan Univ., Japan	Quantum and Radiation Engineering,	Session1 Room C31	IN-03	Experimental Studies on Spatial Resolution of a Delay-Line Current-Biased Kinetic-Inductance Detector	The Dang Vu, Hiroaki Shishido, Kazuya Aizawa, Takayuki Oku, Kenichi Oikawa, Masahide Harada, Kenji M. Kojima, Shigeyuki Miyajima, Kazuhiko Soyama, Tomio Koyama, Mutsuo Hidaka, Soh Y. Suzuki, Manobu M.

							Tanaka, Masahiko Machida, Shuichi Kawamata and Takekazu Ishida
4	Asst. Prof. Nguyen Tuan Hung	Tohoku University, Sendai, Japan	Frontier Research Institute for Interdisciplin ary Sciences	Session1 Room C31 <a href="#">Online</a>	IN-04	Entangling heat and charge in quantum material for thermoelectric application	Nguyen Tuan Hung
5	Dr. Dau Van	Griffith Univ, Australia	Mechanical Engineering	Session 2 Room C31 <a href="#">Online</a>	IN-05	Electrohydrodynamic atomization (EHDA).	Dau Van
6	Dr. Megat Muhammad Ikhsan Megat Hasnan	Universiti Malaysia Sabah, Malaysia	Engineering	Session 2 Room C31 <a href="#">Online</a>	IN-06	Deposition of high porous layer on TiO <sub>2</sub> rutile nanorod-flower surface using titanium RF post deposition and anodization process towards Dye- sensitize solar cell efficiency enhancement	Megat Muhammad Ikhsan Megat Hasnan, Nafarizal Nayan, Mohd Khairul Ahmad, Zulkifli Azman and I.M. Noor
7	Asst. Prof. Tarlochan Singh	Lovely Professional University, Jalandhar, India	Product and Industrial Design Department	Session 2 Room C31 <a href="#">Online</a>	IN-07	Developments in ECDM process during glass micromachining for MEMS packaging applications: process barriers and future opportunities	Tarlochan Singh
8	Dr. Halubai Sekhar	Nagoya Institute of Technology, Japan	Super Photon ring8 (Spring8),	Session 2 Room C31 <a href="#">Online</a>	IN-08	Diamond wire wafer sawing technology: A way to reduce silicon kerf and wafer thickness for the applications of Si MEMS and solar cells	Halubai Sekhar

9	Assoc. Dr. Prof. Hoang Trang	University of Technology, VNUHCM	Electrical and Electronics Engineering	Session 3 Room C32A	IN-09	An improvement of Tunnel Oxide thickness in the virtual fabrication process for a 65 nm Nanocrystal Floating-Gate MOS	Thinh Dang Cong, Phuc Ton That Bao, Trang Hoang
10	Asst. Prof. Min-Woo Kwon	Gangneung-Wonju National University, Korea	Department of Electric Engineering	Session 3 Room C32A <a href="#">Online</a>	IN-10	Hybrid Neuron Circuit with Floating-body Positive Feedback Field Effect Transistor for Low Power operation	Asst. Prof. Min-Woo Kwon
11	Assoc. Prof. Dr. Vo Minh Huan	Ho Chi Minh University of Technology and Education	Electrical and Electronics Engineering	Session 3 Room C32A	IN-11	Binary memristor crossbar architecture based neural networks for speech recognition	Assoc. Prof. Dr. Vo Minh Huan
12	Assoc. Prof. Dr. Truong Ngoc son	Ho Chi Minh University of Technology and Education	Electrical and Electronics Engineering	Session 3 Room C32A	IN-12	Nanoscale Memristor Crossbar Array – A Potential Candidate for Neuromorphic Computing.	Truong Ngoc Son and Le Minh.
13	Prof. Dr. Dinh Sy Hien	University of Science, VNUHCM, Vietnam	Electronics and Telecommunications	Session 4 Room C32B	IN-13	Some results of NEMO-VN2, simulation program used for emerging nanoelectronic devices	Prof. Dr. Dinh Sy Hien
14	Assoc. Prof. Dr. Nguyen Hoang Nam	University of Science, VNU Ha Noi Vietnam	Engineering Physics	Session 4 Room C32B	IN-14	Counting CD4+ T cells with microfluidic counter and functional nanoparticles	Nguyen Hoang Nam, Do Quang Loc, Phi Thi Huong, Luu Manh Quynh, Pham Thi Thu Huong, Nguyen Thi Van Anh, Bui Thanh Tung, Chu Duc Trinh, Nguyen Hoang Luong
15	Assoc. Prof. Dr Nguyen Thi Hiep	International University, VNU HCM, Vietnam	Biomedical Engineering	Session 5 Room C32B	IN-15	Natural polymer-based hydrogel bioinks for biomedical applications	Assoc. Prof. Dr Nguyen Thi Hiep

16	Dr. Cao Van Son	Quy Nhon, Vietnam	The Institute for Interdisciplinary Research in Science and Education	Session 5 Room C32B	IN-16	SiPM for proton beam monitors at J-PARC	Dr. Cao Van Son
17	Dr. Huynh Chan Khon	VNUHCM-IU, Vietnam	Biomedical Engineering	Session 5 Room C32B	IN-17	Low cost techniques for fabrication of point of care testing microfluidics in low-resource settings	Dr. Huynh Chan Khon

### III. ORAL PRESENTATIONS:12

<i>No.</i>	<i>1st author/speaker/participant</i>	<i>Nationality/country, University</i>	<i>Department, lab, company</i>	<i>Session</i>	<i>Code</i>	<i>Title of talk</i>	<i>Research group</i>
1	Dr. Le Duong Anh Duy	Saigon Hi-tech Park (SHTP), Vietnam	GES	Session 1 Room C31	OR-01	Green synthesis of reduced-graphene oxide quantum dots and application for colorimetric biosensor	Le Duong Anh Duy and Kim Jeayong.
2	Ou Chuan Hui- PhD student	Tohoku University	Graduate of Engineering, Ono lab	Session 2 Room C31	OR-02	A Micromirror Driven by Electromagnetic Force for Fourier Transform Infrared Spectroscopy	Chuan-Hui Ou, Nguyen Van Toan and Takahito Ono
3	Ton That Bao Phuc-PhD student	University of Technology, VNUHCM, Vietnam	Electrical and Electronics Engineering	Session 2 Room C31	OR-03	A design TCADAS tool for semiconductor devices and case study of 65 nm conventional Floating-gate MOS transistor	Dang Cong Thinh, Ton That Bao Phuc and Hoang Trang
4	Dang Cong Thinh-PhD student	University of Technology, VNUHCM, Vietnam	Electrical and Electronics Engineering	Session 2 Room C31	OR-04	A simulated fabrication and characterization of a 65 nm floating-gate MOS transistor	Dang Cong Thinh, Ton That Bao Phuc and Hoang Trang

5	Truong Tri Lac- PhD studen	University of Technology, VNUHCM, Vietnam	Electrical and Electronics Engineering	Session 3 Room C32A	OR-05	Low power circuit design using NCL based asynchronous method	Truong Tri Lac, Le Thanh Toi and Hoang Trang
6	Dr. Nguyen Van Men	An Giang University, VNUHCM	Physics	Session 4 Room C32B	OR-06	Coulomb drag in double- layer gapped graphene systems	Dong Thi Kim Phuong and Nguyen Van Men
7	Dr. Nguyen Duy Vy	Van Lang University, Ho Chi Minh City, Vietnam	Faculty of Technology	Session 4 Room C32B	OR-07	Tunable frequency of overhang-shaped cantilevers	Le Tri Dat, Nguyen Duy Vy and Amir F. Payam
8	Nguyen Tuan Anh-MSc	Saigon-Hi-Tech Park, Vietnam	R&D Center	Session 4 Room C32B	OR-08	Modified Graphene on SiC substrate by plasma treatment for sensing the nitrogen dioxide (NO <sub>2</sub> ) gas	Ly Truong Huu, Hoai Duy Tran, Phuong Thanh Nguyen, Tuan Minh Dao, Tuan Quoc Dang, Doanh Tu Tieu, Tham Thi Hong Nguyen, Anh Tuan Nguyen, Thanh Vo Ke Ngo, Tuyet-Mai Tran- Thuy
9	Dr. Nguyen Chi Cuong	Saigon-Hi-Tech Park, Vietnam	R&D Center	Session 4 Room C32B	OR-09	A FEM analysis for novel micro-beam structure of high-stress sensitivity of SiC/Si MEMS pressure sensor	Nguyen Chi Cuong, Braidon Tong, Tuan- Hung Nguyen, Hong- Quan Nguyen, Tuan- Khoa Nguyen, Thanh Nguyen, Toan Dinh, Ngo Vo Ke Thanh, Truong Huu Ly, Hoang Ba Cuong, Trinh Xuan Thang, Van Thanh Dau, Dzung Viet Dao

10	Dr. Vo Hong Hai	University of Science, VNUHCM, Vietnam	Nuclear Physics Engineering	Session 5 Room C32B	OR-10	Developing a remote online real-time system for radiation monitoring in a radiation therapy accelerator room.	Dr. Vo Hong Hai
11	Huynh Quoc Viet-MSc	University of Science, VNUHCM, Vietnam	Physcis - Engineering Physics	Session 5 Room C32B	OR-11	Survey on spiking neural network for feature extraction step to classify electroencephalogram signals	Huynh Viet Quoc and Huynh Van Tuan
12	Phan Thien Luan-MSc	University of Science, VNUHCM, Vietnam	Physcis - Engineering Physics	Session 5 Room C32B	OR-12	Impedimetric based biorecognition element free microplastic identification with k-nearest-neighbor model	Phan Thien Luan-MSc

#### **IV. POSTER PRESENTATIONS:08**

<i>No.</i>	<i>1st author/speaker/participant</i>	<i>Nationality/country, University</i>	<i>Department, lab, company</i>	<i>Session</i>	<i>Code</i>	<i>Title of poster</i>	<i>Research group</i>
1	Ngo Yen Khanh	International University, VNUHCM	Biomedical Engineering	Poster	PO-01	Development of a Digital Microfluidics system for point-of-care molecular diagnostics.	Ngo Yen Khanh, Tuan Hoang, Thien Hoang, Nguyen Van Hieu and Huynh Chan Khon
2	Nguyen Hoang Quan	University of Science, VNUHCM	Physics and Electronic Engineering	Poster	PO-02	The study of lithography parameters for the fabricating process of nMOS electrodes	Nguyen Hoang Quan, Truong Hai Yen, Ho Thanh Huy, Tran Thi Huynh Giao and Nguyen Van Hieu
3	Nguyen Phuoc Hoang Khang	University of Science, VNUHCM	Physics and Electronic Engineering	Poster	PO-03	Application of deep learning in fault detection using thermal image for Photovoltaic panel.	Nguyen Phuoc Hoang Khang, Trieu Thien Khang and Nguyen Chi Nhan

4	Tran Hoang Nhut	University of Science, VNUHCM	Physics and Electronic Engineering	Poster	PO-04	IoT System for Aquaponics garden with vegetables and fishes	Tran Hoang Nhut, Ho Thanh Huy, Nguyen Chi Nhan and Nguyen Van Hieu
5	Nguyen Hoang Long	University of Science, VNUHCM	Physics and Electronic Engineering	Poster	PO-05	SERS Sensor based on Ag Nanoparticles for fast detection of fast GREEN FCF	Nguyen Hoang Long, Nguyen Huu Ke and Le Vu Tuan Hung
6	Ha Minh Khue	University of Science, VNUHCM	Physics and Electronic Engineering	Poster	PO-06	Design and implementation fo Doppler radar system target classification using deep learning	Ha Minh Khue, Nguyen Duc Hoang Ha, Nguyen Hoang Quan and Nguyen Chi Nhan
7	Tran Thien Minh	University of Science, VNUHCM	Physics and Electronic Engineering	Poster	PO-07	The equipment for testing food 's quality using the image by machine learning.	Tran Thien Minh, Nguyen Hoang Quan, Le Hong Nhung and Nguyen Van Hieu
8	Le Hong Nhung	University of Science, VNUHCM	Physics and Electronic Engineering	Poster	PO-08	Checking diseases through cantaloupe leaves using Convolutional Neural Network (CNN) Algorithm	Le Hong Nhung, Tran Thien Minh, Ho Thanh Huy, Tran Quoc Phong and Nguyen Van Hieu

*HCM City, Nov 20, 2022*

**On behalf of Organizer of 3rd IWEMA2022**

**Program Chair**

**Assoc. Prof. Huynh Van TUAN**

*(Dean Faculty of Physics – Engineering Physics, VNUHCM-US)*

*Email: 3iwema2022@gmail.com*

# 1.

# PLENARY SESSION

Venue: University of Science, VNUHCM  
*227 Nguyen Van Cu Str., District 5, Ho Chi Minh city,  
Vietnam*

The 3<sup>rd</sup> International Workshop on Engineering Physics, IC-MEMS-Sensors and  
Their Applications (3<sup>rd</sup>IWEMA2022)  
November-25&26,2022; Ho Chi Minh City, Vietnam

*Host by Faculty of Physics- Engineering Physic, University of Science ,  
Vietnam National University- HCMC)  
and Ono Lab, Tohoku University, Sendai, Japan*

**PLENARY SESSION (Code: PL-01)**

-----

**1.About speaker**

Title of talk: **Nanoengineered Microsystems IoT, Health and Environment Applications.**

Author (s): Takahito Ono

Institution (s): Ono laboratory, Graduate School of Engineering, Tohoku University

Country: Japan

Speaker: Takahito Ono

Academic title: Professor, Doctoral Engineering.

E-mail: takahito.ono.d4@tohoku.ac.jp

Handphone: +81-90-6450-3324/

**2.Abstract**

Nanotechnology-based microstructures, functional materials, and mechanical structures can be used to make microsystems with high performance and functionality, high sensitivity, or low power consumption, and several examples will be presented. By detecting slight mechanical displacements, highly sensitive and multifunctional sensors are possible, and we are attempting to apply them to molecular recognition sensors, as shown in Fig. 1 [1] and health care devices as shown in Fig. 2[2]. In addition, by adding nanomaterials in the manufacturing process of microsystems, high-performance functional materials can be created, and highly sensitive thermoelectric devices and their applied systems are being developed [3]. By forming highly reactive nanocatalysts, it is possible to create compact systems that reduce gases with a high efficiency.

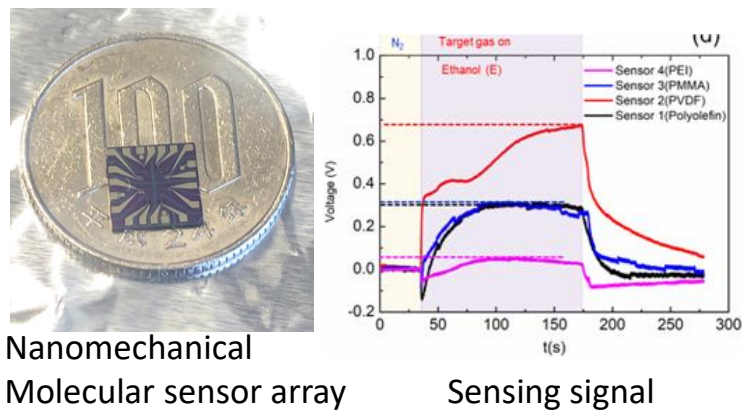

Fig. 1. Nanomechanical molecular sensor array (left figure) and the sensing signals of volatile organic vapor.

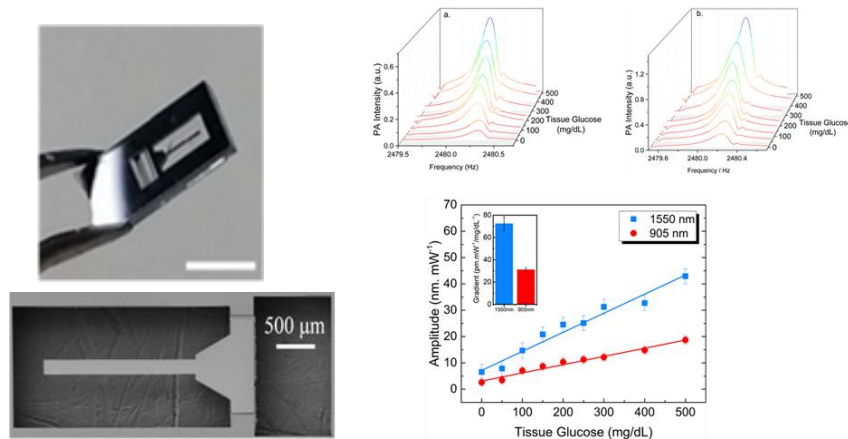

Fig. 2. Resonant sensors for photoacoustic sensor, and the detection signal of glucose with two laser diodes.

Keywords: Microsystems, Nanoengineering, Sensors, Thermoelectric power generators, Power Conversion.

References:

- [1] Masaya Toda, Krzysztof Moorthi, Takumi Hokama, Zhuqing Wang, Mai Yamazaki, Takahito Ono, Miniature piezoresistive sensor for detecting volatile organic components, *Sensors and Actuators, B:Chemical* 333,(2021) 129524.
- [2] Imran Latif, Masaya Toda, Takahito Ono, Hermetically Packaged Microsensor for Quality Factor-Enhanced Photoacoustic Biosensing. *Photoacoustics* 18, (2020) 100189.
- [3] T. T. K. Tuoi, N. V. Toan, T. Ono, Self-powered wireless sensing system driven by daily ambient temperature energy harvesting, *Applied Energy* 311, (2022)118679.

### 3. Short- Biography

**Full name:**

Takahito Ono

Date of Birth: July 12, 1967

**Position:**

Dr. Engineering

Professor, Graduate School of Engineering, Tohoku University

Professor, Micro System Integration Center, Tohoku University

**Address**

Department of Mechanical Systems and Design, Graduate School of Engineering, Tohoku University,

6-6-01 zaAoba, Aramaki, Aoba-ku, Sendai 980-8579, Japan

-Telephone/Fax : +81-22-795-5806 / +81-22-795-5808

- Email: takahito.ono.d4@tohoku.ac.jp

**Home page:** [http://www.nme.mech.tohoku.ac.jp/index\\_e.html](http://www.nme.mech.tohoku.ac.jp/index_e.html)

**Education and Carrier**

Takahito Ono was born in Hokkaido, Japan. He received the B.S. degree in physic from Hirosaki University, Japan, in 1990 and the M.S. degree in physics from Tohoku University, Japan. He received the D.E. degree in mechatronics and precision engineering from Tohoku University in 1996. During 1996–1999, he has been a Research Associate in the Department of Mechatronics and Precision Engineering, Tohoku University. During 1999-2009, he has been an Associate Professor.

He is currently a Professor at Department of Mechanical Systems Engineering in Tohoku University. Also he was a professor of Department of Mechanical Engineering, Graduate School of Engineering at The University of Tokyo during 2013-2016. He was director of Micro/Nanomachining education center, Tohoku University during 2012-2014. He is the vice-director of The Micro System Integration Center, Tohoku University. He was the director of The Micro System Integration Center, Tohoku University during 2017-2021.

His expertise is in the area of IoT sensors and applications including microelectromechanical systems (MEMSs), nanoelectromechanical systems (NEMSSs), silicon-based nanofabrication, ultra-sensitive sensing based on resonating device, devices for nanoscale science and engineering. Recent interests cover nanomaterials and their integration into the microsystems for applications of IoT sensors, environment monitoring, biomedical sensors, nano-energy, and scientific instrumentation.

He teaches graduate and undergraduate courses on nanomechanics, MEMS, nanomaterials. He is a member of The Institute of Electrical and Electronics Engineer (IEEE), fellow of The Institute of Electrical Engineers of Japan (IEEJ), fellow of ElectroChemical Society (ECS), member of the Japan Society of Applied Physics (JSAP), and member of The Japan Society for Precision Engineering (JSPE). He was the editor in chief of IEEJ Transactions on Sensors and Micromachines. Currently, He is an adviser of Japanese Science Technology (JST). He received Tokin Research Award from Tokin Science Foundation for the development of nanomechanical machines on 2005, also received MNC 2012 Paper Award, 15<sup>th</sup> International Microprocess and Nanotechnology Conference etc., IEEJ award 2022, He has published over 290 refereed original papers.

**Publications (1993-2022) :** 295 papers in international journal (ISI, SCIE, Scopus, WoS,...).

The 3<sup>rd</sup> International Workshop on Engineering Physics, IC-MEMS-Sensors and  
Their Applications (3<sup>rd</sup>IWEMA2022)  
November-25&26,2022; Ho Chi Minh City, Vietnam

*Host by Faculty of Physics- Engineering Physic, University of Science ,  
Vietnam National University- HCMC)  
and Ono Lab, Tohoku University, Sendai, Japan*

**PLENARY SESSION (Code: PL-02)**

-----

**1.About speaker**

Title of talk: **Processing-in-memory for energy-efficient edge computing**

Author (s):Kyeong-Sik Min

Institution (s): Kookmin University

Country: Korea

Speaker: Kyeong-Sik Min

Academic title: Professor

E-mail: mks@kookmin.ac.kr Handphone: +82-10-5699-8310

**2.Abstract**

A large number of sensors and edge devices will be required in the coming Internet-of-Things (IoT) era to make human life more comfortable and safe. These numerous sensors and edge devices can collect massive amounts of unstructured data from both human society and nature. If we send all of the sensed data to cloud servers in data centers, the energy consumed in cloud computing and data communication can skyrocket to unacceptable level, necessitating massive amounts of electrical energy generation. To mitigate the energy crisis caused by cloud computing and data communication, we can consider processing-in-memory for computing at or near the edge, as well as IoT sensors, where data communication to servers can be significantly reduced [1], [2]. Furthermore, because the edge computing by processing-in-memory does not rely on energy-wasting Von Neumann computing architecture, it can be extremely beneficial in terms of computing energy savings. This talk

explains and discusses various emerging memories and their crossbars, such as memristor crossbars, as a viable candidate for realizing future energy-efficient edge intelligence [1], [2].

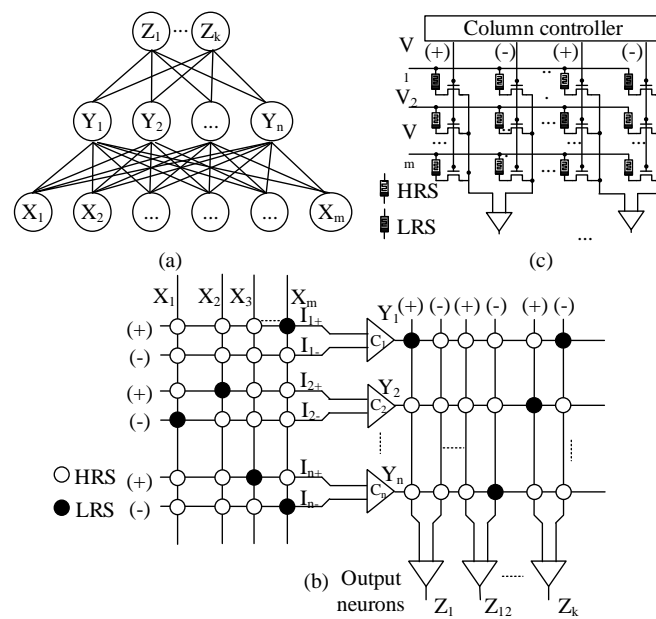

Fig.1 The block diagram of 2-layer artificial neural networks with input, hidden, and output neurons (b) The memristor crossbars for implementing 2-layer artificial neural networks (c) The detailed schematic of the memristor crossbar with 1Transistor-1Memristor cell [1]

\*Keywords: processing-in-memory, energy-efficient edge computing, memristor crossbars, internet-of-things, edge intelligence.

\*References:

[1] Tien Van Nguyen, Jiyong An, Seokjin Oh, Son Ngoc Truong, and Kyeong-Sik Min, "Quantization, training, parasitic resistance correction, and programming techniques of memristor-crossbar neural networks for edge intelligence," *Neuromorphic Computing and Engineering (NCE)*, 2, Jul. 7, 2022.

[2] Jiyong An, Seokjin Oh, Tien Van Nguyen, and Kyeong-Sik Min, "Synapse-Neuron-Aware Training Scheme of Defect-Tolerant Neural Networks with Defective Memristor Crossbars," *Micromachines*, 13(2), 273, Feb. 8, 2022.

### 3. Short- Biography

**Full name:** Kyeong-Sik MIN, Ph.D.

**Academic title:** Professor

**Institute:** School of Electrical Engineering, Kookmin University, Seoul, Korea

**Contacts:**

Email: mks@kookmin.ac.kr

Handphone: (+82)-10-5699-8310



**Research Areas:**

- Semiconductor circuits and systems

- Memory and analog circuits
- Neuromorphic and processing-in-memory circuits

## **2. Position (Faculty/Department/Laboratory)**

- School of Electrical Engineering
- Integrated Systems Lab.

## **3. Research Activities**

1. President of Institute of Korean Electrical and Electronics Engineers (IKEEE), 2022
2. Chairperson of SoC Research Division, in IEIE, 2021
3. Technical program committee, Asian Solid-state Circuits Conference (A-SSCC), 2010, 2011, 2012, 2013
4. Reviewer committee, International Symposium on Circuits and Systems (ISCAS), 2012, 2015, 2017, 2019, 2020, 2021
5. Technical program committee, Korean Conference on Semiconductors, 2013, 2014, 2015, 2016, 2017, 2018, 2019, 2020, 2021, 2022
6. Organizing committee, International SoC Design Conference (ISOCC), 2013, 2014, 2015, 2016, 2017, 2018, 2019, 2020, 2021, 2022
7. Organizing committee, IEEE International AI Circuits and Systems Conference (AICAS), Incheon, 2022
8. Co-organizer, Workshop on Memristor-based Systems for Neuromorphic Applications, Turin in Italy, Sep. 2013
9. Special-session organizer and special-session chair, International Workshop on Cellular Nanoscale Networks and their Applications (CNNA), Notre Dame, IN, July 2014
10. Special-session organizer and special-session chair, International Symposium on Circuits and Systems (ISCAS), Lisbon, 2015 (Session title: Memristor-based cellular nanoscale networks: theory, circuits, and applications)
11. Special-session organizer and special-session chair, International SoC Design Conference (ISOCC), 2015, 2016, 2017, 2018, 2019, 2020, 2021, 2022
12. Session chair, Collaborative Conference on 3D & Materials Research (CC3DMR), Busan in Korea, June 2015
13. Editor in Chief, Journal of Institute of Korean Electrical and Electronics Engineers, 2016, 2017
14. Organizer of the tutorial lecture, Neuromorphic hardware for future artificial intelligence, IKEEE, 2016, 2017, 2018, 2019
15. Tutorial lecturer, International Symposium at Circuits and Systems (ISCAS), Baltimore, MD, May 2017 (Tutorial title: Memristor-CMOS hybrid circuits and systems for brain-inspired computing)
16. Invited speaker, International Conference on Electronic Materials and Nanotechnology for Green Environment (ENGE), 2014, 2018
17. Organizing committee, Collaborative Conference on Materials Research (CCMR), 2017, 2018, 2019
18. Nanoelectronics and gigascale systems technical committee, IEEE Circuits & Systems Society, 2017, 2018, 2019, 2020, 2021, 2022
19. Tutorial lecturer, IEIE summer conference, Jeju in Korea, July 2018 (Tutorial title: Memristor Neural Networks for Brain-Inspired Cognitive Computing: From Ideal to Reality)
20. Workshop organizer and speaker, Design, automation and test in Europe (DATE), 2019, Florence, Italy (Workshop title: Recent Trends in Memristor Science & Technology: The Journey from Single Memristor Device towards 100 Trillion Synapses of Brain)
21. Special-session organizer and special-session chair, International Symposium on Circuits and Systems (ISCAS), Sapporo, 2019 (Session title: Nonlinear, Self-Oscillatory, and Hybrid Circuits for Bio-Mimicking Neural Networks and Machine Learning Systems)
22. Technical program committee, International Conference on ASIC (ASICON), 2019
23. Tutorial lecturer, IEIE summer conference, Jeju in Korea, June 2019 (Tutorial title: Recent Trends in Memristor Science & Technology: The Journey from Single Memristor Device towards 100 Trillion Synapses of Brain)

24. Program organizer (Topic: High performance semiconductor), International Conference on Electronic Materials and Nanotechnology for Green Environment (ENGE), 2020
25. Associate Editor, Journal of Semiconductor Technology and Science, 2020, 2021, 2022
26. Editorial board member, Neuromorphic Computing and Engineering, IOP publishing, 2020, 2021, 2022
27. Special topic editor, “Memristor computing for neuromorphic systems,” Frontiers in computational neuroscience, 2020
28. Special-session chair, International Symposium on Circuits and Systems (ISCAS), Daegu, 2021
29. Special-session chair, IEEE International AI Circuits and Systems Conference (AICAS), Incheon, 2022

### **Research Achievements and Awards:**

#### *Books*

1. Young-Su Kim, SangHak Shin, Jacopo Secco, Kyeong-Sik Min, and Fernando Corinto, “Memristor-based platforms: A comparison between continuous-time and discrete-time cellular neural networks,” book chapter, Advances in Neuromorphic Hardware using Emerging Nanodevices, Springer, Inc., 2017, ISBN 978-81-322-3701-3.
2. Fernando Corinto, Alon Ascoli, Young-Su Kim, and Kyeong-Sik Min, “Cellular nonlinear network with memristor synapses,” book chapter, Memristor Networks, Springer, Inc., 2014, ISBN 978-3-319-02629-9, pp. 267-292.

#### *Research Awards*

1. Grand Prize in Haedong Best Paper Award, IEIE, Journal of Semiconductor Technology and Science (JSTS), 2020
2. Academic Achievement Award, Institute of Korean Electrical and Electronics Engineers, Korea, 2015
3. Distinguished Service Award, Institute of Korean Electrical and Electronics Engineers, Korea, 2014
4. Chip Design Contest Award at Korean Conference on Semiconductors, 2012
5. CAD & Design Methodology Award at Korean Conference on Semiconductors, 2011
6. Chip Design Contest Award at Korean Conference on Semiconductors, 2011
7. Distinguished Service Award, Institute of Electronics and Information Engineers, Korea, 2011

### **ISI Selected Publications (2014-now)**

- [1]. Tien Van Nguyen, Jiyong An, Seokjin Oh, Son Ngoc Truong, and Kyeong-Sik Min, “Quantization, training, parasitic resistance correction, and programming techniques of memristor-crossbar neural networks for edge intelligence,” Neuromorphic Computing and Engineering, 2 032001, 2022.
- [2]. Tien Van Nguyen, Khoa Van Pham, and Kyeong-Sik Min, “Memristor-CMOS Hybrid Circuit for Temporal-Pooling of Sensory and Hippocampal Responses of Cortical Neurons,” Materials, 12(6), 875, March 2019.
- [3]. Son Ngoc Truong, Khoa Van Pham, and Kyeong-Sik Min, “Spatial-Pooling Memristor Crossbar Converting Sensory Information to Sparse Distributed Representation of Cortical Neurons,” IEEE Transactions on Nanotechnology, vol. 17, iss. 3, pp. 482 – 491, May 2018.
- [4]. Son Ngoc Truong, Khoa Van Pham, Wonsun Yang, and Kyeong-Sik Min, “Sequential memristor crossbar for neuromorphic pattern recognition,” IEEE Transactions on Nanotechnology, vol. 15, iss. 6, pp. 922– 930, Nov. 2016.
- [5]. Son Ngoc Truong, SangHak Shin, Sang-Don Byeon, Jaesang Song, and Kyeong-Sik Min, “New twin crossbar architecture of binary memristors for low-power image recognition with discrete cosine transform,” IEEE Transactions on Nanotechnology, vol. 14 , issue 6, pp. 1104-1111, Nov. 2015.
- [6]. Son Ngoc Truong, Seok-Jin Ham, and Kyeong-Sik Min, “Neuromorphic crossbar circuit with nanoscale filamentary-switching binary memristors for speech recognition,” Nanoscale Research Letters, vol. 9:629, Nov. 2014.

### **Invited talks**

- [1]. Seokjin Oh, Jiyong An, and Kyeong-sik Min, "Circuit and Training Techniques Compensating for Non-Ideal Effects in Memristor Neural Networks," International Conference on Solid-State & Integrated Circuit Technology (ICSICT), Nanjing in China, Oct. 25. 2022.
- [2]. Tien Van Nguyen, Jiyong An, Seokjin Oh, and Kyeong-Sik Min, "Training, Programming, and Correction Techniques of Memristor Crossbar Neural Networks with Non-Ideal Effects such as Defects, Variation, and Parasitic Resistance," International Conference on ASIC (ASICON), Kunming in China, Oct. 26. 2021.
- [3]. Khoa Van Pham, Tien Van Nguyen, and Kyeong-Sik Min, "Defect-Tolerant and Energy-Efficient Training of Multi-Valued and Binary Memristor Crossbars for Near-Sensor Cognitive Computing," International Conference on ASIC (ASICON), Chongqing, China, Nov. 2019.
- [4]. Kyeong-Sik Min, "Memristor-crossbar-based neural networks: from ideal to reality," Special topic's workshop at International Conference on Design, Automation & Test in Europe (DATE) 2019, Florence in Italy, Mar. 2019.
- [5]. Kyeong-Sik Min, "Memristor Neural Networks: From Ideal to Reality," International Conference on Electronic Materials and Nanotechnology for Green Environment (ENGE 2018), Nov. 2018.
- [6]. Kyeong-Sik Min, "Memristor Neural Networks for Mimicking Brain's Neural Architecture and Processing," Fall Conference of Korean Physical Society, Oct. 2018.
- [7]. Son Ngoc Truong and Kyeong-Sik Min, "Memristor-CMOS Hybrid Circuits for Brain-Mimicking Computing," Collaborative Conference on Materials Research (CCMR), Korea, June 2017.
- [8]. Kyeong-Sik Min, "Memristor-based neuromorphic crossbar circuits," the 10th Scientific Conference, Hochiminh, Vietnam, Nov. 2016.
- Kyeong-Sik Min, "Neuromorphic crossbar circuits of memristors," Korean Conference on Semiconductors (KCS), Feb. 2016.
- [9]. Son Ngoc Truong, SangHak Shin, Jeasang Song, Hyun-Sun Mo, Daejeong Kim, and Kyeong-Sik Min, "Neuromorphic Crossbars of Memristor Synapses," 5th Non-Volatile Memory Technology Symposium (NVMTS), Beijing in China, Oct. 2015.
- [1]. Son Ngoc Truong, SangHak Shin, Jeasang Song, Hyun-Sun Mo, Daejeong Kim, and Kyeong-Sik Min, "Memristor Crossbar Circuits," 10th SICC International Tutorial Workshop Nonlinear Dynamics in Computational Neuroscience: from Physics and Biology to ICT, Turin in Italy, Sep. 2015.
- [11]. Son Ngoc Truong, SangHak Shin, Jeasang Song, Hyun-Sun Mo, and Kyeong-Sik Min, "Efficient training of nano-scale memristors for synaptic plasticity," Collaborative Conference on 3D & Materials Research (CCMR), pp. 236-237, Busan in Korea, June 2015.
- [12]. Son Ngoc Truong, SangHak Shin, Sang-Don Byeon, JeaSang Song, Hyun-Sun Mo, and Kyeong-Sik Min, "Nanoscale memristor-based crossbar memories for neuromorphic applications," EMN EAST Meeting (Energy Materials Nanotechnology), Beijing, China, April 2015.
- [13]. Son Ngoc Truong and Kyeong-Sik Min, "Nano-scale memristor crossbar array for neuromorphic applications" International Conference on Electronic Materials and Nanotechnology for Green Environment (ENGE), Jeju in Korea, Nov. 2014.
- [14]. Kyeong-Sik Min, "Low-leakage techniques for leakage-dominant VLSI," 3rd Annual World Congress of Emerging InfoTech, Dalian in China, June 2014.
- [15]. Kyeong-Sik Min, "Memristor crossbar array circuits for neuromorphic applications," Special topic's workshop at International Conference on Design, Automation & Test in Europe (DATE) 2014, Dresden in Germany, Mar. 2014.
- [16]. Kyeong-Sik Min, "Memristor circuits for neuromorphic systems," Workshop on Memristor-based Systems for Neuromorphic Applications, Turin in Italy, Sep. 2013.
- [17]. Huan Minh Vo, Jeong Heon Kim, Jun Myung Choi, Young Su Kim, Seok Jin Ham, and Kyeong-Sik Min, "Memristor-CMOS hybrid integrated circuits for memory, digital, and neuromorphic applications," Solid-State Systems Symposium, Hochiminh in Vietnam, pp. 243-248, Aug. 2012.

The 3<sup>rd</sup> International Workshop on Engineering Physics, IC-MEMS-Sensors and  
Their Applications (3<sup>rd</sup>IWEMA2022)  
*November-25&26,2022; Ho Chi Minh City, Vietnam*

*Host by Faculty of Physics- Engineering Physic, University of Science ,  
Vietnam National University- HCMC)  
and Ono Lab, Tohoku University, Sendai, Japan*

**PLENARY SESSION (Code: PL-03)**

-----

**1.About speaker**

Title of talk: **Non-invasive diagnosis and measurement by electrical impedance spectroscopy**

Author (s): Congo Tak Shing Ching

Institution (s): National Chung Hsing University

Country: Taiwan

Speaker: Congo Tak Shing Ching

Academic title: Professor, PhD.,

E-mail: [tsching@nchu.edu.tw](mailto:tsching@nchu.edu.tw) Handphone: +886-989572005

**2. Abstract**

In our days impedance is significant not only in our daily life but also in medical diagnostics. Medical communities have successfully applied it to the non-invasive diagnostics of various conditions of the human body. The intention of developing non-invasive medical diagnostics (NIMD) is to facilitate the early detection, diagnosis, and treatment of diseases. The early diagnosis and treatment of many diseases, including cancers, is critical not only for prolonging and improving the quality of life but also for reducing medical costs. NIMD can be defined as those methods used to examine the human body without invading the integrity of the body. There are lots of NIMD, like ultrasonic diagnostics, infrared diagnostics and etc, but this speech will not discuss with them. The speaker cites his own research experiences in applying electrical impedance spectroscopy in NIMD. Strictly speaking, this speech will introduce the application of bioimpedance for tissue characterization, like cancerous tissue.

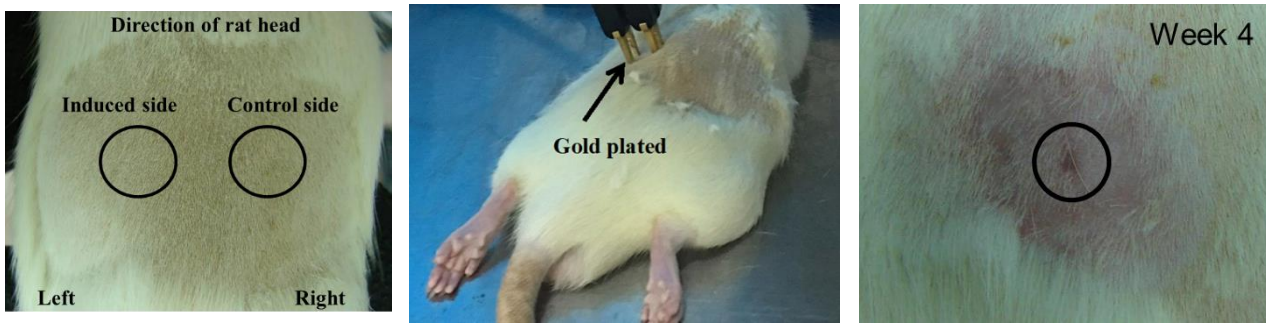

**Fig.1:** Bioimpedance measurement for rat skin inflammation.

\*Keywords: Non-invasive, diagnosis, electrical impedance spectroscopy, tissue

\*References:

- [1] Thien Luan Phan, Nguyen Van Hieu, Tzong Shiun Li, Ko-Chang Tsao and Congo Tak Shing Ching. Noninvasive and real-time in vivo characterization of Inflammation skin. *Skin Research and Technology* 2021; 00: 1-8.
- [2] Congo Tak-Shing Ching and Jhih-Hao Chen. An Non-invasive, Bioimpedance-based 2-Dimensional Imaging System for Detection and Localization of Pathological Epithelial Tissues. *Sensors and Actuators B: Chemical* 2015; 206: 319–326
- [3] Tai-Ping Sun, Congo Tak-Shing Ching, Chi-Sheng Cheng, Su-Hua Huang, Yi-Juai Chen, Chin-Sung Hsiao, Ching-Haur Chang, Shiow-Yuan Huang, Hsiu-Li Shieh, Wei-Hao Liu, Chia-Ming Liu and Chung-Yuan Chen. The use of bioimpedance in the detection/screening of tongue cancer. *Cancer Epidemiology* 2010; 34: 207-211
- [4] Congo Tak-Shing Ching, Tai-Ping Sun, Su-Hua Huang, Chin-Sung Hsiao, Ching-Haur Chang, Shiow-Yuan Huang, Yi-Juai Chen, Chi-Sheng Cheng, Hsiu-Li Shieh and Chung-Yuan Chen. A Preliminary Study of the Use of Bioimpedance in the Screening of Squamous Tongue Cancer. *International Journal of Nanomedicine* 2010; 5: 213-220
- [5] Tak-Shing Ching, Tai-Ping Sun, Wei-Hao Liu. System and data processing device for bioimpedance analysis. Taiwan patent filed: I445951, issued date: 21 July 2014.

### 3. Short- Biography

**Full name:** Congo Tak Shing Ching, PhD

**Academic title:** Professor

**Institute:** Graduate Institute of Biomedical Engineering,  
National Chung Hsing University, Taiwan

**Contacts:**

Email: tsching@nchu.edu.tw

Handphone: +886-989572005



**Research Areas:**

- Biomedical instrumentation design
- Biosensors
- Tissue bioimpedance
- Biomedical electronics
- Assistive technology

**Position (Faculty/Department/Laboratory)**

- Graduate Institute of Biomedical Engineering
- Biomedical Instrumentation and Sensors Laboratory

### **Research Activities**

- Guest Editor of a SCI journal “Applied Science (ISSN 2076-3417)”, 2020~2022
- Committee member of Board of Education, Biomedical Engineering Society of the R.O.C., 2021
- Supervising council of the Taiwan Rehabilitation Engineering and Assistive Technology Society, since 2021
- Council member of Prosthetics and Orthotics Society of Taiwan, since 2019
- Council member of the Taiwan Rehabilitation Engineering and Assistive Technology Society, 2018~2020
- Supervising council of the Taiwan Rehabilitation Engineering and Assistive Technology Society, 2014~2017
- Conference Chair of the 4<sup>th</sup> International Symposium on Engineering and Technology (ISET 2022), 11-13 Nov 2022, Nantou County, Taiwan.
- Conference Chair of the 3rd International Symposium on Engineering and Technology (ISET 2021), 19-20 Nov 2021, Taichung, Taiwan.
- Conference Chair of the 2nd International Symposium on Engineering and Technology (ISET 2020), 14-16 Nov 2020, Nantou County, Taiwan.
- Conference Chair of the 1st International Symposium on Engineering and Technology (ISET 2020), 14-16 Nov 2020, Nantou County, Taiwan.
- Program Committee of The 18th IEEE International Conference on Bioinformatics and Bioengineering, 29-31 Oct 2018, Taichung Taiwan
- General chair of The 2nd International Conference on Biomedical and Biological Engineering (BBE2017), 26-28 May 2017, Guilin, China

### **Research Achievements and Awards:**

1. Outstanding Engineering Professor Award awarded by the Chinese Institute of Engineers (Taichung Chapter), Taiwan, 2021
2. Outstanding Service Teacher Award awarded by the College of Engineering, National Chung Hsing University, Taiwan, 2020
3. Mentor Model Award awarded by the College of Engineering, National Chung Hsing University, Taiwan, 2018
4. Outstanding Young Teacher Award awarded by the College of Engineering, National Chung Hsing University, Taiwan, 2017
5. Outstanding oral presentation award in the 2017 ISSMD & 22nd SACST, 20 May 2017, Tainan, Taiwan
6. Top prize in Biomedical Thematic Competition (Implementation group), 19 Jan 2017, Taiwan
7. The best paper award in the 2016 Symposium on Joint Research Projects Exhibition of Taichung Veterans General Hospital and Central-Region Universities, 25 Jun 2016, Taiwan
8. The best industry application award at the industry competition of the 2016 21th Symposium of Association for Chemical Sensors in Taiwan, 21 May 2016, Taiwan
9. Pride of the Nation Academic Award for Outstanding International Achievement awarded by the Taiwan International Invention Award Winners Association, Taiwan, 2015
10. University Outstanding Talent Award awarded by the Ministry of Science and Technology, Taiwan, 2015

### **ISI Selected Publications (2020-now)**

1. Yung-Kai Lin, Hsing-Ju Wu, Nguyen Van Hieu, Pei-Yi Chu, Thi Vien Thao Do, Fiona Yan-Dong Yao, Thien Luan Phan\*, Congo Tak Shing Ching\*. A New Biorecognition-Element-Free ID $\mu$ E Sensor for the Identification and Quantification of E. coli. *Biosensors* 2022, 12(8), 561; <https://doi.org/10.3390/bios12080561>
2. Congo Tak Shing Ching, Pei-Yuan Lee, Nguyen Van Hieu, Hsin-Hung Chou, Fiona Yan-Dong Yao, Sha-Yen Cheng, Yung-Kai Lin\*, Thien Luan Phan\*. Real-time, Economical Identification of Microplastics using Impedance-based Interdigital Array Microelectrodes and k-Nearest Neighbor Model. *Biotechnology and Bioprocess Engineering* 2022 (Accepted)
3. Su-Yu Liao, Kai-Hsun Tsai, Jing-Jenn Lin, Congo Tak-Shing Ching\*, You-Lin Wu\*. Characterizations of a nanocomposite biochemical-sensing membrane of  $\gamma$ -APTES incorporated with silica nanoparticles prepared by Ultrasonic Liquid Atomizer Spray. *Japanese Journal of Applied Physics* 2021; 60: 101006
4. Su-Yu Liao, Jing-Jenn Lin, Congo Tak-Shing Ching, You-Lin Wu\*. Cytotoxicity of ZnO Paper against Cancer Cells. *Sensors and Materials* 2021; 33: 3389-3397
5. Thien Luan Phan, Nguyen Van Hieu, Tzong Shiun Li, Ko-Chang Tsao, Congo Tak Shing Ching\*. Noninvasive and real-time in vivo characterization of Inflammation skin. *Skin Research and Technology* 2021; 00: 1-8
6. Yi-Tai Chen, Nguyen Van Hieu, Thien Luan Phan, Tzong Shiun Li, Siang-Ru Chen, Congo Tak Shing Ching\*. A Dynamic Joint Angle Measurement Device for an Active Hand Rehabilitation System. *Journal of Healthcare Engineering* 2021; 2021: 6688345
7. Su-Yu Liao, Jing-Jenn Lin, Congo Tak-Shing Ching, You-Lin Wu\*. Effect of Biased Neighboring Wire on Polysilicon Wire Biosensors with Sensing Membrane of  $\gamma$ -APTES Mixed with Polydimethylsiloxane-Treated Silica Nanoparticles. *ECS Journal of Solid State Science and Technology* 2021; 10(2): 027003
8. Peng-Ta Liu, Ta-Sen Wei, Congo Tak-Shing Ching\*. Quantitative Ultrasound Texture Analysis to Assess the Spastic Muscles in Stroke Patients. *Applied Sciences* 2020; 11: 11. [doi.org/10.3390/app11010011](https://doi.org/10.3390/app11010011)
9. Wen-Chi Yang, Su-Yu Liao, Thien Luan Phan, Nguyen Van Hieu, Pei-Yi Chu, Chin-Chang Yi, Hsing-Ju Wu, Kang-Ming Chang\*, Congo Tak-Shing Ching\*. An Immunosensor for the Detection of ULBP2 Biomarker. *Micromachines* 2020; 11: 568. [doi.org/10.3390/mi11060568](https://doi.org/10.3390/mi11060568)
10. Thien Luan Phan and Congo Tak-Shing Ching\*. A Reusable Mask for Coronavirus Disease 2019 (COVID-19). *Archives of Medical Research* 2020; 51: 455-457
11. Wei-Li Hsu, Carl PC Chen, Mohammad Nikkhoo, Cheng-Feng Lin, Congo Tak-Shing Ching, Chi-Chien Niu and Chih-Hsiu Cheng\*. Fatigue changes neck muscle control and deteriorates postural stability during arm movement perturbations in patients with chronic neck pain. *The Spine Journal* 2020; 20: 530-537

### Invited talks

1. Lecturer for the Central Commissioned Training Program for Prosthetist & Orthotist 2021/22 organized by the Hong Kong Hospital Authority Institute of Health Care, 13-14 Jan 2022, Hong Kong [Lecture topic: A Journey of Amputation ~ Rehabilitation and Advance; Lecture time: 11 hours]
2. Invited speaker of The 38th SENSOR SYMPOSIUM, 9-11 Nov 2021, Japan
3. Keynote speaker of The International Symposium on Applied Science 2021, 15-17 Oct 2021, Ho Chi Minh City, Vietnam
4. Keynote speaker of The Fifth International Conference on Biological Information and Biomedical Engineering (BIBE2021), 20-22 Jul 2021, Hangzhou, China
5. Keynote speaker of the 3rd International Conference on Bioscience and Medical Engineering (ICBME2021), 29-30 Jun 2021, Johor Bahru, Malaysia
6. Invited speaker of Distinguished Lecture Series, Universiti Teknologi Malaysia, 12 Nov 2020, Malaysia
7. Plenary speaker of International Convention on Rehabilitation Engineering and Technology (i-CRETE 2020), 5-7 Nov 2020, Taipei, Taiwan
8. Keynote speaker of International Conference on Biological Information and Biomedical Engineering (BIBE 2018), 6-8 Jul 2018, Shanghai, China

9. Keynote speaker of The 2nd International Conference on Biomedical and Biological Engineering (BBE2017), 26- 28 May 2017, Guilin, China
  10. Keynote speaker of The International Conference on Biological Engineering and Pharmacy (BEP2016), 9-11 Dec 2016, Shanghai, China
  11. Keynote speaker of The International Conference on Biomedical and Biological Engineering (BBE2016), 15-17 Jul 2016, Shanghai, China
- Invited speaker of The 11th Annual IEEE International Conference on Nano/Micro Engineered and Molecular Systems, 17-20 April 2016, Matsushima Bay and Sendai MEMS City, Japan

12.

The 3<sup>rd</sup> International Workshop on Engineering Physics, IC-MEMS-Sensors and  
Their Applications (3<sup>rd</sup>IWEMA2022)  
*November-25&26,2022; Ho Chi Minh City, Vietnam*

*Host by Faculty of Physics- Engineering Physic, University of Science ,  
Vietnam National University- HCMC)  
and Ono Lab, Tohoku University, Sendai, Japan*

**PLENARY SESSION (Code: PL-04)**

-----

**1.About speaker**

Title of talk: MEMS Sensors for Industry and Smart Cities

Author (s): Dzung Dao

Institution (s): Griffith University

Country: Australia

Speaker: Dzung Dao

Academic title: Professor

E-mail: d.dao@griffith.edu.au

Handphone: N/A (Overseas)

**2. Abstract**

This talk presents our research and development of MEMS (Micro-Electromechanical Systems) and its applications in industry and smart cities. Opportunities, challenges and strategies for MEMS development will also be discussed.

A Smart City uses sensor, Internet of Things (IoT), and Artificial Intelligence (AI) technologies to optimally manage energy, resources and services, and ultimately, improving the quality of life of its citizen. The technologies involve in almost all aspects of city's everyday activities, including government services, healthcare, traffic, environment, infrastructure, safety and security, to make people life more comfortable, efficient and safe. Sensors and IoT play important roles like eyes, ears and nerve system, while AI acts as brain of a Smart City. Type of sensing required in Smart City is very broad (see the Figure below), e.g. chemical, pressure, light, temperature, magnetic, sound, air/water quality, infrastructure health, etc. Sensors installed in the city infrastructures (e.g. roads, bridges, buildings, etc.), collect real-time data and send them to online Data Centres for processing

and responding using AI. For example, real-time data of traffic condition, parking spots, flooding, environment, etc. can be used to effectively control traffic, reducing local congestion and improving safety and efficiency. Real-time information of fire, structure status, water & air quality, environment, intruder, etc. in a building will enhance safety, comfort and health of residents.

MEMS sensors are promising for IoT-enabled Smart City, because they feature small size, reliable performance, low energy consumption, and low cost. Over the last two decades, MEMS have been evolving from miniaturized single-functional systems into increasingly complex integrated systems with advanced functionality, including multiple-sensing, data processing, wireless communication and sensor network.

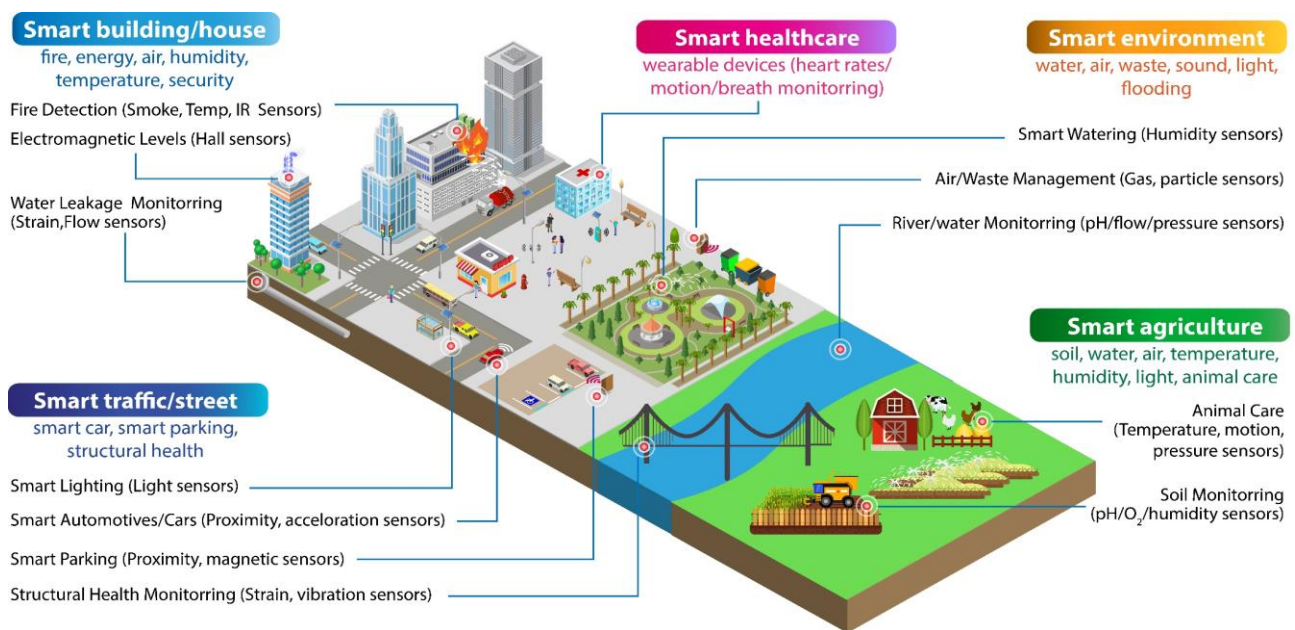

\*Keywords: MEMS, Sensors, Smart Cities,...

\*References:

### 3. Short- Biography



**Name: Professor Dzung Viet DAO**  
**Current positions and Roles**

- Professor & Head, Mechanical Engineering, Griffith University
- Director, Mechatronics Engineering Program, Griffith University

### **Education/Qualifications**

- 2003 PhD in Electro-Mechanical Systems, Ritsumeikan University, Japan
- 1997 M.Eng Mechanical Eng., Hanoi University of Science and Technology (HUST), Vietnam
- 1995 B.Eng Informatics-Mechanical Engineering, HUST, Vietnam

### **Professional History**

- 2011 to present: **Professor**, *School of Engineering & Built Environment, Griffith Uni, AUSTRALIA.*
- Apr 2007 to Dec 2011: **Chair Professor**, *MEMS, Ritsumeikan University, JAPAN.*
- Apr 2006 to Mar. 2007: **Lecturer**, *MEMS, Ritsumeikan University, JAPAN.*
- Apr 2003 to Mar 2006: **Postdoctoral fellow**, *Ritsumeikan University, JAPAN.*
- Sept 1995 to Sept 1999: **Lecturer**, *Mechanical Engineering, HUST, VIETNAM.*

### **Teaching area**

- Mechanical and Mechatronics Engineering Design, Control Systems, Electrotechnics, Advanced Manufacturing, Kinematics and Dynamics

### **Research area**

- Advanced sensing effects in nanostructured materials, semiconductors
- Micro/Nano Electromechanical Systems (MEMS), MEMS Sensors and Actuators
- Advanced Manufacturing: Micro/Nano machining technology, Additive manufacturing
- Wireless sensor network

**Publications:** 230 Journal papers, 185 Conference papers, 6 book/book-chapters

**Publication Citations:** 6000+ citations, **H-index:** 40

**Patents** (filed and granted): 17

**Research Grants:** \$10.5M (total).

**Postgraduate Supervision:** 23 PhD candidates completed.

### **Editorial Board and Conference Committees**

- Associate Editor, Sensors and Materials, Tokyo, Japan
- Editorial Board Member, J. Adv. Nat. Sci: Nanosci. Nanotechnol., IOP, UK.
- Editorial Board Member, Sensors Journal, MDPI (SCI indexed)
- Editorial Board Member, J. Sensors, Hindawi Publishing Corporation.
- Guest Editor, Sensors and Materials, Special Issue on Bio4Apps 2017, MYU KK, Japan
- General Chair of the 5th Bio4Apps, 2016, Gold Coast, Australia
- General Chair, 5th Int'l Conf. on Sustainable Design and Manufacturing, Australia, June 2018.

The 3<sup>rd</sup> International Workshop on Engineering Physics, IC-MEMS-Sensors and  
Their Applications (3<sup>rd</sup>IWEMA2022)  
November-25&26,2022; Ho Chi Minh City, Vietnam

*Host by Faculty of Physics- Engineering Physic, University of Science ,  
Vietnam National University- HCMC)  
and Ono Lab, Tohoku University, Sendai, Japan*

**PARALLEL SESSION: Invited talk**  
**(Session 1A, code: IN-01)**

-----

**1. Invited speaker**

**Title of talk:** Thermoelectric Generator with a High Integration Density for Portable and Wearable Self-Powered Electronic Devices.

**Author (s):** Nguyen Van Toan<sup>1</sup>, Truong Thi Kim Tuo<sup>2</sup>, Nguyen Van Hieu<sup>3</sup>, and Takahito Ono<sup>1,2</sup>

**Institution (s):**

<sup>1</sup>Micro System Integration Center, Tohoku University, Sendai, Japan

<sup>2</sup>Department of Mechanical Systems Engineering, Tohoku University, Sendai, Japan

<sup>3</sup>Department of Physics and Electronic Engineering, University of Science, HCMC, Vietnam

**Country:** Japan and Vietnam

**Speaker:** Nguyen Van Toan

**Academic title:** Associate Professor

**E-mail:** [nguyen.van.toan.c6@tohoku.ac.jp](mailto:nguyen.van.toan.c6@tohoku.ac.jp)

Handphone:

**2. Abstract**

**Thermoelectric Generator with a High Integration Density for Portable and Wearable Self-Powered Electronic Devices**

Nguyen Van Toan<sup>1,\*</sup>, Truong Thi Kim Tuo<sup>2</sup>, Nguyen Van Hieu<sup>3</sup> and Takahito Ono<sup>1,2,\*</sup>

<sup>1</sup>Micro System Integration Center, Tohoku University, Sendai, Japan

<sup>2</sup>Department of Mechanical Systems Engineering, Tohoku University, Sendai, Japan

<sup>3</sup>Department of Physics and Electronic Engineering, University of Science, HCMC, Vietnam

Thermoelectric generator (TEG) can convert the temperature difference  $\Delta T$  between the human body heat and its surroundings into electricity using as an electrical power source for wearable electronics. However, TEG output power is quite low due to the small harvested  $\Delta T$  between body heat and ambient environment. Typically, for wearable applications [1-2], TEG is flexible and stretchable because the human body is soft and has complex geometries. Nevertheless, if the TEG becomes small and has high performance, it can still be used for such wearable applications. To achieve high performance of TEG, besides the improving performance of thermoelectric materials, an increasing number of thermoelectric legs of the TEG can enhance the electric output power. Hundreds of n and p type thermoelectric legs could be formed on a small footprint by employing micro/nano technologies [3-5], which makes the output power of the micro-TEG higher. However, micro/nano fabrication of the micro-TEG shows some problems, including difficulty constructing the air bridge between two thermoelectric legs, complex fabrication processes, poor bonding connections (substrate and thermoelectric legs), requiring heat treatment processes (effects to performance of thermoelectric materials), limiting the height of thermoelectric legs. As a result, the output power of micro-TEG is small. Herein, micro-TEG with a high integration density using a high performance electrodeposited thermoelectric material is fabricated by an assembly technology which is simple, low cost, and green process. In addition, potential for self-powered wearable electronic devices employing the fabricated TEG is demonstrated.

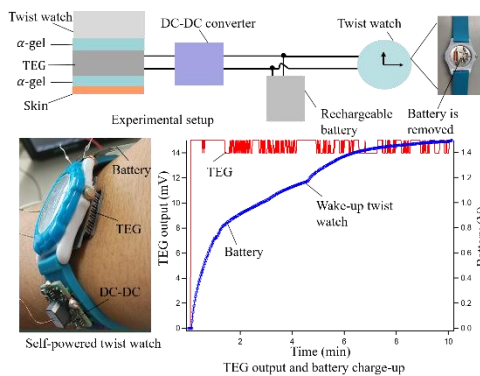

Figure 1. Self-powered wearable electronic device.

Figure 1 shows a demonstration for self-powered wearable electronic device. The human temperature is converted into usable electricity powering for a twist watch. One side of the TEG is in contact with the human skin while another side is connected to the backside of the twist watch. The arrangement of the TEG, DC-DC converter, and rechargeable battery on the twist watch is shown in Figure 1. Figure 1 also shows the recorded data of the TEG output and battery output charge. When the battery voltage level reaches approximately 1.2 V, taking approximately 5 minutes, the twist watch is powered on and runs. The current consumption of this twist watch is measured as 0.1  $\mu$ A. Once the battery is fully charged, the twist watch could normally operate for over 2000 days.

\*Keywords (5): Thermoelectric material, thermoelectric generator, portable and wearable self-powered electronic device.

\*References:

- [1] B. Lee, et al., *Nature communications*, **11**, 5948, 2020.
- [2] N.H. Trung, et al., *Applied Energy*, **210**, 467-476, 2018.
- [3] G.J. Snyder, et al., *Nature materials*, **2**, 528-531, 2003.
- [4] Y. Yu, et al., *Applied energy*, **285**, 115404, 2020.
- [5]. W. Zhang, et al., *Journal of microelectromechanical systems*, **25**, 744-749, 2016

### 3.Short- Biography

**Full name:** Nguyen Van Toan, Dr. Eng.

**Academic title:** Associate Professor

**Institute:** Micro system Integration Center, Tohoku University, Japan



**Contacts:**

Email:

nguyen.van.toan.c6@tohoku.ac.jp

Phone: +81-22-795-5806

**Biography**

**Nguyen Van Toan** received his B.S. degree in 2006 and his M.S. degree in 2009 in physics and electronics, respectively, from University of Science, Vietnam National University, Ho Chi Minh City, Viet Nam. He received his Dr. Eng. degree from Tohoku University in 2014 for research on silicon capable of integrating LSI for application to timing devices. He currently works as an Associate Professor at Micro System Integration Center, Tohoku University. He has published 67 peer-reviewed journal papers, three patents, one book, and four book chapters. His research results have been presented in over 90 conferences. He has received several awards, including Research Travel Award for IEEE-MEMS conferences (in 2017 and 2020) and for IEEE-Transducers (2017), Outstanding paper awards in IEEE-NANO and IEEE-NEMS, Best paper award in 2019 (IEEJ), and Electrical Science Promotion Award in 2022. He is pursuing an all-in-one micro/nano energy system, including energy harvesting, energy storage and sensing, and developing high-performance functional materials and devices. His current research interests include capacitive silicon resonators, optical modulator devices, thermal-to-electric power generators, gas sensing, micro-supercapacitor, Knudsen pump, ion transportation and metal-assisted chemical etching.

**Publications:** 2013-2022, around 67 International papers (ISI, SCIE, Scopus, Web)

The 3<sup>rd</sup> International Workshop on Engineering Physics, IC-MEMS-Sensors and  
Their Applications (3<sup>rd</sup>IWEMA2022)  
November-25&26,2022; Ho Chi Minh City, Vietnam

*Host by Faculty of Physics- Engineering Physic, University of Science,  
Vietnam National University- HCMC)  
and Ono Lab, Tohoku University, Sendai, Japan*

**PARALLEL SESSION: Invited talk**  
**(Session 1, code: IN-02)**

**1. Invited speaker**

Title of talk: **The review of Digital Microfluidics and Their Applications.**

Author (s): Nguyen Hoang Quan<sup>1</sup>, Nguyen Ngoc Thao Nhi<sup>1</sup>, Nguyen Hoang Long<sup>1</sup>, Nguyen Chi Nhan<sup>2</sup>, Ngo Yen Khanh<sup>3</sup>, Ho Thanh Huy<sup>1</sup>, Huynh Chan Khon<sup>3</sup>, and Nguyen Van Hieu<sup>1</sup>.

Institution (s): <sup>1</sup>MBiEE Lab and <sup>2</sup>IoRE Lab, Department of Physics and Electronic Engineering, Faculty of Physics- Engineering Physics, VNUHCM- University of Science, VNUHCM, Vietnam; <sup>3</sup>Lab on a chip and biosensors, School of Biomedical Engineering, International University, VNUHCM Vietnam.

Country: Viet Nam

Speaker: Nguyen Van Hieu

Academic title: Associate Professor, Ph.D,

E-mail: nvhieu@hcmus.edu.vn

Handphone: +84.90.629.704

**2. Abstract**

Digital Microfluidics (DMF) offers several advantages over continuous domain microfluidics. Due to experimental purpose, the individual droplets in sample volume is further reduced to microliter, nanoliter or down to picoliter. As demonstrated by microfluidics, lower the reagent volume the faster are the results. Hence individual droplets give even faster results than continuous flows. Also the amount of reagent required in chemical and biological assays which can be difficult to obtain and also economically infeasible can be used in very small amounts thus reducing wastage and economizing the

problem. How to scale their volumes in experimental works will be a importance step to get the exact measuring results. There are several difficulties involved in handling of microdroplets that has to be taken in reduction of heat transfer. We must take in the choice of material for every function it has to perform as regards with the these liquid.

Nowaday, the applications of DMF are various disciplines as Biology, Chemistry, Chemical Engineering,...etc and are still expanding. The most notable of them include portable assays that we can mentionas DNA, PCR and Proteomics. With DMF, the samples can be created and analyzed in parallel on the same chip thus effectively saving time and improving efficiency.

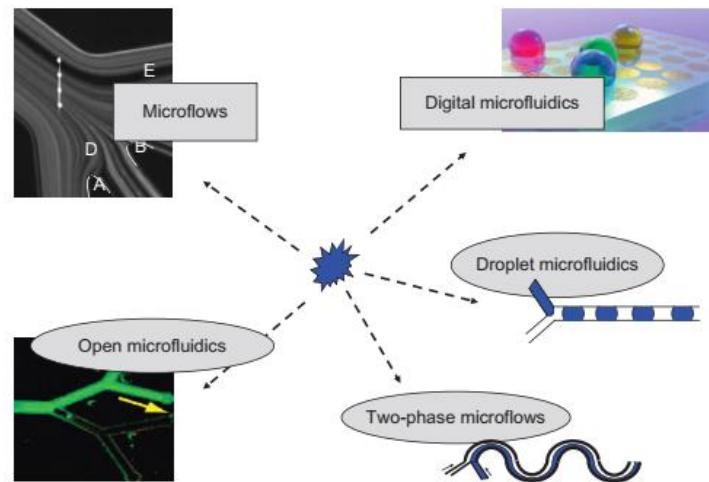

Fig.1. The different domains (toolbox) of microfluidics; the arrows between the different toolboxes symbolize the connections; continuous arrows correspond to established links; dotted arrows to not yet established links [1].

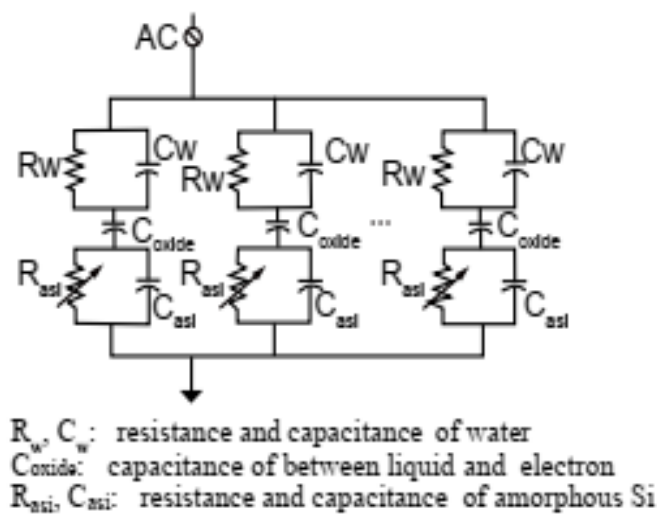

Fig.2. The equivalent circuit for Opto-electrowetting device (as well as example [2])

With the desire to review research and application cooperation in the field of MEMS and biomedical engineering [3-6], in this report, some techniques for designing and

manufacturing for DMF are synthesized, analyzed and their proposed applications via DMF technique. We would like to thank the authors for sharing and for permission to use their publications in this report.

\*Keywords: Digital Microfluidics (DMF), droplets, Opto-electrowetting device, DNA, PCR, proteomics.

\*References:

- [1]. W. Satoh, H. Hosono, H. Suzuki, On-chip microfluidic transport and mixing using electrowetting and incorporation of sensing functions, *Anal. Chem.* 77 (2005) 6857-6863.
- [2]. Sukhatme S, Agarwal A (2012) Digital Microfluidics: Techniques, Their Applications and Advantages. *J Bioengineer & Biomedical Sci* S8:001. doi:10.4172/2155-9538.S8-001.
- [3]. Hwang H, Park JK (2011) Optoelectrofluidic platforms for chemistry and biology. *Lab Chip* 11: 33-47.
- [4]. Chuang HS, Kumar A, Steven TW (2008) Open opto-electro-wetting droplet actuation. *Appl. Phys. Lett.* 93 064104: 1-4.
- [5]. Chiou PY, Chang Z, Ming CW (2008) Droplet Manipulation With Light on optoelectrowetting Device. *Journal of Microelectromechanical Systems* 17:133-138.
- [6]. Le, H., Mai-Thi, H.-N., Le, X., Tran, N. Q., Tu Tran, C., & Huynh, K. (2022). The concentration-independence cellular effects of fibronectin adsorbed on material surfaces with different hydrophobicities. *Vietnam Journal of Biotechnology*, 20(3), 435–444. <https://doi.org/10.15625/1811-4989/16585>.

### 3.Short- Biography

**Full name:** Nguyen Van Hieu

**Academic position:** Associate Professor, Ph.D

**Position:**

- Deputy Director, Department of Science and Technology, Vietnam National University HoChiMinh city (VNUHCM), Vietnam.

- Inviting Senior lecturer, MBiEE lab, Department of Physics and Electronic Engineering, Faculty of Physics- Engineering Physics, University of Science, VNUHCM, Vietnam.

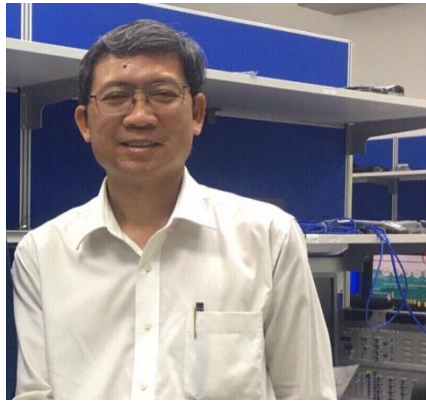
**Contacts:**

Email: [nvhieu@hcmus.edu.vn](mailto:nvhieu@hcmus.edu.vn).

Handphone: (+84) 903.629704

Website:

<https://en.hcmus.edu.vn/>

**Research Areas:**

- MEMS, Biosensors and UVLEDs
- Digital MicroFluidics for Biomedical Applications
- Electronic Engineering Circuits (Equipments, IoT,...)

**Academic Unit:**

- Current: Lab of Biosensors and Electronic Engineering (BiEE Lab);
- 2007- Oct. 2022:  
Dept. of Physics and Electronic Engineering  
Faculty of Physics and Engineering Physics  
University of Science, VNUHCM.

**Academic Activities**

- Visiting senior lecturer
- Member: the Physics Society of Vietnam, the editorial board of the Journal of the Korean Institution of Electrical and Electronic Engineers (IKEEE), Institute of Electrical Engineers of Japan (IEEJ).
- International research works: Inviting researcher (Ritsumeikan Univ, Jp), research professor (Sophia Univ, Jp), co-Principal investigator (2021-2023, NCHU-Taiwan).
- Invited talks: ASPA2013 (in SHTP), 4S international Conference 2010, 2012, SHTP Annual Conference 2014, STT41 (Thailand), SHTP Annual Conference 2016, MRS (Thailand 2017), IKEEE conference (2017, 2018), 7th&8th Benjamitra Conference (2016, 2018, Thailand), ODF20, ISET2021, OPTIC2022 (Taiwan),...
- Publications: over 40 international, domestic papers and 30 proceeding in workshop, conferences;
- Educations: lecturer for 3 subjects, scientific supervisors more than 50 bachelors, master and PhD students.

**Research Achievements and Awards:**

*Research projects (2005-2018): Chief of Project*

- [1]. The crystalline electric field of  $RRhIn_5$  Code of Project: B2008-18-12, Support by Vietnam National University – HCM City, 2008-2009.
- [2]. The electrical resistivity properties of  $RRhIn_5$ . Code project: 49/2008/HĐ-ĐT, Asia Research Center (Vietnam National University, Hanoi) and the Korea for Advanced Studies, 2008-2009.
- [3]. The fabrication and application of UVLED, Code of project: 86/HĐ-SKH-CN-2010. Research project 2010-2013, support by the Government of Hochiminh City, Vietnam (co-operation with Ritsumekan University, Japan)
- [4]. The UVLEDs for water disinfection, Code of Project: B2011-18-33, Support by Vietnam National University-HCM City, 2011-2012.
- [5]. The UVLEDs for water disinfection and ozone concentration measurement, Code of Research: CNC.06/DAPT14, National project, Support by the Ministry of Science and Technology, Vietnam, 2014-2017.

*Intellectual Property*

[1]. Nguyen Van Hieu, Ngo Vo Ke Thanh and Nguyen Ngoc Dao: IP certificate: *Cấu trúc “kép” đa giềng lượng tử MQW cho phát xạ cực tím*. No. 81529/QĐ-SHTT (MOST, Vietnam, 2016).

#### Books

- [1]. Nguyen Van Hieu, book for study, MicroElectroMechanicalSystem: Design and Simulation (in Vietnamese), VNUHCM Publisher House (320 pages, Apr., 2011).
- [2]. Nguyen Van Hieu and Nguyen Dac Hien, book for study, Electrical Safety Engineering in Industrial (in Vietnamese), VNUHCM Publisher House (290 pages, June, 2011) (ISBN: 978-604-73-0607-7).
- [3]. Nguyen Van Hieu, Book for study: Electronic Circuits and Their Applications VNUHCM Publisher House (250 pages, Dec, 2015) (ISBN: 978-604-73-3739-2).

#### Research Awards

- [1]. Third prize of the Scientific and Technological Invention Awards, Government of Hochiminh City, Vietnam (May 2004) for Scientific project.
- [2]. Outstanding Poster Price, in Osaka University – Asian Pacific – Vietnam National University- Hanoi Forum 2005: On Frontiers of Basic Science – Mathematics (Sep. 27th-29th , 2005).
- [3]. Third prize of VIFOTEC, National Awards, Hanoi, Vietnam 2011 (May 2012) for Scientific project.
- [4]. Third prize of the Scientific and Technological Invention Awards, Government of Hochiminh City, Vietnam (June 2011) for Scientific project.
- [5]. Fourth prize of the 4th Scientific and Technological Invention Awards, Government of Binh Duong Province, Vietnam (May 2012) for Scientific project.
- [6]. Honor Medal for the Young Scientist and Inventor, by Vietnam Labor Union, (May, 2012)
- [7]. Fourth prize of the 6th Scientific and Technological Invention Awards, Government of Binh Duong Province, Vietnam (April, 2015) for Scientific project.

#### ISI Selected Publications (2014-now)

- [1]. Ho Thanh Huy,...Nguyen Van Hieu and T.Ishida: *Vortex Doping Into Superconducting Mo80Ge20 Square Network*, **IEEE Transactions on Magnetics** Vol. 50 (2014);
- [2]. Le Van Men, Vu The Dang, Nguyen Huu Trung and Nguyen Van Hieu: *Measurement technique of ozone desity by using UV sensor system*, Journal of **IKEEE**.Vol.19,No.1,1080-1086 (ISSN: 1226-7244 ,Print) (2015);
- [3]. Yo Sheng Lin, Guo Hao Li and Nguyen Van Hieu: *A 75–85GHZ Down-conversion mixer with intergrated marchand baluns in 90 nm CMOS with excellent matching and port-to-port isolation for automotive radars*, **Microwave and Optical Technology Letters**, Vol. 57, No. 1,73-80 (SCI);
- [4]. Congo Tak-Shing Ching, Teng-Yun Cheng, Nguyen Van Hieu and Lin-Shien Fu: *Liver Cancer Detection by a Simple, Inexpensive and Effective Immunosensor with Zinc Oxide Nanoparticles*, **Sensors 2015**; 15: 29408–29418 (SCI)(2015) (Q2-SCImago/Scopus);

- [5].Wen-Chi Yang, Su-Yu Liao, Thien Luan Phan, Nguyen Van Hieu, Pei-Yi Chu, Chin-Chang Yi, Hsing-Ju Wu, Kang-Ming Chang, Congo Tak-Shing Ching: *An Immunosensor for the Detection of ULBP2 Biomarker*. **Micromachines** **2020**; 11: 568 (Q2-SCImago/Scopus);
- [6]. Thien Luan Phan, Nguyen Van Hieu, Tzong Shiun Li, Ko-Chang Tsao, Congo Tak Shing Ching: *Noninvasive and real-time in vivo characterization of Inflammation skin*. **Skin Research and Technology** **2021**; 00: 1-8 (Q2-SCImago/Scopus);
- [7]. Yi-Tai Chen, Nguyen Van Hieu, Thien Luan Phan, Tzong Shiun Li, Siang-Ru Chen, Congo Tak Shing Ching: *A Dynamic Joint Angle Measurement Device for an Active Hand Rehabilitation System*. **Journal of Healthcare Engineering** **2021**; 2021: 6688345 (Q3-SCImago/Scopus);
- [8]. Nguyen Van Toan, Truong Thi Kim Tuoi, Nguyen Van Hieu and Takahito Ono: *ThermoElectroc Generator with a high integration density for portable and wearable self-powered electronic devices*, **Energy Conversion and Management** 245 (2021) 114575 (Q1-SCImago/Scopus).

The 3<sup>rd</sup> International Workshop on Engineering Physics, IC-MEMS-Sensors and  
Their Applications (3<sup>rd</sup>IWEMA2022)  
November-25&26,2022; Ho Chi Minh City, Vietnam

*Host by Faculty of Physics- Engineering Physic, University of Science,  
Vietnam National University- HCMC)  
and Ono Lab, Tohoku University, Sendai, Japan*

**PARALLEL SESSION: Invited talk**  
**(Session 1, code: IN-03)**

**1. Invited speaker**

Title of talk: Experimental Studies on Spatial Resolution of a Delay-Line Current-Biased Kinetic-Inductance Detector

Author (s): The Dang Vu<sup>1,2</sup>, Hiroaki Shishido<sup>3</sup>, Kazuya Aizawa<sup>2</sup>, Takayuki Oku<sup>2</sup>, Kenichi Oikawa<sup>2</sup>, Masahide Harada<sup>2</sup>, Kenji M. Kojima<sup>4</sup>, Shigeyuki Miyajima<sup>5</sup>, Kazuhiko Soyama<sup>2</sup>, Tomio Koyama<sup>1</sup>, Mutsuo Hidaka<sup>6</sup>, Soh Y. Suzuki<sup>7</sup>, Manobu M. Tanaka<sup>8</sup>, Masahiko Machida<sup>9</sup>, Shuichi Kawamata<sup>1</sup> and Takekazu Ishida<sup>1</sup>

Institution (s):

<sup>1</sup>Division of Quantum and Radiation Engineering, Osaka Metropolitan University, Sakai, Osaka 599-8570, Japan

<sup>2</sup>Materials and Life Science Division, J-PARC Center, Japan Atomic Energy Agency, Tokai, Ibaraki 319-1195, Japan

<sup>3</sup>Department of Physics and Electronics, Osaka Metropolitan University, Sakai, Osaka 599-8531, Japan

<sup>4</sup>Centre for Molecular and Materials Science, TRIUMF, 4004 Wesbrook Mall, Vancouver, BC V6T 2A3, Canada

<sup>5</sup>Advanced ICT Research Institute, National Institute of Information and Communications Technology, 588-2 Iwaoka, Nishi-ku, Kobe, Hyogo 651-2492, Japan

<sup>6</sup>Advanced Industrial Science and Technology, Tsukuba, Ibaraki 305-8568, Japan

<sup>7</sup>Computing Research Center, Applied Research Laboratory, High Energy Accelerator Research Organization (KEK), Tsukuba, Ibaraki 305-0801, Japan

<sup>8</sup>Institute of Particle and Nuclear Studies, High Energy Accelerator Research Organization (KEK), Tsukuba, Ibaraki 305-0801, Japan

<sup>9</sup>Center for Computational Science & e-Systems, Japan Atomic Energy Agency, 178-4-4 Wakashiba, Kashiwa, Chiba 277-0871, Japan.

Speaker: Vu The Dang

Academic title: Ph.D

E-mail: vuthedang@omu.ac.jp

Handphone:(081)090-8163-7979

## 2. Abstract

Neutron imaging has been recognized as one of the most powerful tools for conducting nondestructive inspection of a wide range of materials. We first proposed the idea of a superconducting neutron detector called a current-biased kinetic inductance detector (CB-KID) with a neutron conversion layer of  $^{10}\text{B}$  [1]. The practical usefulness was tested with various samples in view of good spatial linearity between the Gd-islands' sizes evaluated not only by neutron transmission images but also by SEM images for various different-sized samples [2], the Bragg-edge detection in neutron transmission spectra by sampling very narrow areas [3], the Bragg-dip imaging of SmSn mosaic structure [4]. The CB-KID has been systematically investigated to understand its characteristics and to optimize the operating conditions for improving the spatial resolution, the temporal resolution, and the detection efficiency [5,6]. In this paper, we explored the spatial resolution of the CB-KID from the viewpoint of structure of neutron detector, thickness of  $^{10}\text{B}$  layer, and the operating condition of the CB-KID. By using Gd Siemens patterns and  $^{10}\text{B}$ -dot arrays, a spatial resolution of 12-15  $\mu\text{m}$  was achieved so far. The Gd Siemens pattern provided a simple way to estimate the spatial resolution while the  $^{10}\text{B}$ -dot array sample revealed more details about spatial resolutions of vertical and horizontal directions of the CB-KID detector. We consider that CB-KID could be useful for various purposes.

This work is partially supported by Grant-in-Aid for Scientific Research (A) (No. JP21H04666) and Grant-in-Aid for Early-Career Scientists (No. JP21K14566) from JSPS. The experiments at the Materials and Life Science Experimental Facility (MLF) of the J-PARC were supported by the MLF project program (No. 2021P0501).

\*Keywords (5): Neutron detector, CB-KID, Siemens, Born Dots, Spatial resolution

\*References:

- [1] Ishida T, Yoshioka N, Narukami Y, Shishido H, Miyajima S, Fujimaki A, Miki S, Wang Z, Hidaka M 2014 Toward Mega-pixel Neutron Imager Using Current-Biased Kinetic Inductance Detectors of Nb Nanowires with  $^{10}\text{B}$  Converter, *J Low Temp Phys* **176** 216
- [2] Vu T D, *et al.* 2021 Practical tests of neutron transmission imaging with a superconducting kinetic-inductance sensor *Nucl. Instrum. Meth. Phys. Res. A* **1006** 165411
- [3] Vu T D, *et al.* 2022 Narrow-area Bragg-edge transmission of iron samples using superconducting neutron sensor *J. Phys.: Conf. Ser.* **2323** 012028
- [4] Shishido H, *et al.* 2022 Neutron Imaging toward Epithermal Regime using a Delay Line Current-Biased Kinetic-Inductance Detector *J. Phys.: Conf. Ser.* **2323** 012029
- [5] Vu T D, *et al.* 2019 Temperature dependent characteristics of neutron signals from a current-biased Nb nanowire detector with  $^{10}\text{B}$  converter *J. Phys.: Conf. Ser.* **1293** 012051
- [6] Vu T D, *et al.* 2020 Kinetic inductance neutron detector operated at near critical temperature *J. Phys.: Conf. Ser.* **1590** 012036

## 3. Short- Biography

**Full name:** Vu The Dang, Ph.D.

**Academic title:** Assistant Professor

**Institute:** Osaka Metropolitan University, Japan

**Contacts:**

Email:

vuthedang@omu.ac.jp

Handphone:

(+81)-90-8163-7979



Research gate



ORCID

**1. Research Areas:**

- Superconducting Devices.
- Neutron transmission imaging.
- Magnetic field imaging.

**2. Faculty/Department/Laboratory**

- Division of Quantum and Radiation Engineering, Kawamata Lab.

**3. Research Activities**

1. Developing a superconducting neutron imaging system toward a sub-micrometer neutron transmission image.
2. Construct a vector scanning SQUID microscope system to investigate the vector magnetic field images.
3. Studying vortex distribution in specific samples such as star-shaped pattern without pinning and pinning, circular disk with sector defect and different opening angles of deficit.

**4. Research Achievements and Awards:**

1. JSPS Wakate project (JP21K14566) for studying “Operating principle of the superconducting neutron detector” in two year 2021-2022.
2. IEEE-CSC Financial Support Award for attending EUCAS 2017 Conference (17<sup>th</sup> September – 21<sup>st</sup> September 2017) held at in the International Conference Centre of Geneva (CICG), Geneva, Switzerland (~1,100 USD)

**5. ISI Selected Publications**

- [1]. The Dang Vu, *et al.*, “Practical tests of neutron transmission imaging with a superconducting kinetic-inductance sensor” *Nuclear Inst. and Methods in Physics Research, A* **1006** (2021) 165411
- [2]. The Dang Vu, *et al.*, “Homogeneity of neutron transmission imaging over a large sensitive area with a four-channel superconducting detector” *Supercond. Sci. Technol.* **34** (2021) 015010.
- [3]. The Dang Vu, *et al.*, “SQUID microscopy for mapping vector magnetic fields” *Supercond. Sci. Technol.* **32** (2019) 115006 (11pp)
- [4]. The Dang Vu, *et al.*, “Confined vortices in de facto mesoscopic Mo<sub>80</sub>Ge<sub>20</sub> disks with sector defects” *Supercond. Sci. Technol.* **31** (2018) 125009 (12pp)
- [5]. The Dang Vu, *et al.*, “Scanning SQUID Microscopy for Sensing Vector Magnetic Field” *IEEE transactions on applied superconductivity* **28** (2018) 1601105.
- [6]. Vu The Dang, *et al.*, “Vortex Distribution in Small Star-Shaped Mo<sub>80</sub>Ge<sub>20</sub> Plate”, *Physica C* **533**(2017), Pages 44–48

The 3<sup>rd</sup> International Workshop on Engineering Physics, IC-MEMS-Sensors and  
Their Applications (3<sup>rd</sup>IWEMA2022)  
November-25&26,2022; Ho Chi Minh City, Vietnam

*Host by Faculty of Physics- Engineering Physic, University of Science ,  
Vietnam National University- HCMC)  
and Ono Lab, Tohoku University, Sendai, Japan*

**PARALLEL SESSION: Invited talk**

**(Session 1, code: IN-04)**

**1. Invited speaker**

Title of talk: Entangling heat and charge in quantum material for thermoelectric application

Author (s): Nguyen Tuan Hung

Institution (s): Frontier Research Institute for Interdisciplinary Sciences, Tohoku University,  
Sendai, Japan

Country: Japan

Speaker: Nguyen Tuan Hung

Academic title: Assistant Professor

E-mail: halubai.sekhar@nitech.ac.jp

Handphone: +81-9068714685

**2. Abstract**

**Entangling heat and charge in quantum material for thermoelectric  
application**

Nguyen Tuan Hung<sup>1,2</sup>

<sup>1</sup>Frontier Research Institute for Interdisciplinary Sciences, Tohoku University, Sendai,  
Japan

<sup>2</sup>Department of Physics, Tohoku University, Sendai, Japan

Email: [nguyen@tohoku.ac.jp](mailto:nguyen@tohoku.ac.jp); Homepage: <https://nguyen-group.github.io/>

Entangling heat and charge in the material can help to convert waste heat to electricity, so-called thermoelectricity that provides an ideal supply for the Internet of things (IoT) sensors. Finding the thermoelectric (TE) material with high-performance energy conversion is the most important goal in this field. However, it is not easy because of the interdependence of the TE transport parameters (i.e. Seebeck coefficient, electrical

conductivity, and thermal conductivity). In order to solve this fundamental problem, attempts started for the thermoelectricity of low-dimensional materials in 1993 when Hicks and Dresselhaus presented the quantum confinement effect [1]. This effect is based on the fact that the density of states has sharp peaks (or so-called van Hove singularity) at the energy edges of the dimensional materials [1, 2]. The van Hove singularity also can occur in other quantum materials such as the atomic layers and topological materials due to their unique energy band structure. On the other hand, the emergent 3D quantum semimetals show many features (high carrier mobility, low thermal conductivity, etc.) that could be beneficial to improve TE properties [3]. In this talk, first, we show how low-dimensional materials improve TE performance. In particular, we will discuss the high TE performance of the monolayer InSe [4] and tetradymites [5]. Second, we will discuss the TE properties of the 3D Dirac/Weyl/Nodal-line semimetals with non-trivial band topology by the semi-analytical calculation with the two-band model and the first-principles calculations [6, 7].

### References

- [1] L. D. Hicks, M. S. Dresselhaus, *Phys. Rev. B* 47, 12727 (1993); *Phys. Rev. B* 47, 16631 (1993).
- [2] N. T. Hung, R. Saito, *Adv. Quantum Technol.* 4, 2000115 (2021).
- [3] B. Skinner and L. Fu, *Sci. Adv.* 4, eaat2621 (2018).
- [4] N. T. Hung, A. R. T. Nugraha and R. Saito, *Appl. Phys. Lett.* 111, 092107 (2017).
- [5] N. T. Hung, A. R. T. Nugraha, R. Saito, *Nano Energy* 58, 743 (2019).
- [6] N. T. Hung, A. R. T. Nugraha, J. M. Adhidewata, and R. Saito, *Phys. Rev. B* 105, 115142-1-5 (2022).
- [7] P. R. Pratama, R. Saito, and N. T. Hung, *Phys. Rev. B (Letter)* 106, L081304 (2022).

### 3. Short- Biography

Full name: Nguyen Tuan Hung, Dr.

Academic title: Assistant Professor

Institute: Frontier Research Institute for Interdisciplinary Sciences, Tohoku University, Japan



#### Biography

**Nguyen Tuan Hung** is an assistant professor at the Frontier Research Institute for Interdisciplinary Sciences, Tohoku University, Japan. He received a Ph.D. with a Joint Program for Leading Graduate Schools from Tohoku University in March 2019 with a shortened period. He was awarded the Aoba Society Prize for the Promotion of Science from Tohoku University in 2017, Research Fellowships for Young Scientists from Japan Society for the Promotion of Science (JSPS) in 2018, and Tohoku University Prominent Research Fellow in 2021. His research interests are in the theory and simulation of energy materials with applications to thermoelectricity, all-solid-state batteries, photovoltaics, and artificial muscles. He also was the author of the textbook “Quantum

#### Contacts:

Email: [nguyen@tohoku.ac.jp](mailto:nguyen@tohoku.ac.jp)

**Selected Journal Papers**

1. **N. T. Hung**, E. H. Hasdeo, A. R. T. Nugraha, M. S. Dresselhaus and R. Saito, Quantum effects in the thermoelectric power factor of low-dimensional semiconductors, *Phys. Rev. Lett.* 117, 036602 (2016).
2. **N. T. Hung**, A. R. T. Nugraha and R. Saito, High-performance three-dimensional carbon Archimedean lattices electromechanical actuators, *Carbon* 125, 472-479 (2017).
3. **N. T. Hung**, A. R. T. Nugraha and R. Saito, Universal curve of optimum thermoelectric figure of merit for bulk and low-dimensional semiconductors, *Phys. Rev. Appl.* 9, 024019 (2018).
4. **N. T. Hung**, A. R. T. Nugraha and R. Saito, Designing high-performance thermoelectrics in two-dimensional tetradymites, *Nano Energy* 58, 743-749 (2019).
5. **N. T. Hung**, L. C. Yin, P. D. Tran and R. Saito, Simultaneous anionic and cationic redox in Mo<sub>3</sub>S<sub>11</sub> polymer electrode of sodium-ion battery, *J. Phys. Chem. C* 123, 30856–30862 (2019).
6. **N. T. Hung** and R. Saito, The origin of quantum effects in low-dimensional thermoelectric materials, *Adv. Quantum Technol.* 4, 2000115 (2021)
7. **N. T. Hung**, A. R. T. Nugraha, J. M. Adhidewata and R. Saito, Enhanced thermoelectric performance by van Hove singularities in the density of states of type-II nodal-line semimetals, *Phys. Rev. B* 105, 115142-1-5 (2022).
8. F. R. Pratama, R. Saito and **N. T. Hung**, Magneto-Seebeck coefficient of the Fermi liquid in three-dimensional Dirac and Weyl semimetals, *Phys. Rev. B: Lett.* 106, L081304 (2022).

The 3<sup>rd</sup> International Workshop on Engineering Physics, IC-MEMS-Sensors and  
Their Applications (3<sup>rd</sup>IWEMA2022)  
*November-25&26,2022; Ho Chi Minh City, Vietnam*

*Host by Faculty of Physics- Engineering Physic, University of Science,  
Vietnam National University- HCMC)  
and Ono Lab, Tohoku University, Sendai, Japan*

**PARALLEL SESSION: Invited talk**  
**(Session 1, code: IN-05)**

**1. Invited speaker**

Title of talk: Electrohydrodynamic atomization (EHDA)

Author (s): Van Dau

Institution (s): Griffith University

Country: Australia

Speaker: Van Dau

Academic title: Senior Lecturer

E-mail: v.dau@griffith.edu.au

Handphone: N/A (Overseas)

**2. Abstract**

Electrohydrodynamic atomization (EHDA), often referred to electrospinning, electrospraying and electrohydrodynamics, is a promising and powerful technique to generate polymeric particles or fibres. In mechatronic and chemical engineering, they are used to generate nanofiber, printing electronics, material synthesis and material analysis. In biochemical engineering, they are used to create nanofiber for controlled release of active ingredient, nanomedicine, microdroplet for lab-on-chip. They also serve as a platform for tissue engineering, restoration and treatments. In this paper, we presents our recent work in EHDA and some achievement toward an EHDA system that generates highly uniform nanofibers. One of the approaches is to yield a concentrated electric field at a unique point on the nozzle cross-section to facilitate liquid protrusion, which is then developed into a cone jet and then stably disintegrated into nanofibre with good uniformity by not too high applied voltage. The generated products by the present method possesses high sensitivity and good stability, which have been investigated and evaluated by experimental results.

\*Keywords: Micro/nano particles, fiber, drug delivery, electrohydrodynamics, electrospray/electrospinning

\*References:

### 3.Short- Biography

#### Current positions & Roles

- Senior Lecturer, Mechanical Engineering, Griffith University

#### Education/Qualifications

- 2007 PhD in Micro/Nano Electro-Mechanical Systems, Ritsumeikan University, Japan



#### Professional History

- 2021 to present: *School of Engineering and Built Environment, Griffith University, AUSTRALIA.*
- 2018 to 2021: **Lecturer**, *School of Engineering and Built Environment, Griffith University, AUSTRALIA.*
- Apr 2011 to Sep 2018: **Research Scientist**, *Environmental Health, Sumitomo Chemical, JAPAN.*
- Apr 2010 to Mar 2011: **Research Scientist**, *Sumitomo Chemical UK, UNITED KINGDOM.*
- Sep 2007 to Mar 2010: **JSPS Postdoctoral fellow** (Japan Society for the Promotion of Science), *Ritsumeikan University, JAPAN.*

#### Teaching area

- Computational Fluid Dynamics, Finite Element Analysis, Advanced Manufacturing

#### Research areas

- Advanced Manufacturing: Micro/Nano machining technology, MEMS/NEMS, Additive manufacturing
- Electrohydrodynamics, Nanofibers and Nanoparticles
- Sensors for harsh environments

**Publications:** 90+ Journal papers, 70+ Conference papers

**Patents** (filed and granted): 22 (with 9 US patents granted; latest patent

“Electrohydrodynamic Atomization” with

Griffith Enterprise, 2019, application No. LU101432)

**Research Grants:** >**\$2.5M total**. (some grants received since joining Griffith University (10/2018) listed below)

1. 2021-2022, Innovative Manufacturing Cooperative Research Centre grant (IMCRC) (CI), Development of

smart sensor system for soft soil engineering and construction safety, **A\$100,000**

2. 2021-2022, Innovative Manufacturing Cooperative Research Centre grant (IMCRC) (**2nd CI**), Development

of a miniaturised robotic laser device for ultra-precise and pain-free dentistry, **A\$200,000**

3. 2021-2022, Griffith University Internal Grants (**2nd CI**), HF Vapor Etcher for MEMS sensors and actuators

fabrication, **A\$217,000**

4. 2021, Griffith Science Internal Grants (**Lead CI**), Airborne Nanoparticle Size and Charge Measurement

Suite, **A\$69,000** (incl. A\$8k from school/centres)

5. Department of Foreign Affairs and Trade grant, 2nd CI, 2020-2021, “Low-power and Robust Sensor

Network for Flood Monitoring and Management”, **\$400,000**

6. Foundation for Australia-Japan Studies (FAJS) grant, CI, 2019-2020, “*Superior Sensor Network (SSN) for*

*Harsh Environments*”, **\$145,000**

7. Consultancy & Commercial Research grant, CI, 2019-2021, Investigation of SiC/Si on Ceramic based

Micromachined Sensors, **\$60,000**

8. Griffith University Internal grant, Lead CI, 2019, Bipolar electrostatic atomising system, **\$15,000**

#### **Awards**

Best Paper Award, AP SDEWES Conference, Gold Coast, Australia, 4/2020.

Best Paper Award – Runner up, IEEE MEMS2021, 1/2021.

#### **Editorship:**

Associate editor, Australian Journal of Mechanical Engineering, Engineers Australia

Associate editor, Journal, MDPI

Guest Editor, Sensors and Materials, Special Issue on Magnetic Nanostructures for Life, Energy and

Environment, 2021, MYU K.K., Tokyo, Japan

The 3<sup>rd</sup> International Workshop on Engineering Physics, IC-MEMS-Sensors and  
Their Applications (3<sup>rd</sup>IWEMA2022)  
November-25&26,2022; Ho Chi Minh City, Vietnam

*Host by Faculty of Physics- Engineering Physic, University of Science ,  
Vietnam National University- HCMC)  
and Ono Lab, Tohoku University, Sendai, Japan*

**PARALLEL SESSION**

**(Session 1, code: IN-06)**

-----

**1. Invited speaker**

Title of talk: Deposition of high porous layer on TiO<sub>2</sub> rutile nanorod-flower surface using titanium RF post deposition and anodization process towards Dye-sensitize solar cell efficiency enhancement

Author (s): Megat Muhammad Ikhsan Megat Hasnan<sup>1</sup>, Nafarizal Nayan<sup>2</sup>, Mohd Khairul Ahmad<sup>2</sup>, Zulkifli Azman<sup>2</sup> and I.M. Noor<sup>3</sup>

Institution (s):

<sup>1</sup>Faculty of Engineering, Universiti Malaysia Sabah, Jalan UMS, 88400, Kota Kinabalu, Sabah, Malaysia.

<sup>2</sup>Microelectronic and Nanotechnology-Shamsuddin, Research Center (MiNT-SRC), Universiti Tun Hussein Onn Malaysia (UTHM), 86400 Parit Raja Johor, Malaysia.

<sup>3</sup>Physics Division, Centre of Foundation Studies for Agricultural Science, Universiti Putra Malaysia, 43400 UPM Serdang, Selangor, Malaysia

Country: Malaysia

Speaker: Megat Muhammad Ikhsan Megat Hasnan

Academic title: PhD, Senior Lecturer

E-mail: megatikhsan@ums.edu.my Handphone: +601110944376

**2. Abstract**

**Deposition of high porous layer on TiO<sub>2</sub> rutile nanorod-flower surface  
using titanium RF post deposition and anodization process towards Dye-  
sensitize solar cell efficiency enhancement**

<sup>1</sup>Faculty of Engineering, Universiti Malaysia Sabah, Jalan UMS, 88400, Kota Kinabalu, Sabah, Malaysia.

<sup>2</sup>Microelectronic and Nanotechnology-Shamsuddin, Research Center (MiNT-SRC), Universiti Tun Hussein Onn Malaysia (UTHM), 86400 Parit Raja Johor, Malaysia.

<sup>3</sup>Physics Division, Centre of Foundation Studies for Agricultural Science, Universiti Putra Malaysia, 43400 UPM Serdang, Selangor, Malaysia

Titanium dioxide ( $\text{TiO}_2$ ) is one of the most popular materials used electrode for energy and sensor application such photovoltaic, photodetector, thermoelectric (TE), dye-sensitized solar cells (DSSCs), gas sensors and bio-sensors. Nanostructures of  $\text{TiO}_2$  such as nanorods, nanowires, nanocorals, hierarchical microspheres, nanotubes and nanoflower reportedly can improve the performance of through optimisation of the  $\text{TiO}_2$  active surface area, bandgap, redox reaction, thermal conductivity and electrical conductivity. Concurrent enhancement in both light-harvesting and electron transportation at the electrode surface can be achieved by having a combination of 0D, 1D, 2D and 3D nanostructure  $\text{TiO}_2$ .  $\text{TiO}_2$  rutile nanorod/nanoflower (T-NRF) that synthesized using a simple one-step hydrothermal method has shown promising fabrication method of tailoring crystal nanostructure for optimising DSSC performance. In case of DSSC, unfortunately, this method still faces limitation due to the low dye absorption and fast recombination of the rutile phase. In this work, we use additional post deposition technique after hydrothermal which are Radio Frequency (RF) sputtering of Titanium layer on T-NRF and followed by anodization process in ammonium fluoride in order to enhance surface area by forming high porous  $\text{TiO}_2$  nanoflower surface. In this work, the surface modification has able to enhance solar and quantum efficiency of the conventional T-NRF.

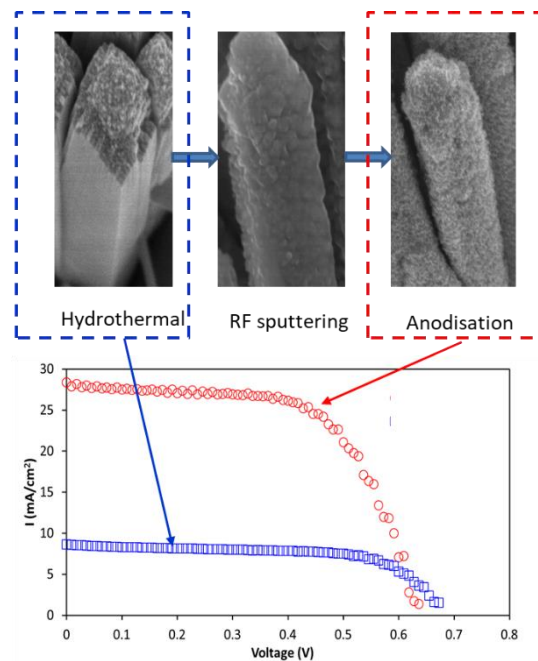

\*Keywords: DSSC, nanoflower, efficiency, porous,  $\text{TiO}_2$

\*References:

1. Ishak, N. N., Nayan, N., Ali, M. S. M., **Hasnan, M. M. I. M.**, Ahmad, M. K., Mustafa, M. K., ... & Mamat, M. H. (2021). Nano-Embedded High Performance Non-Toxic Solar Cell. *Science Proceedings Series*, 4(1), 42-46.
2. **Hasnan, M. M.**, Nayan, N., Hamed, N. K. A., Azman, Z., Ahmad, M. K., Ali, M. M., ... & Noor, I. M. (2021). Improvement of facile hydrothermal TiO<sub>2</sub> rutile nanorod-flower using second HiPIMS deposition for DSSC performance enhancement. *Optical Materials*, 117, 111149.

### 3.Short- Biography

**Full name:** Megat Muhammad Ikhsan Megat Hasnan

**Academic title:** Senior Lecturer ,Dr. Eng.

**Institute:** Faculty of Engineering, Universiti Malaysia Sabah, Malaysia



#### Biography

**M. M. I Megat Hasnan** received the Degree of Bachelor of Telecommunication Engineering and the Master Degree of Eng. Sci. in microelectromechanicals (MEMs) Design, from University of Malaya, Kuala Lumpur, Malaysia, in 2011 and 2015. He finished pursuing the Ph.D. Eng. Sci. in renewable energy at the same university in 2019. From 2011 to 2019, he was a Research Assistant with the Department of Electrical Engineering, Department of Mechanical Engineering and Department of Chemical Engineering at Faculty of Engineering University of Malaya, Malaysia. He had awarded for JASSO scholar fund for special research student at Tohoku University, Sendai Japan within his Ph.D studies for 4 month. Then, from September 2019 until Nov 2021, he had worked as a post-doctoral fellow in University Tun Hussein Onn Malaysia, Johor, Malaysia at Faculty of Electrical and Electronic Engineering and Microelectronic and Nanotechnology-Shamsuddin, Research Center (MiNT-SRC). Currently, he just starts as senior lecturer at Faculty of Engineering, Universiti Malaysia Sabah, Kota Kinabalu, Sabah, Malaysia. His research interest includes the development of energy harvester material and devices, smart sensors and green energy.

#### Contacts:

Email: megatikhsan@ums.edu.my

Phone: +6011-10944376

#### Selected Publicataions

1. Amin, N. A. A. M., Said, S. M., Salleh, M. F. M., Afifi, A. M., Ibrahim, N. M. J. N., **Hasnan, M. M. I. M.**, ... & Hashim, N. Z. I. (2022). Review of Fe-based spin crossover metal complexes in multiscale device architectures. *Inorganica Chimica Acta*, 121168.
2. Van Toan, N., Tuoi, T. T. K., Inomata, N., **Hasnan, M. M. I. M.**, Toda, M., Voiculescu, I., ... & Ono, T. (2022). Nanoengineered nanochannels for thermally ionic nanofluidic energy harvesting. *Energy Conversion and Management*, 264, 115760.
3. Bakri, A. S., Nafarizal, N., Abu Bakar, A. S., **Megat Hasnan, M. M. I.**, Raship, N. A., Wan Omar, W. I., ... & Aldalbahi, A. (2022). Electrical and structural comparison of (100) and (002) oriented AlN thin films deposited by RF magnetron sputtering. *Journal of Materials Science: Materials in Electronics*, 33(15), 12271-12280.

4. Haris, H., Muhammad, A. R., Tan, S. J., Markom, A. M., Harun, S. W., **Hasnan, M. M.** & Saad, I. (2022). Generation of Kelly and dip type sidebands soliton employing Topological insulator ( $\text{Bi}_2\text{Te}_3$ ) as saturable absorber. *Infrared Physics & Technology*, 123, 104154.
5. **Hasnan, M. M.**, Nordin, M. S., Nayan, N., Mohamad, K. A., Basri, N. F., Alias, A., ... & Noor, I. M. (2022). Optoelectronic properties comparison of 10 and 20 multi quantum wells  $\text{Ga}_0.952\text{In}_0.048\text{N}_0.016\text{As}_0.984/\text{GaAs}$  pin photodetector for 1.0  $\mu\text{m}$  wavelength. *Optical Materials*, 127, 112272.
6. Haris, H., Batumalay, M., Tan, S. J., Markom, A. M., Muhammad, A. R., Harun, S. W., ... **Hasnan, M. M.** & Saad, I. (2022). Mode-Locked YDFL Using Topological Insulator Bismuth Selenide Nanosheets as the Saturable Absorber. *Crystals*, 12(4), 489.
7. **Megat Muhammad Ikhsan Megat Hasnan**, Gim Pao Lim, Nafarizal Nayan, Chin Fhong Soon, Adyani Azizah Abd Halim, Mohd Khairul Ahmad, Suhana Mohd Said and Mohamed Sultan Mohamed Alif. The investigation of chlorpyrifos (Cpy) detection of PEDOT:PSS-MXene( $\text{Ti}_2\text{CTx}$ )-BSA-GO composite using P-ISFET reduction method. (2021), *Polymer Bulletin*.
8. Bakri, A. S., Nafarizal, N., Abu Bakar, A. S., **Megat Hasnan, M. M. I.**, Raship, N. A., Wan Omar, W. I., ... & Aldabahi, A. (2022). Electrical and structural comparison of (100) and (002) oriented AlN thin films deposited by RF magnetron sputtering. *Journal of Materials Science: Materials in Electronics*, 1-10.
9. **M.M.I. Megat Hasnan**, I.M. Noor, Nafarizal Nayan, Mohd Khairul Ahmad, Suhana Mohd Said, Mohd Faizul Mohd Sabri, Mohd Faiz bin Mohd Salleh, Mohamed Sultan Mohamed Ali, and Rosnah Mohd Zin, (2021), Enhancement of Spin Seebeck Effect of Reverse Spin crossover Fe(II) Micellar Charge Transport Using PMMA Polymer Electrolyte, *Journal Applied Organometallic Chemistry*.
10. Ibrahim, N. N., Said, S. M., Mainal, A., Sabri, M. M., Abdullah, N., **Hasnan, M. M.** ... & Salleh, M. M. (2021). INVESTIGATION OF IRON (III) IONIC STRUCTURAL COMPLEXES FOR SEEBECK COEFFICIENT ENHANCEMENT USING VARIATION OF LIGAND LENGTHS WITH EXTENDED  $\pi$ -CONJUGATED BIPYRIDYL LIGANDS. *Journal of Molecular Structure*, 130202.
11. Fatin Nor Ahmad, Yusmar Palapa Wijaya, Khairul Anuar Mohamad, **Megat Muhammad Ikhsan Megat Hasnan**, Morphology and Electrical Properties of Evaporated Pentacene Film with varying Thickness using Metal-Organic-Metal Structure, (2021) *Bulletin of Electrical Engineering and Informatic*
12. Che Hassan, Hazirah, Mohd Said, Suhana, **Megat Hasnan, Megat Muhammad Ikhsan**, Mohd Sabri, Mohd Faizul, Nik Ibrahim, Nik Muhd Jazli, Mohd Noor, Ikhwan Syafiq, Mohd Salleh, Mohd Faiz, Zakaria, Rozalina, Md. Noor, Nur Linahafizza, Abdullah, Norbani (2021), Ultra-high Seebeck coefficient of thermoelectrochemical cell through entropic optimisation of ligand length of Fe(II) spin-crossover (SCO) materials, *RSC Advances*.
13. Zulkifli Azman, Nafarizal Nayan **Megat Muhammad Ikhsan Megat Hasnan** Improvement of c-axis (002) AlN crystal plane by temperature assisted HiPIMS technique, (2021), *Microelectronics International*.
14. **Megat Muhammad Ikhsan Megat Hasnan**, Nafarizal Nayan, N.K.A. Hamed, Zulkifli Azman, Mohd Khairul Ahmad, Mohamed Sultan Mohamed Ali, I.M. Noor, Improvement of facile hydrothermal  $\text{TiO}_2$  rutile nanorod-flower (110) and (111) facets using second HiPIMS deposition of  $\text{TiO}_2$  at room temperature for DSSC performance enhancement. (2021), *Optical Materials*.
15. **M. M. I. Megat Hasnan**, Nafarizal Nayan, Mohd Khairul Bin Ahmad, Rosnah Mohd Zin, Soon Chin Fhong, Suhana Mohd Said, Mohamed Sultan Mohamed Ali, Mohd Faizul Mohd Sabri, and Mohd Faiz Mohd Salleh. Investigation of Si based thermoelectrochemical cells (TEC) towards semiconductor fabrication and process. (2021), *Semiconductor Science and Technology*.

The 3<sup>rd</sup> International Workshop on Engineering Physics, IC-MEMS-Sensors and  
Their Applications (3<sup>rd</sup>IWEMA2022)  
*November-25&26,2022; Ho Chi Minh City, Vietnam*

*Host by Faculty of Physics- Engineering Physic, University of Science,  
Vietnam National University- HCMC)  
and Ono Lab, Tohoku University, Sendai, Japan*

**PARALLEL SESSION: Invited talk**  
**(Session 2, code: IN-07)**

**1. Invited speaker**

Title of talk: **Developments in ECDM process during glass micromachining for MEMS packaging applications: process barriers and future opportunities**

Author (s): Tarlochan Singh

Institution (s): Lovely Professional University, Jalandhar

Country: India

Speaker: **Tarlochan Singh**

Academic title: **Assistant Professor**

E-mail: [tsingh.iitr@yahoo.com](mailto:tsingh.iitr@yahoo.com)

Handphone: + (91) 9464217483

**2. Abstract**

**Developments in ECDM process during glass micromachining for MEMS packaging applications: process barriers and future opportunities**

Tarlochan Singh  
Lovely Professional University, Jalandhar, India

Electrochemical discharge machining (ECDM) is an emerging micromachining process that can be employed to machine any kind of material regardless of their mechanical, electrical and thermal properties. It is a hybrid approach which integrates the features of electrochemical machining process and electro-discharge machining process. In recent

years, the process has been successfully utilized to machine the micro features on glass material for MEMS and microfluidic applications. In ECDM, the thermal energy liberated by the tool electrode due to the breakdown of gas film removes the material through melting and evaporation, and subsequent chemical etching. Instead of the several advantages (low setup and manufacturing cost), the process is not utilized at Industrial scale, and it is yet only tested and attempted to manufacture different features for MEMS and microfluidic applications at laboratory scale. Though, in recent times, several modifications have been carried out in direction to improve the process performance in terms of the development of new tools, electrolytes and the integration of new energies. However, up to certain level improvement has been reported, but still, there are several issues which need to be addressed in more detail.

Thus, in viewpoint of the above discussion, this talk is dedicated to discuss the barriers in ECDM process, limitations, developments carried out in ECDM process and future opportunities to improve the process performance in direction to get the accurate features for MEMS packaging applications. Moreover, this talk will also include the concepts to integrate several energies in ECDM process.

\*Keywords: ECDM, Micro-machining, Glass, MEMS packaging

\*Reference

1. lochan Singh\* and Akshay Dvivedi. "On performance evaluation of textured tools during micro channeling with ECDM." *Journal of Manufacturing Processes* 32 (2018): 699-713.
2. Tarlochan Singh\* and Akshay Dvivedi. "On energy channelization analysis for ECSM process during fabrication of microchannels in glass." *Materials and Manufacturing Processes* (2021): 1-5.
3. Tarlochan Singh\*, Julfekar Arab, and Pradeep Dixit. "A review on microholes formation in glass based substrates by electrochemical discharge drilling for MEMS applications." *Machining Science and Technology* 26(2) (2022): 276-337.
4. Sahil Sharma, Tarlochan Singh\*, and Akshay Dvivedi. "A Review on Developments in Electrolytes and their Feeding Methods for ECDM Process." *Silicon* (2022): 1-25.

### **3.Short-Biography**

**Full name: Tarlochan Singh, PhD.**

**Academic title:** Assistant Professor

**Institute:** Product and Industrial Design Department, Lovely Professional University, India.



## Biography

Tarlochan Singh is a Faculty Member in the School of Product and Industrial Design at Lovely Professional University (LPU), Jalandhar where he has been since March, 2022. Before joining to the LPU, Dr. Singh was an Institutional Post-doctoral fellow at Indian Institute of Technology Bombay, India. He received a B.Tech. in Mechanical Engineering from Punjab Technical University in 2011, and an M.Tech. from the Indian Institute of Technology Roorkee in 2013. He received Ph.D. in advanced manufacturing from the Indian Institute of Technology Roorkee in 2019. His present research interests includes the development of Advanced Manufacturing Processes for the machining of difficult to cut materials. Currently, research work is aimed towards the development of micro-fluidic devices on glass material with ECDM process. He has also working on ECDM process for the surface modification of ceramics and metals for MEMS and biomedical applications. He has published 24 peer-reviewed journal papers, 11 patents, one book, and three book chapters. Furthermore, Dr. Singh is also working on product design and development through human centric approaches.

## Contacts:

Email: [tsingh.iitr@yahoo.com](mailto:tsingh.iitr@yahoo.com)

Phone: +91-9464217483

## Original Journal Papers

1. **Tarlochan Singh\*** and Akshay Dvivedi. "Developments in electrochemical discharge machining: A review on electrochemical discharge machining, process variants and their hybrid methods." *International Journal of Machine Tools and Manufacture* 105 (2016): 1-13.
2. **Tarlochan Singh\***, Akshay Dvivedi, Anurag Shanu and Pradeep Dixit. "Experimental investigations of energy channelization behavior in ultrasonic assisted electrochemical discharge machining." *Journal of Materials Processing Technology* 293 (2021): 117084
3. **Tarlochan Singh\*** and Akshay Dvivedi\*. " On prolongation of discharge regime during ECDM by titrated flow of electrolyte." *International Journal of Advanced Manufacturing Technology* 107 (2020): 1819-1834.
4. **Tarlochan Singh\*** and Akshay Dvivedi. "On performance evaluation of textured tools during micro-channeling with ECDM." *Journal of Manufacturing Processes* 32 (2018): 699-713.
5. **Tarlochan Singh\*** and Akshay Dvivedi. "On pressurized feeding approach for effective control on working gap in ECDM." *Materials and Manufacturing Processes* 33, no. 4 (2018): 462-473
6. **Tarlochan Singh**, Akshay Dvivedi\* and Rajendra Kumar Arya. "Fabrication of micro-slits using W-ECDM process with textured wire surface: An experimental investigation on kerf overcut reduction and straightness improvement." *Precision Engineering* 59 (2019): 211-223. (**Editors' choice article**)
7. **Tarlochan Singh\***, Rajendra Kumar Arya and Akshay Dvivedi. "Experimental investigations into rotary mode electrochemical discharge drilling (RM-ECDD) of metal matrix composites." *Machining Science and Technology* 24 (2019): 1-32.
8. **Tarlochan Singh**, Ranjeet Singh Rathore, and Akshay Dvivedi\*. "Experimental investigations, empirical modeling and multi objective optimization of performance characteristics for ECDD with pressurized feeding method." *Measurement* 149 (2020): 107017.
9. **Tarlochan Singh\*** and Akshay Dvivedi. "Fabrication of micro holes in yttria stabilized zirconia through hybrid process of electrochemical discharge machining." *Ceramics International* 47 2021. 23677-23681.
10. **Tarlochan Singh\*** and Akshay Dvivedi. " Impact of gas film thickness on the performance of RM-ECDD process during machining of glass." *Materials and Manufacturing Processes*, 37 (6) (2021) 1-13.
11. Navin Kumar Jha, **Tarlochan Singh\***, Akshay Dvivedi and Shivanna Rajesha. "Experimental investigations into triplex hybrid process of GA-RDECDM during subtractive processing of MMC's." *Materials and Manufacturing Processes* 34, no. 3 (2019): 243-255.
12. Pawariya, Kapil, Akshay Dvivedi and **Tarlochan Singh\***. "On performance enhancement of electrochemical discharge trepanning (ECDT) process by sonication of tool electrode." *Precision*

*Engineering* 56 (2019): 8-19.

13. **Tarlochan Singh\*** and Akshay Dvivedi. "On energy channelization analysis for ECSM process during fabrication of microchannels in glass." *Materials and Manufacturing Processes* (2021): 1-5.
14. Dileep Kumar Mishra, **Tarlochan Singh\*** and Pradeep Dixit. "Cathode shape prediction for uniform electrochemical dissolution of array tools for ECDM applications." *Materials and Manufacturing Processes* (2021): 1-11.
15. **Tarlochan Singh**, Dileep Kumar Mishra and Pradeep Dixit. "Effect of pulse frequency and duty cycle on electrochemical dissolution behavior of multi-tip array tool electrode for reusability in the ECDM process" *Journal of Applied Electrochemistry* **52**, 667–682 (2022).
16. Vishnu Kant Bajpai, Harsh Pandey, **Tarlochan Singh**, and Pradeep Dixit. "Ultrasonic-assisted surface roughening of glass substrate to improve adhesion of electroless nickel seed layer in microsystems packaging." *Materials Letters* 316 (2022): 132033.
17. **Tarlochan Singh\***, Julfekar Arab, and Pradeep Dixit. "A review on microholes formation in glass-based substrates by electrochemical discharge drilling for MEMS applications." *Machining Science and Technology* 26(2) (2022): 276-337.
18. **Tarlochan Singh\***, Botcha Appalanaidu, and Akshay Dvivedi. "Improvement in energy channelization behaviour during micro hole formation in Y-SZ ceramic with magnetic field assisted ECSM process." *Measurement* 194 (2022): 111079.
19. Harsh Pandey, **Tarlochan Singh**, and Pradeep Dixit. "Formation of high aspect ratio through-glass vias by the combination of Ultrasonic micromachining and copper electroplating" *Journal of Manufacturing Processes* 82 (2022):569-584.
20. Sahil Sharma, **Tarlochan Singh\*** and Akshay Dvivedi. "Developments in tandem micro-machining processes to mitigate the machining issues at micron level: A systematic review, challenges and future opportunities." *Machining Science and Technology* (2022): 1-80.
21. Sahil Sharma, **Tarlochan Singh\***, and Akshay Dvivedi. "A Review on Developments in Electrolytes and their Feeding Methods for ECDM Process." *Silicon* (2022): 1-25.
22. **Tarlochan Singh\***, Sahil Sharma, Sarabjeet Singh Sidhu, Evgeny Sergeevich Shlykov, and Timur Rizovich Ablyaz. "Determination of Nanoindentation Behavior of HAZ on Glass Material Machined via ECSM Process through Simulation Approach." *Materials* 15, no. 17 (2022): 5870.
23. **Tarlochan Singh\***, Akshay Dvivedi, Sarabjeet Singh Sidhu, Evgeny Sergeevich Shlykov, Karim Ravilevich Muratov, and Timur Rizovich Ablyaz. "Energy Channelization Analysis of Rough Tools Developed by RM-MT-EDM Process during ECSM of Glass Substrates." *Materials* 15, no. 16 (2022): 5598.
24. Shailendra Chauhan, B. S. Pabla, Ravi Pratap Singh, Ramesh Singh, and **Tarlochan Singh**. "Study on surface integrity in turning of titanium using cryogenically treated CBN inserts." *Advances in Materials and Processing Technologies* (2022): 1-23.

The 3<sup>rd</sup> International Workshop on Engineering Physics, IC-MEMS-Sensors and  
Their Applications (3<sup>rd</sup>IWEMA2022)  
November-25&26,2022; Ho Chi Minh City, Vietnam

*Host by Faculty of Physics- Engineering Physic, University of Science,  
Vietnam National University- HCMC)  
and Ono Lab, Tohoku University, Sendai, Japan*

**PARALLEL SESSION: Invited talk**  
**(Session 2, code: IN-08)**

**1. Invited speaker**

Title of talk: Diamond wire wafer sawing technology: A way to reduce silicon kerf and wafer thickness for the applications of Si MEMS and solar cells

Author (s): Halubai Sekhar

Institution (s): Nagoya Institute of Technology, Super Photon ring8 (Spring8)

Country: Japan

Speaker: Halubai Sekhar

Academic title: Senior researcher

E-mail: halubai.sekhar@nitech.ac.jp

Handphone: +81-9068714685

**2. Abstract**

Diamond wire wafer sawing technology: A way to reduce silicon kerf and wafer thickness for the applications of Si MEMS and solar cells

Halubai Sekhar

Structural Physics Laboratory, Nagoya Institute of Technology and SPring8, Japan.

\*Email: halubai.sekhar@nitech.ac.jp; halubaisekhar@gmail.com;

\*Keywords : Diamond wire; thin silicon wafer; silicon kerf; crack

To reduce the cost of silicon (Si) wafer preparation for photovoltaics (PV) and microelectromechanical systems (MEMS) use, wafer sawing industry challenging on twin goals in multi-wire saw to reduce the Si kerf (saw dust) per wafer and to saw thinner wafers. Silicon is the base material (for single junction or multi junction (Si as bottom cell)), which accounts for approximately 50% of modules cost. Therefore, there is a huge

room for reducing the cost of solar cells using thin Si wafers in single or multi (tandem) junction solar cells. There are some limitations on wafer thickness because wafers easily fracture due to their brittle nature. In physical slicing, cracks present on the surface or subsurface of the wafer. They have the strong impact on the production yields. So one has to cut Si brick into thin wafers without compromising its production yields. In my presentation, I will talk about the challenges associated with cutting brittle Si bricks into thin (120  $\mu\text{m}$ ) wafers using thin diamond wires with a slicing yields of above 96%[1 - 5]. Which allows to reduce the production cost of first generation Si crystalline solar cells upto 30% at the production level.



Fig. (a) shows a SEM image of a diamond wire which we have developed in order to improve wafer-slicing yield, (b) as-sawn thin wafers sticking to a support board and (c) the demonstration showing that the etched thin Si (100  $\mu\text{m}$ ) wafer can bend largely due to almost crack-free surfaces [1 - 5].

**Acknowledgment:** The present work performed at Fukushima Renewable Energy Institute, AIST, Japan. The author thanks to Dr. T. Fukuda and Dr. H. Takato for their kind help and support.

#### Reference

1. H. Sekhar et al. Japanese Journal of Applied Physics 57, 126501 (2018).
2. H. Sekhar et al. Japanese Journal of Applied Physics 57, 08RB08 (2018).
3. H. Sekhar et al. Japanese Journal of Applied Physics 57, 095501 (2018).
4. H. Sekhar et al. Material Science in Semiconductor Processing 119, 105209 (2020)
5. H. Sekhar et al. Material Science in Semiconductor Processing 105, 104751 (2020).

### 3. Short- Biography

**Full name:** Dr. Halubai Sekhar.

**Academic title:** Research Assistant Professor and Invited Researcher

**Institute:** Nagoya Institute of Technology and Super Photon ring (SPring8), Japan



Contact:

Email:

halubai.sekhar@nitech.ac.jp

Phone: +81-9068714685

**Dr. Halubai Sekhar** received his master (M.Sc) degree in physics in 2004 from the Sri Venkateswara University and doctoral (Ph.D) degree in physics in 2013 from the University of Hyderabad, India. In doctoral course, he was developed several fascinating nonlinear optical (bulk and nano) materials for the applications of optical sensors (limiters). He came to Japan in May/2013 as a Post-doctoral fellow at Tohoku University, worked with Prof. Seiji Samukawa and gained tremendous knowledge working on dry etching of Silicon and AlGaIn/GaN for the application of Si quantum dot solar cells, Si MEMS and AlGaIn/GaN HEMT. In the mid of 2014, he joined as a specially appointed research scientist at National Institute of Advanced Industrial Science of Technology (AIST) and succeed to saw thin (120  $\mu\text{m}$ ) mono-crystalline silicon wafers having high mechanical strength using thin (90  $\mu\text{m}$ ) diamond wires with slicing yields above >96% for photovoltaics (PV) use. The diamond wire silicon wafer sawing technology transferred to home grown wafer sawing vendors, which allows to reduce the production cost up to 30% in Si MEMS and Si photovoltaics. He has published 30 peer-reviewed journal papers and presented more than 60 conferences at domestic and international level. His current research includes in a broad range from bulk to quantum materials, to explore its applications for the betterment of human society. At present he is working on 3D imaging of ordered and dis-ordered materials using third generation synchrotron radiation at SPring8, Japan.

### Original Journal Papers

1. **H. Sekhar**, T. Fukuda, T. Kubota, M.M. Rahman, H. Takato M. Kondo and S. Samukawa, “Advanced damage-free neutral beam etching technology to texture Si wafer with honeycomb pattern for broadband light trapping in photovoltaics” (Journal of Materials Science: Materials in Electronics) 32 (23), 27449-27461 (2021).
2. **Halubai Sekhar**, Tetsuo Fukuda, Katsuto Tanahashi, Hidetaka Takato Hiromichi Ono, Yoshiyuki Sampei, and Tsubasa Kobayashi “Mechanical-strength problem of thin silicon wafers (120 and 140 $\mu\text{m}$ ) cut with thinner diamond wires (Si kerf 120  $\rightarrow$  100  $\mu\text{m}$ )” Material Science in Semiconductor Processing 119, 105209 (2020).
3. **Halubai Sekhar**, Tetsuo Fukuda, Katsuto Tanahashi, Hidetaka Takato, “The impact of silicon brick polishing on thin (120  $\mu\text{m}$ ) silicon wafer sawing yields and fracture strengths in diamond-wire sawing” Material Science in Semiconductor Processing 105, 104751 (2020).
4. M. M. Rahman, S. Hossain, **H. Sekhar**, and H. A. Begum, “Development of Pt nanoparticles coated transparent conductive oxide (TCO) Electrode: optimization of deposition condition” J. Critical Reviews 7 (2020) 4137.
5. **Halubai Sekhar**, Tetsuo Fukuda, Yasuhiro Kida, Katsuto Tanahashi, and Hidetaka Takato, “The impact of damage etching on fracture strength of diamond wire sawn monocrystalline silicon wafers for PV use” Japanese Journal of Applied Physics 57, 126501 (2018).
6. **Halubai Sekhar**, Tetsuo Fukuda, Katsuto Tanahashi, Katsuhiko Shirasawa, Hidetaka Takato, Kazuya Ohkubo, Hiromichi Ono, Yoshiyuki Sampei, Tsubasa Kobayashi, “The impact of subsurface damage on the fracture strength of diamond-wire-sawn monocrystalline silicon wafers” Japanese Journal of Applied Physics 57, 08RB08 (2018). (Selected as most read article for the year 2018).
7. **Halubai Sekhar**, Tetsuo Fukuda, Katsuto Tanahashi, Katsuhiko Shirasawa, Hidetaka Takato, Kazuya Ohkubo, Hiromichi Ono, Yoshiyuki Sampei, Tsubasa Kobayashi, “The impact of saw mark directions on the fracture strength of thin (120  $\mu\text{m}$ ) monocrystalline silicon wafers for photovoltaic cells” Japanese Journal of Applied Physics 57, 095501 (2018).
8. **Halubai Sekhar**, Tetsuo Fukuda, Katsuto Tanahashi, Katsuhiko Shirasawa, Hidetaka Takato, Kazuya Ohkubo, Hiromichi Ono, Yoshiyuki Sampei, and Tsubasa Kobayashi, “The impact of

wafer thickness (210 and 140  $\mu\text{m}$ ) for photovoltaic use on the fracture strength” 35th European Photovoltaic Solar Energy Conference and Exhibition-2018, Brussels, Belgium.

9. **H. Sekhar**, T Kubota, Y Kida, T Fukuda, K Tanahashi, H Takato, M Kondo, S Samukawa “Nano holes on micro pyramids; broadband optical light trapping in thin wafer based Si (< 100  $\mu\text{m}$ ) solar cells” Nanotechnology (IEEE-NANO) 415-418 (2016).
10. Mohammad Maksudur Rahman, Ming-Yi Lee, Yi-Chia Tsai, Akio Higo, **Halubai Sekhar**, Makoto Igarashi, Mohd Erman Syazwan, Yusuke Hoshi, Kentarou Sawano, Noritaka Usami, Yiming Li, Seiji Samukawa “Impacts of Silicon Quantum Dot Superlattice and Quantum Well Structure as Intermediate Layer on p-i-n Silicon Solar Cells” Progress in Photovoltaics: Research and Applications 24, 774–780 (2016).
11. M. M. Rahman, Akio Higo, **Halubai Sekhar**, Takeru Okada, Mohd Erman Syazwan, Yusuke Hoshi, Noritaka Usami, and Seiji Samukawa “Effect of Passivation Layer Grown by Atomic Layer Deposition and Sputtering Processes on Si Quantum Dot Super lattice to Generate High Photocurrent for High-Efficiency Solar Cells” Japanese Journal of Applied Physics 55 (3), 032303 1-6 (2016).
12. **H. Sekhar**, Y. Rakesh Kumar and D. Narayana Rao “Observation of confinement effects through linear and nonlinear absorption spectroscopy in cuprous oxide” IOP: Materials Science and Engineering 73 (2015) 012078.
13. **H. Sekhar**, Y. Rakesh Kumar and D. Narayana Rao “Preparation, structural and linear optical properties of Zn doped CdS nanopowders” IOP: Materials Science and Engineering 73 (2015) 012079.
14. Nguyen Van Toan, Tomohiro Kubota, **Halubai Sekhar**, Seiji Samukawa and Takahito Ono “Fabrication and Evaluation of Silicon Micromechanical Resonator using Neutral Beam Etching Technology” IEEE NEMS (2014) (Awarded as a best student research).
15. Nguyen Van Toan, Tomohiro Kubota, **Halubai Sekhar**, Seiji Samukawa and Takahito Ono “Mechanical quality factor enhancement in silicon micromechanical resonator by low-damage process using neutral beam etching technology” J. Micromech. Microeng 24 (2014) 085005.
16. P. Harshavardhan Reddy, **H. Sekhar** and D. Narayana Rao “Picosecond nonlinear optical properties of cuprous oxide with different nano-morphologies” Pramana J. Physics 82 (2014) 32.
17. **H. Sekhar** and D. Narayana Rao “Preparation and characterization of heat treated Zn doped CdS powders and it’s Up and down conversion luminescence” Science of Advanced Materials 5 (2013) 1.
18. **H. Sekhar** and D. Narayana Rao “Stokes and anti-Stokes luminescence in heat treated CdS nanopowders” J. Phys. Chem. C, 117 (2013) 2300.
19. **H. Sekhar**, G. Trivikrama Rao, P. Harshavardhan Reddy and D. Narayana Rao “Preparation, structural and its enhanced green up-conversion luminescence in heat treated rare earth doped CdMnS nano powders” J. Alloys and Compounds, 562 (2013) 38.
20. **H. Sekhar** and D. Narayana Rao “Preparation, structural and linear optical properties of Zinc Sillenite ( $\text{Bi}_{12.66}\text{Zn}_{0.33}\text{O}_{19.33}$ ) Nanocrystals” Journal of Materials Science: Materials in Electronics; 24 (2013) 1569).
21. **H. Sekhar** and D. Narayana Rao “Preparation, characterization and nonlinear absorption studies of cuprous oxide nano clusters, micro cubes and micro particles” J. Nanoparticle Research 14 (2012) 976.
22. **H. Sekhar** and D. Narayana Rao “Spectroscopic studies on  $\text{Fe}^{3+}$  doped CdS nanopowders prepared by simple co-precipitation method” J. Alloys and Compounds 517 (2012) 103. I
23. **H. Sekhar** and D. Narayana Rao “Spectroscopic studies on Zn doped CdS nanopowders prepared by simple co-precipitation method” J. Material Science 47 (2012) 1964.
24. **H. Sekhar**, P. Prem Kiran and D. Narayana Rao “Structural, linear and enhanced third- order nonlinear optical properties of  $\text{Bi}_{12}\text{SiO}_{20}$  nanocrystals”. Materials Chemistry and Physics 130 (2011) 113.

The 3<sup>rd</sup> International Workshop on Engineering Physics, IC-MEMS-Sensors and  
Their Applications (3<sup>rd</sup>IWEMA2022)  
November-25&26,2022; Ho Chi Minh City, Vietnam

*Host by Faculty of Physics- Engineering Physic, University of Science ,  
Vietnam National University- HCMC)  
and Ono Lab, Tohoku University, Sendai, Japan*

**PARALLEL SESSION**

**(Session 3, code: IN-09)**

-----

**1. Invited speaker**

Title of talk: An improvement of Tunnel Oxide thickness in the virtual fabrication process for a 65 nm Nanocrystal Floating-Gate MOS

Author (s): Thanh Dang Cong, Phuc Ton That Bao, Trang Hoang

Institution (s): Department of Electronics Engineering, Ho Chi Minh City University of Technology (HCMUT), Vietnam National University

Country: Vietnam

Speaker: Trang Hoang

Academic title: Assoc.Prof, Ph.D

E-mail: hoangtrang@hcmut.edu.vn

Handphone: +84 988071579

**2. Abstract**

Floating-gate MOS lies at the heart of many aspects of semiconductor applications such as analog mixed-signal, and neural networks, especially in non-volatile memories. The purpose of this paper was to improve the tunneling gate oxide thickness by designing the new structure called Nanocrystal Floating-gate MOS that has a sea of silicon quantum dots as the storage charge gate. In this work, a two-dimensional virtual fabrication process was proposed to fully fabricate and characterize the 65 nm technology node by using the TCAD tools. Regarding the results, while the fabrication process solves the limitation of the tunnel oxide layer thickness with the value is just 6 nm, the performance of the MOS has been considered such as 3 V of the memory window,  $I_{ON}/I_{OFF}$  ratio is 124.265, the speeds of the Write and Erase are 50 ms and 80 ms, respectively. In addition to this, the input voltage is compatible with other works, with a value of 12V for the control gate.

\*Keywords: Floating-gate MOS, Nanocrystal Nonvolatile Memory, Flash memory cell, FG MOS silicon quantum dots, Tunneling effects, CMOS technology, Gate leakage current, TCAD tool.

\*References:

Wang S, He C, Tang J, Lu X, Shen C, Yu H, Du L, et al., Nonvolatile memory: New floating gate memory with excellent retention characteristics (adv. electron. mater. 4/2019), *Adv Electron Mater* 2019;5 (4): 1970018.

Agarwal S, Garland D, Niroula J, Jacobs-Gedrim RB, Hsia A, Van Heukelom MS, Fuller E, Draper B, Marinella MJ. Using floating-gate memory to train ideal accuracy neural networks. *IEEE J Explorat Solid-State Comput Dev Circ* 2019;5 (1):52–7.

Dabhi C.T, Patil G.C. Underlap channel silicon-on-insulator quantum dot floating-gate mosfet for low-power memory applications. *J Comput Electron* 2016; 15(4):1563–9.

R. Dhavse, K. Prashant, C. Dabhi, A. Darji, R. Patrikar, Fabrication and investigation of low-voltage programmable flash memory gate stack, in: *Proceedings of the International Conference on Microelectronics, Computing & Communication Systems*, Springer, 2018, pp. 35–49.

De Blauwe J. Nanocrystal nonvolatile memory devices. *IEEE Trans Nanotechnol* 2002;1(1):72–7. doi: <https://doi.org/10.1109/TNANO.2002.1005428>.

Hamzah A, Ahmad H, Tan MLP, Alias NE, Johari Z, Ismail R. Scaling challenges of floating gate non-volatile memory and graphene as the future flash memory device: a review. *J Nanoelectron Optoelectron* 2019;14(9):1195–214.

S.N. Keeney, Dielectric scaling challenges and approaches in floating gate non-volatile memories, in: *Proceedings-electrochemical society*, 2004, pp. 151–158.

Wunderlich RB, Adil F, Hasler P. Floating gate-based field programmable mixed-signal array. *IEEE Trans Very Large Scale Integr (VLSI) Syst* 2012;21 (8):1496–505.

Kim T, Park K, Jang T, Baek M-H, Song YS, Park B-G. Input-modulating adaptive neuron circuit employing asymmetric floating-gate mosfet with two independent control gates. *Solid-State Electron* 2020; 163:107667.

Saheb Z, El-Masry EI. Modelling of direct tunneling gate leakage current of floating gate cmos transistor in sub 100 nm technologies. *Analog Integr Circ Signal Process* 2015;84(1):67–73.

The international technology roadmap for semiconductors (itrs), 2013.

Saheb Z, El-Masry E. Practical simulation model of floating-gate mos transistor in sub 100nm technologies. *Int J Electr, Comput, Energetic, Electron Commun Eng* 9 (8).

Tseng JM, Pedron T. A new method to extract gate coupling ratio and oxide trapped charge in flash memory cell. *Microelectron Eng* 2006;83(2):218–20.

Chiu S, Xu Y, Ji X, Liao Y, Wu F, Yan F. An advanced tunnel oxide layer process for 65 nm nor floating-gate flash memories. *Semiconductor Sci Technol* 2015;30 (10):105032.

Chiu S, Xu Y, Ji X, Yan F. Investigation of impact of post-metallization annealing on reliability of 65 nm nor floating-gate flash memories. *Solid-State Electron* 2016; 126:125–9.

D. Shum, J. Power, R. Ullmann, E. Suryaputra, K. Ho, J. Hsiao, C. Tan, W. Langheinrich, C. Bukethal, V. Pissors, et al., Highly reliable flash memory with self-aligned split-gate cell embedded into high performance 65nm cmos for automotive & smartcard applications, in *2012 4th IEEE International Memory Workshop*, IEEE, 2012, pp. 1–4.

Hamzah A, Alias NE, Ismail R. Low-voltage high-speed programming gate-all-around floating gate memory cell with tunnel barrier engineering. *Japan J Appl Phys* 2018;57(6S3):06KC02.

A. Misra, H. Kalita, M. Waikar, A. Gour, M. Bhaisare, M. Khare, M. Aslam, A. Kottantharayil, Multilayer graphene as charge storage layer in floating gate flash memory, in 2012 4th IEEE International Memory Workshop, IEEE, 2012, pp. 1–4.

Bertolazzi S, Krasnozhon D, Kis A. Nonvolatile memory cells based on mos<sub>2</sub>/graphene heterostructures. *ACS nano* 2013;7(4):3246–52.

Kang D, Shin H. Improving the cell characteristics using arch-active profile in nand flash memory having 60 nm design-rule. *Solid-state Electron* 2010;54 (11):1263–8.

G. Servalli, D. Brazzelli, E. Camerlenghi, G. Capetti, S. Costantini, C. Cupeta, D. DeSimone, A. Ghetti, T. Ghilardi, P. Gulli, et al., A 65nm nor flash technology with 0.042/spl mu/m/sup 2/cell size for high performance multilevel application, in: IEEE International Electron Devices Meeting, 2005. IEDM Technical Digest., IEEE, 2005, pp. 849–852.

D. Wellekens, P. Blomme, M. Rosmeulen, T. Schram, A. Cacciato, I. Debusschere, S. Van Aerde, J. Van Houdt, An ultra-thin hybrid floating gate concept for sub 20nm nand flash technologies, in 2011 3rd IEEE International Memory Workshop (IMW), IEEE, 2011, pp. 1–4.

Ali T, Polakowski P, Büttner T, Kämpfe T, Rudolph M, Pätzold B, Hoffmann R, Czernohorsky M, Kühnel K, Steinke P, et al. Theory and experiment of antiferroelectric (afe) si-doped hafnium oxide (hso) enhanced floating-gate memory. *IEEE Trans Electron Dev* 2019;66(8):3356–64.

Larcher L, Pavan P, Pietri S, Albani L, Marmiroli A. A new compact dc model of floating gate memory cells without capacitive coupling coefficients. *IEEE Trans Electron Dev* 2002;49(2):301–7.

B.S. Kalyan, B. Singh, Design and simulation equivalent model of floating gate transistor, in 2015 Annual IEEE India Conference (INDICON), IEEE, 2015, pp. 1–6.

Cao W, Kang J, Bertolazzi S, Kis A, Banerjee K. Can 2d-nanocrystals extend the lifetime of floating-gate transistor based nonvolatile memory? *IEEE Trans Electron Dev* 2014;61(10):3456–64.

J. An, J.-L. Maurice, V. Depauw, P.R. i Cabarrocas, W. Chen, Impact of pecvd-prepared interfacial si and sige layers on epitaxial si films grown by pecvd (200 °c) and apcvd (1130 °c), *Applied Surface Science* 546 (2021) 149056.

H. Kim, K. Lu, Y. Liu, H.S. Kum, K.S. Kim, K. Qiao, S.-H. Bae, S. Lee, Y.J. Ji, K.H. Kim, et al., Impact of 2d–3d heterointerface on remote epitaxial interaction through graphene, *ACS nano*.

Jaeger RC. Introduction to microelectronic fabrication, Addison-Wesley Longman Publishing Co., Inc., 2002.

Baker RJ. CMOS: circuit design, layout, and simulation. John Wiley & Sons; 2019.

Lee M, Cho S, Lee N, Kim J. Radiation-tolerance analysis of i-gate n-mosfet according to isolation oxide module in the cmos bulk process. *Microelectron Eng* 2018; 200:45–50.

Garetto D, Dornel E, Hniki S, Rideau D, Clark W, Schmid A, Tavernier C, et al. Analytical and compact models of the ono capacitance in embedded nonvolatile flash devices. In: European Solid-State Devices and Technologies Conference, ESSDERC/ESSCIRC Fringe Poster Session, no. CONF; 2009.

Chen H, Zhou Y, Han ST. Recent advances in metal nanoparticle-based floating gate memory, *Nano Select*.

### 3. Short- Biography

**Full name:** Trang Hoang

Associate Professor, Ph.D, Senior lecturer

**Position:** Dean of Graduate School of Ho Chi Minh City University of Technology, VNU-HCM, Vietnam

**Address:**

268 Ly Thuong Kiet Str., District 10, Ho Chi Minh city, Vietnam

**Contact:**

- Handhone: +84 988071579

- Email address: [hoangtrang@hcmut.edu.vn](mailto:hoangtrang@hcmut.edu.vn)



Trang Hoang was born in Nha Trang city, Vietnam. He received the Bachelor of Engineering, and Master of Science degree in Electronics-Telecommunication Engineering from Ho Chi Minh City University of Technology in 2002 and 2004, respectively. He received the Ph.D. degree in Microelectronics-MEMS from CEA-LETI and University Joseph Fourier, France, in 2009. From 2009–2010, he did the postdoctorate research in Orange Lab-France Telecom. Since 2010, he has been a lecturer, promoted to Associate Professor in 2014, at Faculty of Electricals–Electronics Engineering, Ho Chi Minh City University of Technology. His field of research interest is in the domain of ASIC/FPGA implementation for Speech Recognizer, IC architecture, MEMS, fabrication, security router, algorithms, AI, quantum computing.

#### 1. Research Areas:

- ASIC/FPGA architecture for high performance applications,
- Virtual micro-fabrication for IC and MEMS,
- AI in router and electronics applications, quantum computing.

#### 2. Faculty/Department/Laboratory

- Department of Electronics Engineering
- Faculty of Electrical-Electronics
- IC design lab, Electronics Engineering lab.

#### 3. Research Activities

- Principal Investigators for 3 Key projects at State level, 3 projects with industries, 2 projects at city level, 3 projects at university, ministry levels.
- 15 IPs, related to electronics engineering.
- More than 90 publication papers. H-index: 9.
- 4 books in Embedded system, MEMS, IC design.

The 3<sup>rd</sup> International Workshop on Engineering Physics, IC-MEMS-Sensors and  
Their Applications (3<sup>rd</sup>IWEMA2022)  
*November-25&26,2022; Ho Chi Minh City, Vietnam*

*Host by Faculty of Physics- Engineering Physic, University of Science,  
Vietnam National University- HCMC)  
and Ono Lab, Tohoku University, Sendai, Japan*

**PARALLEL SESSION: Invited talk**  
**(Session 3, code: IN-10)**

**1. Invited speaker**

Title of talk: Hybrid Neuron Circuit with Floating-body Positive Feedback Field Effect Transistor for Low Power operation

Author (s): Min-Woo Kwon

Institution (s): Gangneung-Wonju National University

Country: South Korea

Speaker: Min-Woo Kwon

Academic title: Assistant Professor

E-mail: [mwkwon@gwnu.ac.kr](mailto:mwkwon@gwnu.ac.kr)

Handphone: .010-4723-8849

**2. Abstract**

The most important aspect of an artificial neuron circuit is energy consumption. An analog neuron circuit has a critical problem in that the energy consumption in the steady-state due to a short-circuit current in the first inverter is quite large. In this study, we first demonstrated an adaptive neuron circuit with a dual-gate positive feedback field-effect transistor (FBFET) and fabricated a neuron circuit by co-integrating the FBFET and a complementary metal-oxide semiconductor (CMOS) in a chip. The fabricated FBFET has an extremely low sub-threshold slope of less than 0.5 mV/dec and a low off current. By adjusting the second gate bias, it is possible to implement spike-frequency adaptive characteristics in the neuron circuit. The proposed neuron circuit with the FBFET can significantly reduce the power dissipation. In the neuron circuit, a short-circuit current is suppressed by adopting the FBFET in the first inverter. In a modified inverter with the FBFET, more than 50% total energy consumption

was reduced by the FBFET. We implemented the modified inverter in which the FBFET is connected in parallel with an N-channel metal-oxide semiconductor. Finally, we analyzed the fabricated FBFET neuron circuit operation and power consumption compared to a conventional CMOS neuron circuit

\*Keywords (5): integrate-and-fire neuron circuit, low power, positive feedback field-effect transistor, short-circuit current, spike-frequency adaptation

\*References:

[1]. M.-W. Kwon, M.-H. Beak, S. Hwang, K. Park, T. Jang, J. Lee, S. Cho, and B.-G. Park. "Integrate-and-fire neuron circuit using positive feedback field effect transistor for low power operation." *Journal of Applied Physics* 124.15:152107, 2018.

[2]. M.-W. Kwon, K. Park, M. Baek, J. Lee and B.-G. Park, "A Low-Energy High-Density Capacitor-Less I&F Neuron Circuit Using Feedback FET Co-Integrated With CMOS," in *IEEE Journal of the Electron Devices Society*, vol. 7, pp.1080-1084, 2019.

### 3. Short- Biography

Min-Woo Kwon received B.S. and Ph. D. degrees in department of Electrical and Computer Engineering from Seoul National University (SNU) in 2012 and 2019, respectively. From 2019 to 2021, he worked at the Samsung semiconductor Laboratories, where he contributed to the development of 1x nm DRAM cell transistor and its characterization. In 2021, he joined Gangneung-Wonju National University (GWNU) as an assistant professor in the Department of Electric Engineering, where he is currently a professor.



His current research interests include the design and fabrication of neuromorphic device (memristor synaptic device, Neuron circuit), steep switching device (FBFET), DRAM cell transistors and 2-dimensional nano-materials.

The 3<sup>rd</sup> International Workshop on Engineering Physics, IC-MEMS-Sensors and  
Their Applications (3<sup>rd</sup>IWEMA2022)  
November-25&26,2022; Ho Chi Minh City, Vietnam

*Host by Faculty of Physics- Engineering Physic, University of Science ,  
Vietnam National University- HCMC)  
and Ono Lab, Tohoku University, Sendai, Japan*

**PARALLEL SESSION**

**(Session 3, code: IN-11)**

-----

**1. Invited speaker**

Title of talk: **Binary memristor crossbar architecture based neural networks for speech recognition.**

Author (s): Vo Minh Huan

Institution (s): Ho Chi Minh University of Technology and Education

Country: Viet Nam

Speaker: Vo Minh Huan

Academic title: Associate professor, Senior lecturer

E-mail: huanvm@hcmute.edu.vn Handphone: 0909437522

**2. Abstract**

The neural network architecture is widely used in many research fields such as speed recognition, image recognition, and robot control. Normally, the CMOS transistors are implemented on hardware neuron architectures. However, the power consumption and transistor size scaling still have limitations, so far. In this paper, a binary memristor crossbar architecture based on multilayer neural networks is proposed in the speech recognition application. Here, the memristor crossbar circuit acts as the weights of the neural network combined with the activation function circuit to determine the output. In the proposed crossbar architecture, the weights are arranged diagonally and divided into 2 arrays according to positive and negative weights. A speech recognition application for 5 vowels is implemented using the proposed architecture. The result shows that the average recognition rate achieves from 94 percent to 96.6 percent over 1000 audio samples. A

statistical table shows that the recognition rate and the number of the memristors increase correspondingly to the number of used bits. From the Monte Carlo simulation, the recognition rate of the proposed binary memristor crossbar is decreased slightly from 94 percent to 93.7 percent, while the memristance variation is increased from 1 percent to 15 percent.

\*Keywords: Pattern recognition, memristors, neural network, neural network hardware, speech recognition

\*References:

1. Waibel, T. Hanazawa, G. Hinton, K. Shikano, and K. J. Lang, "Phoneme recognition using time-delay neural networks," *IEEE Trans. Acoust. Speech Signal Process.*, vol. 37, no. 3, pp. 328–339, Mar. 1989. doi: 10.1109/29.21701.
2. H. A. Rowley, S. Baluja, and T. Kanade, "Neural network-based face detection," *IEEE Trans. Pattern Anal. Mach. Intell.*, vol. 20, no. 1, pp. 23–38, Jan. 1998. doi: 10.1109/34.655647.
3. R. Fierro and F. L. Lewis, "Control of a nonholonomic mobile robot using neural networks," *IEEE Trans. Neural Netw.*, vol. 9, no. 4, pp. 589–600, Jul. 1998. doi: 10.1109/72.701173.
4. J. B. Lont and W. Guggenbuhl, "Analog CMOS implementation of a multilayer perceptron with nonlinear synapses," *IEEE Trans. Neural Netw.*, vol. 3, no. 3, pp. 457–465, May 1992. doi: 10.1109/72.129418.
5. A. J. Montalvo, R. S. Gyurcsik, and J. J. Paulos, "Toward a generalpurpose analog VLSI neural network with on-chip learning," *IEEE Trans. Neural Netw.*, vol. 8, no. 2, pp. 413–423, Mar. 1997. doi: 10.1109/72.557695.
6. T. Shima, T. Kimura, Y. Kamatani, T. Itakura, Y. Fujita, and T. Iida, "Neuro chips with on-chip back-propagation and/or Hebbian learning," *IEEE J. Solid-State Circuits*, vol. 27, no. 12, pp. 1868–1876, Dec. 1992. doi: 10.1109/4.173117.
7. L. Gatet, H. Tap-Beteille, and F. Bony, "Comparison Between Analog and Digital Neural Network Implementations for Range-Finding Applications," *IEEE Trans. Neural Netw.*, vol. 20, no. 3, pp. 460–470, Mar. 2009. doi: 10.1109/TNN.2008.2009120
8. W. H. Lee and P. Mazumder, "Motion Detection by Quantum-DotsBased Velocity-Tuned Filter," *IEEE Trans. Nanotechnol.*, vol. 7, no. 3, pp. 355–362, May 2008. doi: 10.1109/TNANO.2007.915019
9. P. Mazumder, S. Li, and I. E. Ebong, "Tunneling-Based Cellular Nonlinear Network Architectures for Image Processing," *IEEE Trans. Very Large Scale Integr. VLSI Syst.*, vol. 17, no. 4, pp. 487–495, Apr. 2009. doi: 10.1109/TVLSI.2009.2014771
10. L. Chua, "Memristor-The missing circuit element," *IEEE Trans. Circuit Theory*, vol. 18, no. 5, pp. 507–519, Sep. 1971. doi: 10.1109/TCT.1971.1083337.
11. D. B. Strukov, G. S. Snider, D. R. Stewart, and R. S. Williams, "The missing memristor found," *Nature*, vol. 453, no. 7191, pp. 80–83, May 2008. doi: <https://doi.org/10.1038/nature06932>.
12. H. Zhao et al., "Memristor-based signal processing for edge computing," in *Tsinghua Science and Technology*, vol. 27, no. 3, pp. 455–471, June 2022, doi: 10.26599/TST.2021.9010043.
13. X. Yang, B. Taylor, A. Wu, Y. Chen and L. O. Chua, "Research Progress on Memristor: From Synapses to Computing Systems," in *IEEE Transactions on Circuits and Systems I: Regular Papers*, vol. 69, no. 5, pp. 1845–1857, May 2022, doi: 10.1109/TCSI.2022.3159153.
14. T. Van Nguyen, J. An and K. -S. Min, "Comparative Study on Quantization-Aware Training of Memristor Crossbars for Reducing Inference Power of Neural Networks at The Edge," 2021 *International Joint Conference on Neural Networks (IJCNN)*, 2021, pp. 1–6, doi: 10.1109/IJCNN52387.2021.9533834.
15. H. Ran, S. Wen, S. Wang, Y. Cao, P. Zhou and T. Huang, "Memristor-Based Edge Computing of ShuffleNetV2 for Image Classification," in *IEEE Transactions on Computer-Aided Design of Integrated Circuits and Systems*, vol. 40, no. 8, pp. 1701–1710, Aug. 2021, doi: 10.1109/TCAD.2020.3022970.

16. S. N. Truong, K. V. Pham, W. Yang, and K. Min, "Sequential Memristor Crossbar for Neuromorphic Pattern Recognition," *IEEE Trans. Nanotechnol.*, vol. 15, no. 6, pp. 922–930, Nov. 2016. doi: 10.1109/82.222818.
17. S. P. Adhikari, H. Kim, R. K. Budhathoki, C. Yang, and L. O. Chua, "A Circuit-Based Learning Architecture for Multilayer Neural Networks With Memristor Bridge Synapses," *IEEE Trans. Circuits Syst. Regul. Pap.*, vol. 62, no. 1, pp. 215–223, Jan. 2015. doi: 10.1109/TCSI.2014.2359717.
18. D. Soudry, D. D. Castro, A. Gal, A. Kolodny, and S. Kvatinsky, "Memristor-Based Multilayer Neural Networks With Online Gradient Descent Training," *IEEE Trans. Neural Netw. Learn. Syst.*, vol. 26, no. 10, pp. 2408–2421, Oct. 2015. doi: 10.1109/TNNLS.2014.2383395.
19. L. Muda, M. Begam, and I. Elamvazuthi, "Voice Recognition Algorithms using Mel Frequency Cepstral Coefficient (MFCC) and Dynamic Time Warping (DTW) Techniques," *Journal of Computing*, vol. 2, no. 3, pp. 138–143, Mar. 2010.

### 3.Short-Biography



**Huan Minh Vo** received the B.S. and M.S.E.E. degrees in Electronics and Communication Engineering from the Ho Chi Minh City University of Technology, Vietnam in 2005 and 2007. and Ph.D. degree in Electronics Engineering from Kookmin University, Seoul, Korea in 2013.

He is currently working as a lecturer at the Faculty of Electrical and Electronics Engineering, University of Technology and Education, Ho Chi Minh City, Vietnam. His current research interests include neuromorphic computation using emerging technology.

The 3<sup>rd</sup> International Workshop on Engineering Physics, IC-MEMS-Sensors and  
Their Applications (3<sup>rd</sup>IWEMA2022)  
*November-25&26,2022; Ho Chi Minh City, Vietnam*

*Host by Faculty of Physics- Engineering Physic, University of Science,  
Vietnam National University- HCMC)  
and Ono Lab, Tohoku University, Sendai, Japan*

**PARALLEL SESSION: Invited talk**  
**(Session 3, code: IN-12)**

**1. Invited speaker**

Title of talk: Nanoscale Memristor Crossbar Array – A Potential Candidate for Neuromorphic Computing.

Author (s): Truong Ngoc Son and Le Minh.

Institution (s): HCMC University of Technology and Education.

Country: Vietnam

Speaker: Truong Ngoc Son

Academic title: Associate Professor, Senior lecturer

E-mail: sontn@hcmute.edu.vn Handphone: +84931085929

**2. Abstract**

With the nonlinear charge-flux relationship and the capability of forming as crossbar arrays, the nanoscale memristor is a promising candidate for implementing neuromorphic computing systems. In this study, we present various architectures of memristor crossbar arrays for performing neuromorphic pattern recognition. When implementing the binary neuromorphic pattern recognition, the XNOR function needs to be performed between the input pattern and the memristor arrays. We introduce three architectures of memristor crossbar arrays, namely the complementary crossbar architecture, the twin crossbar architecture, and the single crossbar architecture, for binary neuromorphic pattern recognition. We also test the memristor crossbar architectures with a task of recognizing ten binary images. The simulation results prove that the memristor crossbar architectures

perform precisely the XNOR function and eligible for neuromorphic pattern recognition systems.

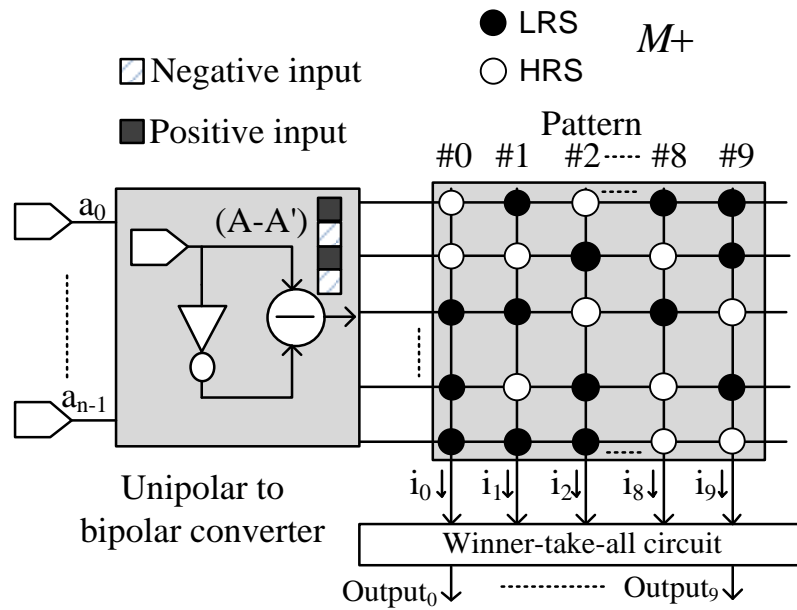

Fig.1. The single memristor crossbar array for neuromorphic pattern recognition.

\*Keywords: memristor arrays, XNOR function, neuromorphic computing, pattern recognition.

\*References:

- [1] L. Chua, "Memristor-The missing circuit element," *IEEE Transactions on Circuit Theory*, vol. 18, pp. 507-519, 1971.
- [2] D. B. Strukov, G. S. Snider, D. R. Stewart, and R. S. Williams, "The missing memristor found," *Nature*, vol. 453, pp. 80-83, 2008/05/01 2008.
- [3] C. Mead, "Neuromorphic electronic systems," *Proceedings of the IEEE*, vol. 78, pp. 1629-1636, 1990.
- [4] S. N. Truong, S.-J. Ham, and K.-S. Min, "Neuromorphic crossbar circuit with nanoscale filamentary-switching binary memristors for speech recognition," *Nanoscale Research Letters*, vol. 9, p. 629, 2014/11/23 2014.
- [5] S. N. Truong, S. Shin, S. Byeon, J. Song, and K. Min, "New Twin Crossbar Architecture of Binary Memristors for Low-Power Image Recognition With Discrete Cosine Transform," *IEEE Transactions on Nanotechnology*, vol. 14, pp. 1104-1111, 2015.
- [6] S. N. Truong, "Single Crossbar Array of Memristors With Bipolar Inputs for Neuromorphic Image Recognition," *IEEE Access*, vol. 8, pp. 69327-69332, 2020.

The 3<sup>rd</sup> International Workshop on Engineering Physics, IC-MEMS-Sensors and  
Their Applications (3<sup>rd</sup>IWEMA2022)  
*November-25&26,2022; Ho Chi Minh City, Vietnam*

*Host by Faculty of Physics- Engineering Physic, University of Science,  
Vietnam National University- HCMC)  
and Ono Lab, Tohoku University, Sendai, Japan*

**PARALLEL SESSION: Invited talk**  
**(Session 4, code: IN-13)**

**1.Invited speaker**

Title of talk: Some results of NEMO-VN2, simulation program used for emerging nanoelectronic devices

Author (s): Dinh Sy Hien

Institution (s): HCM University of Science

Country: Vietnam

Speaker: Dinh Sy Hien

Academic title: Professor

E-mail: dshien@hcmus.edu.vn

Handphone: 0767899448

**2.Abstract**

We have developed a simulation program, NEMO-VN2, used for simulating emerging nanoelectronic devices. These devices are including the resonant tunneling diode, the single electron transistor, the molecular field effect transistor, the carbon nanotube field effect transistor, spin field effect transistor, graphene field effect transistor. The non-equilibrium Green's function method is used to perform a comprehensive study of emerging nanoelectronic devices. The program has been written by using graphic user interface of Matlab. NEMO-VN2 uses Matlab to compute Landauer formula to get current-voltage characteristics of nanoelectronic devices. In this work, we provide a short overview of the emerging nanoscale devices, and their simulations. The simulation program uses not only for research of nanoelectronic devices, but also for training post-graduated students in HCM University of Science.

Keywords: resonant tunneling diode, single electron transistor, molecular field effect transistor, carbon nanotube field effect transistor, spin field effect transistor, graphene field effect transistor.

### **3. Short- Biography**

Full name: Dinh Sy Hien

Date of birth: 25-12-1952

Academic title: Professor, PhD

Research field: Nuclear Electronics and Nanoelectronics

Process of Education:

I have graduated Hanoi University, Major: Nuclear Physics in 1974

I have received PhD on Nuclear Physics in 1992

I have received academic title of Ass. Professor in physics in 1996.

I have received academic title of Professor in Physics in 2014.

Foreign Languages: Russian and English

E-mail: dshien@hcmus.edu.vn

Handphone: 0767899448

### **Activities**

From 1974 to 1979 I have worked as scientific worker at Dalat Nuclear research Institute, in Dalat, Vietnam.

From 1979 to 1984 I have worked as scientific collaborator at Joint Institute for Nuclear Research in Dubna, Soviet Union.

From 1984 to 2001 I have worked as scientific worker and senior scientific worker at Dalat Nuclear Research Institute, in Dalat, Vietnam.

From 2001 up to now I have worked as senior lecturer at HCM University of Science, in HCM city, Vietnam.

Number of publications: 60 (in field of nuclear electronics & nanoelectronics)

List of published textbooks and chapters of textbooks:

- 1) Dinh Sy Hien, Nanoelectronics: Devices and Technology, Publisher of HCM-VNU, 2005
- 2) Dinh Sy Hien, MEMS & NEMS: Materials, Design and Fabrication, Publisher of HCM-VNU, 2011.
- 3) Dinh Sy Hien, VLSI Technology, Publisher of HCM-VNU, 2010.
- 4) Dinh Sy Hien, Semiconductor Devices, Publisher of HCM-VNU, 2008.
- 5) Dinh Sy Hien, Sensors and Measurement Instruments, Publisher of HCM-VNU, 2010.
- 6) Dinh Sy Hien, Modeling of Carbon Nanotube Field Effect Transistors, Chapter 8, Carbon Nanotubes Applications on Electron Devices, edited by Jose Mauricio Marulanda, Publisher of Intech, 2011.

The 3<sup>rd</sup> International Workshop on Engineering Physics, IC-MEMS-Sensors and  
Their Applications (3<sup>rd</sup>IWEMA2022)  
November-25&26,2022; Ho Chi Minh City, Vietnam

*Host by Faculty of Physics- Engineering Physic, University of Science,  
Vietnam National University- HCMC)  
and Ono Lab, Tohoku University, Sendai, Japan*

**PARALLEL SESSION: Invited talk**  
**(Session 4, code: IN-14)**

**1. Invited speaker**

Title of talk: Counting CD4<sup>+</sup> T cells with microfluidic counter and functional nanoparticles

Author (s): Nguyen Hoang Nam<sup>1,2\*</sup>, Do Quang Loc<sup>1</sup>, Phi Thi Huong<sup>1</sup>, Luu Manh Quynh<sup>1</sup>,  
Pham Thi Thu Huong<sup>1</sup>, Nguyen Thi Van Anh<sup>1</sup>, Bui Thanh Tung<sup>3</sup>, Chu Duc  
Trinh<sup>3</sup>, Nguyen Hoang Luong<sup>1,2</sup>

Institution (s):

<sup>1</sup>VNU University of Science, Vietnam National University, Hanoi, Vietnam

<sup>2</sup>Vietnam Japan University, Vietnam National University, Hanoi, Vietnam

<sup>3</sup>VNU University of Engineer and Technology, Vietnam National University, Hanoi,  
Vietnam

Country: Vietnam

Speaker: Nguyen Hoang Nam

Academic title: Associate Professor

E-mail: [namnh@hus.edu.vn](mailto:namnh@hus.edu.vn) Handphone: +84-913-020268

**2. Abstract**

A device to count CD4<sup>+</sup> T-cells was developed to be used both in detection and treatment process of immunodeficiency diseases, such as HIV, aiming to used commonly and cost-less due to its compactness. Carboxyl groups functionalized magnetic nanoparticles with size of 100-200 nm were conjugated to anti-CD4 antibodies. The anti-CD4 antibodies ensure specific interaction with the CD4 receptor on CD4<sup>+</sup> T cells. These antibody conjugated nanoparticles, then, were incubated with 50  $\mu$ L of blood sample. After the incubation, the CD4<sup>+</sup> T cells in blood sample are binded with the magnetic nanoparticles

and were captured by a magnet before being pumped through a microfluidic system. A three-electrode differential capacitance counter was designed in the microfluidic system to recognize the CD4<sup>+</sup> T cells go through the electrodes. Total number of the CD4<sup>+</sup> T cells were counted by counting the electrical peaks generated when the cells passed through the electrodes and analyzed using in-built software. The results of the cell counting then were compared with the gold standard test of the cell counting using the FACS Canto system. It was shown that the developed device gives stable results over a wide range of CD4<sup>+</sup> T cell concentrations tested (1000–200 CD4<sup>+</sup> T cells/μL blood) and correlates well with the results on the gold standard FACS system.

\*Keywords: magnetic nanoparticles, functional nanoparticles, microfluidic system, CD4<sup>+</sup> T cell counter, anti-CD4 antibody,

### 3.Short- Biography

**Full name:** Nguyen Hoang Nam, Ph.D.

**Academic title:** Associate Professor

**Institute:** VNU University of Science, Vietnam National University, Hanoi, Vietnam



#### Contacts:

Email: namnh@hus.edu.vn

Handphone: (+84)-913-020286

#### 1. Research Areas:

- Nanomaterials for life-science applications
- Magnetic nanoparticles
- Biosensor and microfluidic systems

#### 2. Faculty/Department/Laboratory

- Nano and Energy Center
- Faculty of Physics
- Nanotechnology Master Program

#### 3. Research Activities

1. Development of portable device for counting CD4<sup>+</sup> T cells using nanoparticles and microfluidic system
2. Development of wound healing techniques using stem-cell spray gun and bio-nanomembranes
3. Application of MUSE cells in tubular tissue creation using scaffold-free based 3D bio-printing technology

#### 4. Research Achievements and Awards:

##### *Books*

1. Nguyen Hoang Nam, Nguyen Hoang Luong, Chapter 7 - Nanoparticles: Synthesis and Applications. Materials for biomedical engineering: Inorganic Micro and Nanostructures, Elsevier 2019, ISBN 978-0-08-102814-8, pp 211-240
2. Nguyen Hoang Nam, Chapter 3 – Multifunctional silver nanoparticles: Synthesis and applications. Silver micro-nanoparticles: Properties, Synthesis, Characterization, and

## 5. ISI Selected Publications

[1]. Nguyen Hoang Luong, Truong Thanh Trung, Tran Thi Hong, Nguyen Hoang Nam, Manh-Huong Phan, Péter Jenei, János L Lábár, Jenő Gubicza, Relating the magnetic coercivity to the  $L1_0$  ordered  $FePd$  phase in annealed  $Fe_xPd_{100-x}$  nanoparticles, *Applied Physics A* 128 (10) (2022), 1-11.

[2]. Ngoc Duc Vo, Anh Thi Van Nguyen, Hoi Le Thi, Nam Hoang Nguyen, Huong Thi Thu Pham, A Simple Approach for Counting  $CD4^+$  T Cells Based on a Combination of Magnetic Activated Cell Sorting and Automated Cell Counting Methods, *Applied Sciences* 11(21) (2021), 10.3390/app11219786

[3]. An T.Pham, Dzung T.Tran, Linh H.Vu, Nang T.T.Chu, Nguyen DuyThien, Nguyen H.Nam, Nguyen ThanhBinh, Luu T.Tai, Nguyen T.M.Hong, Nguyen ThanhLong, Duc H.Tran, Effects of  $TiO_2$  nanoparticle addition on the flux pinning properties of the  $Bi_{1.6}Pb_{0.4}Sr_2Ca_2Cu_3O_{10+\delta}$  ceramics, *Ceramics International* 48(14) (2022), 20996-21004

The 3<sup>rd</sup> International Workshop on Engineering Physics, IC-MEMS-Sensors and  
Their Applications (3<sup>rd</sup>IWEMA2022)  
*November-25&26,2022; Ho Chi Minh City, Vietnam*

*Host by Faculty of Physics- Engineering Physic, University of Science,  
Vietnam National University- HCMC)  
and Ono Lab, Tohoku University, Sendai, Japan*

**PARALLEL SESSION: Invited talk**  
**(Session 5, code: IN-15)**

**1. Invited speaker**

Title of talk: Natural polymer-based hydrogel bioinks for biomedical applications

Author (s): Thi-Hiep Nguyen

Institution (s): International University, Vietnam National University HCM City

Country: Vietnam

Speaker: Thi-Hiep Nguyen

Academic title: Associate Professor, Senior lecturer

E-mail: [nthiep@hcmiu.edu.vn](mailto:nthiep@hcmiu.edu.vn) Handphone: +84-983-888-700

**2. Abstract**

Three-dimensional (3D) bioprinting is a novel technique for creating cell-laden 3D scaffolds by depositing cells and biomaterials in defined shapes and patterns to mimic complicated tissue structures. Bioprinting relies on bioinks, which are hydrogel solutions that serve as both cell carriers and structural components. Bioinks must be highly printable while also providing a stable and biocompatible microenvironment. Among many biomaterials used as bioinks, natural polymer-based hydrogels have gotten increased attention because of their intrinsic physicochemical and biological properties, as well as their multiple medicinal uses (e.g., wound healing, drug delivery, and tissue engineering). This talk describes some advances in using biopolymer hydrogels as bioinks for biomedical applications as well as opportunities and challenges associated with the 3D bioprinting fabrication of hydrogels.

\*Keywords: 3D bioprinting, tissue engineering, hydrogel, bioinks, biomedical engineering

\*References:

### 3. Short- Biography

**Full name:** Thi-Hiep NGUYEN, Ph.D.

**Academic title:** Associate Professor

**Institute:** School of Biomedical Engineering, International University, Vietnam National University Ho Chi Minh City, Vietnam



#### 1. Research Areas:

- Biomaterials for skin and Bone regeneration.
- Injectable hydrogel systems for skin and bone regeneration.
- Control/release drug/growth factors.
- Electrospinning system, nano/micro-particles.
- Titanium modifications: targeting soft tissue interaction
- Stem cell differentiation: using human bone marrow stem cells (hBMSC) model, mesenchymal stem cells derived.
- Extraction and Isolation of Biomaterials from natural sources.
- Biomaterials for Cosmetics applications.
- Surface modification of medical filtration such as artificial kidney.
- Control/release of anticancer drugs.

#### Contacts:

Email:

nthiep@hcmiu.edu.vn

Handphone: (+84)-

983-888-700

#### 2. Faculty/Department/Laboratory

- School of Biomedical Engineering
- Tissue Engineering and Regenerative Medicine Laboratory

#### 3. Research Activities

Nguyen Thi Hiep got her Ph.D. from SoonChunHyang University in South Korea in 2012. Prof. Hiep returned to Vietnam shortly after graduation to establish the Tissue Engineering and Regenerative Medicine lab at School of Biomedical Engineering- International University - Vietnam National University HCM and to pursue her research interests in biomaterials fabrication. Prof. Hiep has published over 90 articles that have been indexed in the ISI and Scopus systems, 15 domestic papers, 3 book chapters, 80 papers in international conferences, and 3 granted patents. Her interdisciplinary research focuses on the design and preparation of biomaterials for biological, medical, and pharmaceutical applications, bringing together the fields of materials science, pharmaceutical science, cell therapy, basic and clinical medicine.

Currently, Prof. Hiep is the Dean of the School of Biomedical Engineering at International University, VNU HCMC. Prof. Hiep has participated in over 20 research grants at different levels both domestically and internationally. Especially, she received many Awards and Prizes from different agents such as the National Fellowship Award from L'Oreal UNESCO for Women Science (2016); the winner of the ASEAN-US Science Prize for Women Science (2017); the International Rising Talent of the L'Oreal UNESCO for Women Science (2018); the first prize in Innovation Awards Ho Chi Minh City and was named among the Top 100 most outstanding scientists in Asia released by Singapore's Asian Scientist magazine in 2019.

She has also been invited to several public speaking engagements to promote women in science, such as STEM conferences, which highlight the accomplishments of women in STEM and inspire, educate, and connect women in the science, technology, engineering, and math communities. Besides, she has been nominated for various events to encourage young people to do research, such as the Chat with Scientists program organized by Oxford University in Vietnam and GYSS2017 in Singapore.

#### **4. Research Achievements and Awards:**

##### *Books*

Vo Van Toi, Le Quoc Trung, Ngo Thanh Hoan and **Nguyen Thi Hiep**. Translational Health Science Technology for Developing Countries. BME7 in Vietnam, IFMBE Proceeding 2018.

Mohseni, Mina, Nathan J. Castro, Hoang Phuc Dang, Tan Dat Nguyen, Hieu Minh Ho, Minh Phuong Nam Tran, **Thi Hiep Nguyen**, and Phong A. Tran. "Adipose tissue regeneration: Scaffold-Biomaterial strategies and translational perspectives." In Biomaterials in Translational Medicine, pp. 291-330. Academic Press, 2019.

Vo Van Toi, **Nguyen Thi Hiep**, Vong Binh Long, Ha Thi Thanh Huong: Proceedings of BME8, 2020, Vietnam: Healthcare technology for smart city in low- and middle-income countries. Springer publishing house: Springer (May 2021).

Vo Van Toi, **Nguyen Thi Hiep**, Ha Thi Thanh Huong, Vong Binh Long, Nguyen Ngoc Quang, Nguyen Hoai Thuong: "Ky thuat Y sinh Dai Cuong". Vietnam National University VNUHCM Press (2022).

##### *Research Awards*

Certificate of The Executive Board of the International University Party Committee awarded the Certificate of Merit for "Successfully completing the task in 2021"

Certificate of The Executive Board of the International University Party Committee awarded the Certificate of Merit "for outstanding achievements in studying and following Ho Chi Minh's thought and morality in the academic year 2021 - 2022"

Certificate of Merit from the Party Committee of VNU-HCM for outstanding achievements in studying and following Ho Chi Minh's ideology, morality and style in the 2016-2021 period.

Certificate of Merit from the the Party Committee of VNU-HCM for outstanding achievements in the "Outstanding People's Movement" in the 2015-2020 period.

Excellent researcher from 2018-2019, International University, Vietnam National University.

Certificate of VNU-HCM for the achievement of "Excellent Scientific Publication" and "Annual Science and Technology VNU-HCM" Awards. in 2019 – 2020

Certificate of Merit from the Minister of Education and Training For outstanding achievements in the patriotic emulation movement of the Education sector in the 2016-2020 period

Certificate of Merit from the President of VNU-HCM for

successfully completing the task from the academic year 2018 - 2019 to the academic year 2019 - 2020.

The project "Smart glue in wound healing treatment" was selected, edited, published and released for the Vietnam Innovation Gold Book 2020.

Excellent researcher from 2016-2018, International University, Vietnam National University.

Outstanding researcher for excellent great contribution in success of Vietnam National University, Vietnam National University.

The first prize in Innovation Awards Ho Chi Minh City

Top 100 most outstanding scientists in Asia released by Singapore's Asian Scientist magazine

Outstanding performance from 09/2015 to 06/2018, Vietnam National University, June 2018, Ho Chi Minh, Vietnam.

Learning and Working following Ho Chi Minh Thoughts Award, May 2018, Ho Chi Minh, Vietnam.

The L'Oreal UNESCO for Women in Science, International Rising Talents 2018, March 2018, Paris, France.

The outstanding lecturer of the year 2017, International University, Vietnam National University.

The winner of ASEAN-US Prize Science for Women in 2017, ASEAN.

Excellent researcher for outstanding applicable projects Prize, VNU-HCMC, Vietnam.

Scientist has ISI publication Prize, VNU-HCMC, Vietnam.

Scientist has ISI publication Prize, International University, Vietnam.

Scientist has ISI publication, VNU-HCMC, Vietnam.

The L'Oreal UNESCO for Women in Science, National Fellowship Program, Vietnam.

## **5. ISI Selected Publications (2016-now): 77 Publications**

### **6. Invited talks**

#### **The 2017 Women in STEM Conference: Gender Roles in Education, Leadership and Culture**

*Topic: Turning Challenges into Your Launch Pad for Success*

#### **The First 2016 Women in STEM Conference: Women in Entrepreneurship and Innovation**

*Topic: Leadership & Women in Technology Developing and Leading in STEM: critical Competencies to Advance your Career"*

#### **The annual scientists meeting at SHTP**

*Topic: Application of Silk-Collagen-Chitosan in Tissue Engineering and Regenerative Medicine*

#### **The workshop L'Oreal for Women in Science**

*Topic: How to apply for the L'OREAL For Women in Science National Fellowship 2017*

#### **Chat with Scientists**

*Topic: What is Tissue Engineering and Regenerative Medicine*

The 3<sup>rd</sup> International Workshop on Engineering Physics, IC-MEMS-Sensors and  
Their Applications (3<sup>rd</sup>IWEMA2022)  
*November-25&26,2022; Ho Chi Minh City, Vietnam*

*Host by Faculty of Physics- Engineering Physic, University of Science,  
Vietnam National University- HCMC)  
and Ono Lab, Tohoku University, Sendai, Japan*

**PARALLEL SESSION: Invited talk**  
**(Session 5, code: IN-16)**

**1. Invited speaker**

Title of talk: SiPM for proton beam monitors at J-PARC

Author (s): Cao Van Son

Institution (s): The Institute For Interdisciplinary Research in Science and Education  
(IFIRSE), Quy Nhon

Country: Vietnam

Speaker: Son Cao

Academic title: Ph.D.

E-mail: cvson@ifirse.icise.vn

Handphone:

**2. Abstract**

This talk will focus on two types of proton beam monitors that were recently developed at the J-PARC extraction neutrino beamline. The first is to monitor the beam profiles non-destructively, and the second is to monitor and allocate the beam loss using time-of-light measurements. Both use the single-photon-resolving nanosecond-response photosensor SiPM to detect fast (few nanoseconds) and faint (few 10s to 100s photoelectron) light. SiPM is used in conjunction with multimode optical fiber as a light guide and Cherenkov light-induced materials. The concept and practical application in a highly radioactive environment will be described in detail.

\*Keywords : SiPM, beam loss monitor, beam profile monitor, non-destructive

**\*References:**

- [1]. S.V. Cao, M.L. Friend, *Investigation of an Optical-Fiber Based Beam Loss Monitor at J-PARC Extraction Neutrino Beamline*, IBIC2020, Santos, Brazil
- [2]. M.L. Friend, S.V. Cao, et al, *First Beam Profile Measurement by Beam Induced Fluorescence at the J-PARC Neutrino Extraction Beamline*, IBIC2022, Santos, Brazil

**3.Short- Biography**

**Name: Cao Van Son, PhD.,**

Position title: Researcher,

Leader of Neutrino Group, IFIRSE

**\*Education and Information:**

-2008: Bachelor degree at University of Science, VNU Ha Noi, Vietnam

-2014: PhD degree at The University of Texas at Austin, US



For more than a decade, I have been chasing the unknown in neutrino physics. And I am very excited about the possibility that neutrinos were responsible for the birth of our Universe, as hinted by our recent work with T2K data, which will be published in Nature in 2020. I spent 5 years in the United States and 6 years in Japan conducting academic research to gain transdisciplinary knowledge in particle and nuclear physics, material science, mechanics, electronics, and data mining. My low-light signal detection technical knowledge is being used to improve the non-destructive MW-class beam profile monitor and optical-fiber based beam loss monitor. The technique has a wide range of civil applications, and I am excited to investigate its potential through an interdisciplinary approach.

**\* Current and Past Positions**

- 01/09/2012-31/05/2014: Graduate Research Assistant at The University of Texas at Austin, US

- 01/07/2014-15/11/2014: Postdoctoral research associate at Okayama University, Japan.

- 17/11/2014-17/11/2016: JSPS fellow at Kyoto University, Japan

- 17/11/2016-30/11/2016: Postdoctoral researcher at Kyoto University, Japan

- 01/12/2016-31/03/2021: KEK postdoctoral researcher, Japan

- 01/04/2021-current: *Leader of Neutrino Group, IFIRSE, VN*

**\* Awards and Honors**

- Vietnam Education Foundation fellowship, 2009-2014

- Japan Society for the Promotion of Science, 2015-2017

**\* Publications: Related publications:**

1. “First beam profile measurements by beam induced fluorescence at the J-PARC Neutrino Extraction Beamline”, S. Cao *et al.*, DOI: 10.18429/JACoW-IBIC2020-WEPP34
2. “Investigation of an Optical-Fiber Based Beam Loss Monitor at the J-PARC Extraction Neutrino Beamline”, S. Cao *et al.*, DOI: 10.18429/JACoW-IBIC2020-WEPP06
3. “Multi-pixel Photon Counter for operating the tabletop cosmic-ray detector under loosely controlled conditions”, S. Cao *et al.*, arXiv:2106.08603

Other Best Recent publications

4. “Physics potentials with a combined sensitivity of T2K-II, NOvA extension and JUNO”, S. Cao *et al.*, Phys. Rev. D 103, 112010 (2021)
5. “Constraint on the matter-antimatter symmetry-violating phase in neutrino oscillations”, S. Cao *et al.* [T2K Collaboration], Nature 580 (2020) 7803, 339-344.
6. “T2K measurements of muon neutrino and antineutrino disappearance using 3.13x10<sup>21</sup> protons on target”, S. Cao *et al.* [T2K collaboration], Phys.Rev.D 103 (2021) 1, L011101
7. “Search for proton decay via and with an enlarged fiducial volume in Super-Kamiokande I-IV”, S. Cao *et al.* [Super-Kamiokande collaboration], Phys.Rev.D 102 (2020) 11, 112011

$$p \rightarrow e+\pi^0 \quad p \rightarrow \mu+\pi^0$$

The 3<sup>rd</sup> International Workshop on Engineering Physics, IC-MEMS-Sensors and  
Their Applications (3<sup>rd</sup>IWEMA2022)  
*November-25&26,2022; Ho Chi Minh City, Vietnam*

*Host by Faculty of Physics- Engineering Physic, University of Science,  
Vietnam National University- HCMC)  
and Ono Lab, Tohoku University, Sendai, Japan*

**PARALLEL SESSION: Invited talk**  
**(Session 5, code: IN-17)**

**1.Invited speaker**

Title of talk: **Low cost techniques for fabrication of point of care testing microfluidics in low-resource settings**

Author (s): Khon Huynh, Ph.D.

Institution (s): International University, Vietnam National University in Ho Chi Minh city

Country: Vietnam

Speaker: Khon Huynh, Ph.D.

Academic title: Lecturer

E-mail: hckhon@hcmiu.edu.vn

Handphone: 0902 884 865

**2.Abstract**

Microfluidics are expected to revolutionize the healthcare industry especially in developing countries since it would bring portable, easy-to-use, self-contained diagnostic devices to places with limited access to healthcare. To date, however, microfluidics has not yet been able to live up to these expectations. One non-negligible factor can be attributed to inaccessible prototyping methods for researchers in low-resource settings who are unable to afford expensive equipment and/or obtain critical reagents and, therefore, unable to engage and contribute to microfluidics research. Our research group have been developed low-cost techniques for microfluidic fabrication that require minimal capital, running costs, or minimal fabrication process. We then applied our techniques to design microfluidic chips

and devices for point-of-care nucleic acid amplification testing applications. In this talk, we will present our experience, recent progress, and opportunities

\*Keywords: low cost microfluidic, point of care testing, nucleic acid amplification

\*References:

[1]. Thien Hoang, Bao-Han Ly, Thanh-Xuan Le, Thanh-Thao Huynh, Hoang-Tuan Nguyen, Toi Van Vo, Thi Thu Hien Pham, Khon Huynh. MINIMAL MICROFABRICATION REQUIRED DIGITAL MICROFLUIDIC SYSTEM TOWARD POINT-OF-CARE NUCLEIC ACID AMPLIFICATION TEST APPLICATION FOR DEVELOPING COUNTRIES. *Microsystem Technology* 26, 1863–1873 (2020).

[2]. Hoang-Tuan Nguyen, Ha Thach, Emmanuel Roy, Khon Huynh\*, Cecile Mong-Tu Perraul\*, LOW-COST, ACCESSIBLE FABRICATION METHODS FOR MICROFLUIDICS RESEARCH IN LOW-RESOURCE SETTINGS. *Micromachines* 2018, 9, 461

### 3.Short- Biography

**Full name:** Khon HUYNH, Ph.D.

**Academic title:** Lecturer

**Institute:** School of Biomedical Engineering, International University – Vietnam National University in Ho Chi Minh City, Vietnam



**Contacts:**

Email:

[hckhon@hcmiu.edu.vn](mailto:hckhon@hcmiu.edu.vn)

Handphone: (+84)

902884865

#### 1.Research Areas:

- Point-of-care diagnostics
- Lab-on-a-chip, microfluidics, lateral flow assay
- Vascular biology

#### 2. Faculty/Department/Laboratory

- School of Biomedical Engineering
- Lab on a chip and biosensors

#### 3. Research Activities

**University Lecturer**, School of Biomedical Engineering, International University – Vietnam National University in Ho Chi Minh City, Vietnam, 2014 – present

**Friend**, Vietnam Young Academy, 2017-present

**Researcher (Sabbatical Leave)**, Dynamics of Viral Structures group, Heinrich Pette Institute – Leibniz Institute of Experimentelle Virologie, 2019-2020

**Member**, International Society of Hemostasis and Thrombosis (ISTH), 2017-2018

**Organizer**, Vietnam-UK Newton Workshop “Microfluidics, Nanomaterials, and Point-of-Care in Healthcare for developing countries”, 2018

**Local organization committee, Session Chair** (Tissue Engineering & Regenerative Medicine) - The 6th and 7th International Conference on the Development of Biomedical Engineering in Vietnam, 2016 & 2018

**Researcher and Postdoctoral Researcher**, Vascular Biology

Group IHTM, University Hospital of Dusseldorf, Germany, 2009-2014

**Researcher**, Biotherapeutics Group - Biotechnology center of Ho Chi Minh city, Vietnam, 2009

**Researcher**, Molecular Biology Laboratory, Ajou University, Korea, 2006-2009

#### **4. Research Achievements and Awards:**

*Research Awards*

**ISTH Fellowship Award 2018**, International Society of Thrombosis and Hemostasis (<https://www.isth.org/news/392202/Meet-the-Newest-Reach-the-World-Fellows.htm>), 2018

**Excellent Scientific Publication Award**, International University, Vietnam, 2017

**Abstract achievement award and Travel grant award**, ISTH Meeting in Kyoto, Toronto and Berlin, 2011, 2015 & 2017

**Scholarship for outstanding academic achievement**, University of Agriculture and Forestry, Ho Chi Minh, Vietnam, 2005 & 2006

#### **5. Selected Publications (2014-now)**

Le, H., Mai-Thi, H.-N., Le, X., Tran, N. Q., Tu Tran, C., & Huynh, K. (2022). The concentration-independence cellular effects of fibronectin adsorbed on material surfaces with different hydrophobicities. *Vietnam Journal of Biotechnology*, 20(3), 435–444. <https://doi.org/10.15625/1811-4989/16585>

Nguyen, N.H., Dang, L.H., Doan, P. et al. Polyacrylic-conjugated polyamidoamine G4.0 dendrimer as a potential nanocarrier for effective delivery of cisplatin. *Bull Mater Sci* 44, 87 (2021). <https://doi.org/10.1007/s12034-021-02382-w>

Le, Phong, Mai-Thi, Hoang-Nghi, Stoldt, Volker R., Tran, Ngoc Quyen and Huynh, Khon. "Morphological dependent effect of cell-free formed supramolecular fibronectin on cellular activities" *Biological Chemistry*, vol. 402, no. 2, 2021, pp. 155-165. <https://doi.org/10.1515/hsz-2019-0402>

Thien Hoang, Bao-Han Ly, Thanh-Xuan Le, Thanh-Thao Huynh, Hoang-Tuan Nguyen, Toi Van Vo, Thi Thu Hien Pham, Khon Huynh. MINIMAL MICROFABRICATION REQUIRED DIGITAL MICROFLUIDIC SYSTEM TOWARD POINT-OF-CARE NUCLEIC ACID AMPLIFICATION TEST APPLICATION FOR DEVELOPING COUNTRIES. *Microsystem Technology* 26, 1863–1873 (2020).

Hoang-Tuan Nguyen, Ha Thach, Emmanuel Roy, Khon Huynh\*, Cecile Mong-Tu Perraul\*, LOW-COST, ACCESSIBLE FABRICATION METHODS FOR MICROFLUIDICS RESEARCH IN LOW-RESOURCE SETTINGS. *Micromachines* 2018, 9, 461

Phung Ngan Le, Chan Khon Huynh, Ngoc Quyen Tran. ADVANCES IN THERMOSENSITIVE POLYMER-GRAFTED PLATFORMS FOR BIOMEDICAL APPLICATIONS. Material Science and Engineering C, 2018

Huong Nguyen, Khon Huynh\* and Volker R Stoldt. SHEAR-DEPENDENT FIBRILLOGENESIS OF FIBRONECTIN: IMPACT OF PLATELET INTEGRINS AND ACTIN CYTOSKELETON. Biochemical and Biophysical Research Communications, 2018

Alexander Assmann, Marc Struß, Franziska Schiffer, Friederike, Heidelberg, Hiroshi Munakata, Elena V. Timchenko, Pavel E. Timchenko, Tim Kaufmann, Khon Huynh, Yukiharu Sugimura, Quentin Leidl, Antonio Pinto, Volker R. Stoldt, Artur Lichtenberg, Payam Akhyari; IMPROVEMENT OF THE IN VIVO CELLULAR REPOPULATION OF DECELLULARIZED CARDIOVASCULAR TISSUES BY A DETERGENT-FREE, NON-PROTEOLYTIC, ACTIN DISASSEMBLING REGIMEN. Journal of Tissue Engineering and Regenerative Medicine 2017. IF: 4.71

Tra Thanh Nhi, Huynh Chan Khon, Nguyen Thi Thu Hoai, Bui Chi Bao,

Tran Ngoc Quyen, Vo Van Toi, Nguyen Thi Hiep, FABRICATION OF ELECTROSPUN POLYCAPROLACTONE COATED WITH CHITOSAN-SILVER NANOPARTICLES MEMBRANES FOR WOUND DRESSING APPLICATIONS, J Mater Sci: Mater Med (2016) 27:156, IF 2.272

K. Huynh, M. Gyenes, C. P. Hollenberg, TH. Nguyen, TV Vo, V. R. Stoldt, FIBRONECTIN UNFOLDED BY ADHERENT BUT NOT SUSPENDED PLATELETS: AN IN VITRO EXPLANATION FOR ITS DUAL ROLE IN HAEMOSTASIS, Thrombosis Research 136 (2015) 803–812

# 3.

# ORAL

# SESSION

Venue: University of Science, VNUHCM  
*227 Nguyen Van Cu Str., District 5, Ho Chi Minh city,  
Vietnam*

The 3<sup>rd</sup> International Workshop on Engineering Physics, IC-MEMS-Sensors and  
Their Applications (3<sup>rd</sup>IWEMA2022)  
November-25&26,2022; Ho Chi Minh City, Vietnam

*Host by Faculty of Physics- Engineering Physic, University of Science ,  
Vietnam National University- HCMC)  
and Ono Lab, Tohoku University, Sendai, Japan*

**ORAL SESSION (Session 1, Code: OR-01)**

**1.About speaker**

Title of talk: Green synthesis of reduced-graphene oxide quantum dots and application for colorimetric biosensor

Author (s): Le Duong Anh Duy and Kim Jeayong.

Institution (s): GES, SHTP, Vietnam

Country: Vietnam

Speaker: Le Duong Anh Duy

Academic title: PhD., Researcher

E-mail: anhduyvldt@gmail.com

Handphone:.0965582705

**2. Abstract**

We report a one-pot synthesis method to produce reduced-graphene oxide quantum dots (rGOQDs) in perfluorotributylamine (PFTBA) solution by avoiding the use of toxic materials and preventing the generation of undesirable functional groups (epoxy, carbonyl, and carboxyl). The PFTBA solution, consisting of three butyl fluoride groups connected to an amine center, effectively cracked down rGO precursors at  $\sim 160$  °C, and produced high purity of rGOQDs. Under UV irradiation, the location of the emission peak of the photoluminescence (PL) shifted from 489.3 nm to 460.8 nm as the solution temperature increased from 160 °C to 190 °C due to the enhancement of the bandgap. The produced sample exhibited a long-term photostability without the decay in intensity over 30 days, which can be used for an optical device. Depending on the oxidation state, PL spectra from the rGOQDs-solution mixed with glucose oxidase (GOx) changed the color from blue to

green with high sensitivity (3.869 deg/mM) in the glucose concentration of 0–2 millimole, demonstrating that rGOQDs can be applied for colorimetric biosensors using a portable smartphone.

\*Keywords: Graphene quantum dots, rGOQD, Green material, Glucose, Colorimetry

\*References:

- [1] P. Shemella, Y. Zhang, M. Mailman, P. M. Ajayan, S. K. Nayak, Energy gaps in zero dimensional graphene nanoribbons, *Appl. Phys. Lett.* 91 (2007) 042101.
- [2] S. Dey, A. Govindaraj, K. Biswas, C. N. R. Rao, Luminescence properties of boron and nitrogen-doped graphene quantum dots prepared from arc-discharge-generated doped graphene samples, *Chem. Phys. Lett.* 595 (2014) 203-208.
- [3] O. Hosu, M. Lettieri, N. Papara, A. Ravalli, R. Sandulescu, C. Cristea, G. Marrazza, Colorimetric multienzymatic smart sensors for hydrogen peroxide, glucose and catechol screening analysis, *Talanta* 204 (2019) 525.
- [4] L. Lin, X Song, Y Chen, M Rong, T Zhao, Y Wang, X Chen, Intrinsic peroxidase-like catalytic activity of nitrogen-doped graphene quantum dots and their application in the colorimetric detection of H<sub>2</sub>O<sub>2</sub> and glucose, *Analytica chimica acta*, 869 (2015) 89-95.

The 3<sup>rd</sup> International Workshop on Engineering Physics, IC-MEMS-Sensors and  
Their Applications (3<sup>rd</sup>IWEMA2022)  
*November-25&26,2022; Ho Chi Minh City, Vietnam*

*Host by Faculty of Physics- Engineering Physic, University of Science ,  
Vietnam National University- HCMC)  
and Ono Lab, Tohoku University, Sendai, Japan*

**ORAL SESSION (Session 1, Code: OR-02)**

**1.About speaker**

Title of talk: A Micromirror Driven by Electromagnetic Force for Fourier Transform Infrared Spectroscopy

Author (s): Chuan-Hui Ou, Nguyen Van Toan and Takahito Ono

Institution (s): Tohoku University

Country: Japan

Speaker: Ou Chuan Hui

Academic title: Doctoral student (D3)

E-mail: ou.chuan.hui.p5@dc.tohoku.ac.jp      Handphone: +81-070-4098-2089

**2. Abstract**

An electromagnetically driven 3-DOF micromirror with a large stroke is presented. The stroke reaches the highest level of electromagnetic micromirrors with an accurate tilting angle control mechanism, which allows spectrometers to achieve higher resolution. This research employs a novel actuation structure made of a unique material, metallic glass. It is the first attempt to integrate two functional elements, electromagnetic actuation element and mechanical supporting structure, into a single-layer spring made of metallic glass.

Some electromagnetic micromirrors have been reported [1-2]. However, most electromagnetic micromirrors have limited strokes and encounter the difficulty of precisely controlling the tilting angle. The micromirror is actuated by Lorentz force, as shown in Figure 1(a). There are four separated metallic glass springs. As current is applied to the springs in a perpendicular magnetic field, Lorentz force is generated. By controlling the current flowing in each spring, the angles of the micromirror can be controlled in two

directions. Figure 1(b) shows the cross-section of the micromirror. Figure 2 shows the measurement results.

\*Keywords: micromirror; electromagnetic; metallic glass; micro-interferometer; large stroke

\*References:

(1) Y. Xue and S. He, "A translation micromirror with large quasi-static displacement and high surface quality," *J Micromech Microeng*, vol. 27, no. 1, p. 015009, Oct. 2016.

(2) Y. Hongbin, Z. Guangya, C. F. Siong, L. Feiwen, W. Shouhua, and Z. Mingsheng, "An electromagnetically driven lamellar grating based Fourier transform microspectrometer," *J Micromech Microeng*, vol. 18, no. 5, p. 055016, Apr. 2008.

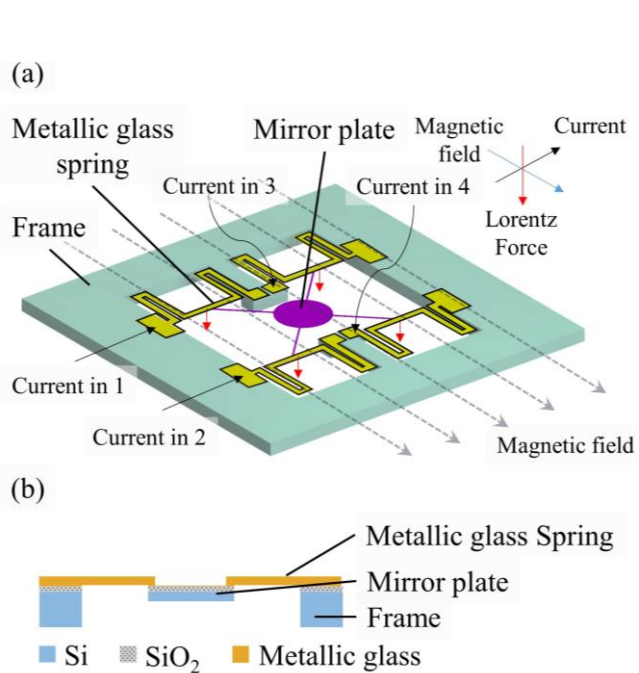

Figure 1: Schematic of the micromirror (a) and the cross section (b).

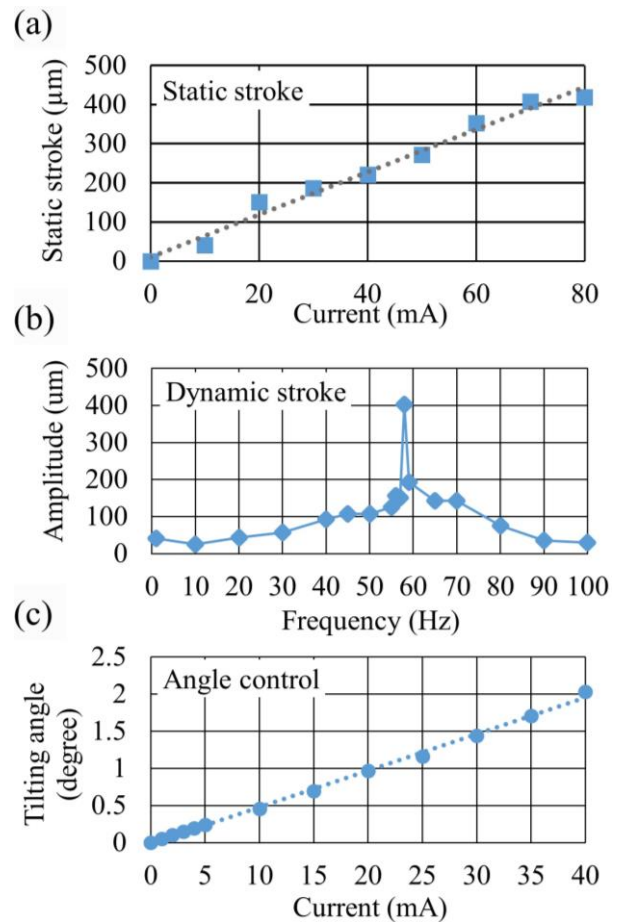

Figure 2: Experiment results of static stroke (a), dynamic stroke (b) and angle control (c).

The 3<sup>rd</sup> International Workshop on Engineering Physics, IC-MEMS-Sensors and  
Their Applications (3<sup>rd</sup>IWEMA2022)

*November-25&26,2022; Ho Chi Minh City, Vietnam*

*Host by University of Science (Vietnam National University- HCMC)  
and Tohoku University (Japan)*

**ORAL SESSION (Session 1, Code: OR-03)**

**1.About speaker**

Title of talk: A design TCADAS tool for semiconductor devices and case study of 65 nm conventional Floating-gate MOS transistor

Author (s): Dang Cong Thinh, Ton That Bao Phuc and Hoang Trang

Institution (s): Department of Electronics Engineering, Ho Chi Minh City University of Technology (HCMUT), Vietnam National University

Country: Vietnam

Speaker: Ton That Bao Phuc

Academic title: Ph.D student

E-mail: ttbphuc.sdh212@hcmut.edu.vn

Handphone: +84 983546415

**2. Abstract**

An automatic programming tool has become an essential component in virtual fabrication in recent years. This paper aims to propose a methodology of virtual fabrication for semiconductor devices and design a tool called Technology Computer-Aided Design Automatic Simulation (TCADAS) which can perform a completely virtual fabrication, device simulation, process variation, and output extraction. Especially, the TCADAS tool eliminates drudgery when studying semiconductor devices such as complexity in setting inputs, substantial manual work, and long run time of simulations. This work investigates the completed flow for a 65 nm conventional Floating-gate MOS transistor as a case study, which is widely considered a vital determinant of the non-volatile memory field. A detailed automatic process from the entry to a completed three-dimension structure, device characterization, extract important output parameters such as memory window, ION /IOFF,

Gate Coupling Ratio (GCR), and speed operations are presented. The TCADAS tool was designed by Python language and the utilities of TCAD Silvaco tools including Athena, Atlas, and DevEdit3D.

\*Keywords: TCAD Silvaco tool, Semiconductor device, Floating-gate MOS transistor, Device characterization.

\*References:

W. Hu, Z. Sheng, X. Hou, H. Chen, Z. Zhang, D. W. Zhang, and P. Zhou, "Ambipolar 2d semiconductors and emerging device applications," *Small Methods*, vol. 5, no. 1, p. 2000837, 2021.

S. Preethi, M. Venkatesh, M. Karthigai Pandian, and G. Lakshmi Priya, "Analytical modeling and simulation of gate-all-around junctionless mosfet for biosensing applications," *Silicon*, vol. 13, no. 10, pp. 3755–3764, 2021.

S.Chander, R.Chaudhary, and S.K.Sinha, "Tcad analysis of tunnel field effect transistor using ge material for low power application," *Materials Today: Proceedings*, vol. 50, pp. 2398–2403, 2022.

A. Hamzah, N. E. Alias, and R. Ismail, "Low-voltage high-speed programming gate-all-around floating gate memory cell with tunnel barrier engineering," *Japanese Journal of Applied Physics*, vol. 57, no. 6S3, p. 06KC02, 2018.

D. Kang and H. Shin, "Improving the cell characteristics using arch- active profile in nand flash memory having 60 nm design-rule," *Solid-state electronics*, vol. 54, no. 11, pp. 1263–1268, 2010.

C.T.Dabhi and G.C.Patil, "Underlap channel silicon-on-insulator quantum dot floating-gate mosfet for low-power memory applications," *Journal of Computational Electronics*, vol. 15, no. 4, pp. 1563–1569, 2016.

R. Dhavse, K. Prashant, C. Dabhi, A. Darji, and R. Patrikar, "Fabrication and investigation of low-voltage programmable flash memory gate stack," in *Proceedings of the International Conference on Microelectronics, Computing & Communication Systems*. Springer, 2018, pp. 35–49.

P. Pavan, L. Larcher, and A. Marmiroli, *Floating gate devices: operation and compact modeling*. Springer Science & Business Media, 2007.

T. Ikegami, K. Fukuda, J. Hattori, H. Asai, and H. Ota, "A tcad device simulator for exotic materials and its application to a negative-capacitance fet," *Journal of Computational Electronics*, vol. 18, no. 2, pp. 534–542, 2019.

F.R. Palomo Pinto, Y.Gurimskaya, E.G.Villani, M.Moll, J.Schwandt, and R. Millán, "Sissa: Tcad device simulations of irradiated silicon detectors," *PoS*, p. 051, 2020.

K. Ko, J. K. Lee, M. Kang, J. Jeon, and H. Shin, "Prediction of process variation effect for ultra-scaled gaa vertical fet devices using a machine learning approach," vol. 66, no. 10. *IEEE*, 2019, pp. 4474–4477.

J. Hattori, T. Ikegami, and K. Fukuda, "Technology computer-aided design simulation of phonon heat transport in semiconductor devices," *Japanese Journal of Applied Physics*, vol. 60, no. SB, p. SBBA03, 2021.

T.Dutta, C.Medina-Bailon, A.Rezaei, D.Nagy, F.Adamu-Lema, N.Xeni, Y. Abourrig, N. Kumar, V. P. Georgiev, and A. Asenov, "Tcad simulation of novel semiconductor devices," pp. 1–4, 2021.

J. E. Sanchez and Q. Chen, "Element edge-based discretization for tcad device simulation," *IEEE Transactions on Electron Devices*, vol. 68, no. 11, pp. 5414–5420, 2021.

S. Chiu, Y. Xu, X. Ji, Y. Liao, F. Wu, and F. Yan, "An advanced tunnel oxide layer process for 65 nm nor floating-gate flash memories," *Semiconductor Science and Technology*, vol. 30, no. 10, p. 105032, 2015.

S. Chiu, Y. Xu, X. Ji, and F. Yan, "Investigation of impact of post- metallization annealing on reliability of 65 nm nor floating-gate flash memories," *Solid-State Electronics*, vol. 126, pp. 125–129, 2016.

D. Shum, J. Power, R. Ullmann, E. Suryaputra, K. Ho, J. Hsiao, C. Tan, W. Langheinrich, C. Bukethal, V. Pissors et al., "Highly reliable flash memory with self-aligned split-gate cell embedded into high performance 65nm cmos for automotive & smartcard applications," in 2012 4th IEEE International Memory Workshop. IEEE, 2012, pp. 1–4.

D. Kang and H. Shin, "Improving the cell characteristics using arch-active profile in nand flash memory having 60 nm design-rule," *Solid-state electronics*, vol. 54, no. 11, pp. 1263–1268, 2010.

G.Servalli, D.Brazzelli, E.Camerlenghi, G.Capetti, S.Costantini, C.Cupeta, D. DeSimone, A. Ghetti, T. Ghilardi, P. Gulli et al., "A 65nm nor flash technology with 0.042/spl mu/m/sup 2/cell size for high performance multilevel application," in IEEE International Electron Devices Meeting, 2005. IEDM Technical Digest. IEEE, 2005, pp. 849–852.

E. Bestelink, O. de Sagazan, L. Motte, M. Bateson, B. Schultes, S. R. P. Silva, and R. A. Sporea, "Versatile thin-film transistor with independent control of charge injection and transport for mixed signal and analog computation," *Advanced Intelligent Systems*, vol. 3, no. 1, p. 2000199, 2021.

S.Agarwal, D.Garland, J.Niroula, R.B.Jacobs-Gedrim, A.Hsia, M.S. Van Heukelom, E. Fuller, B. Draper, and M. J. Marinella, "Using floating- gate memory to train ideal accuracy neural networks," *IEEE Journal on Exploratory Solid-State Computational Devices and Circuits*, vol. 5, no. 1, pp. 52–57, 2019.

T. Kim, K. Park, T. Jang, M.-H. Baek, Y. S. Song, and B.-G. Park, "Input- modulating adaptive neuron circuit employing asymmetric floating-gate mosfet with two independent control gates," *Solid-State Electronics*, vol. 163, p. 107667, 2020.

S. Sahoo, "Conduction and switching behavior of e-beam deposited poly- crystalline nb2o5 based nano-ionic memristor for non-volatile memory applications," *Journal of Alloys and Compounds*, vol. 866, p. 158394, 2021.

"The international technology roadmap for semiconductors (itrs),"2013.

The 3<sup>rd</sup> International Workshop on Engineering Physics, IC-MEMS-Sensors and  
Their Applications (3<sup>rd</sup>IWEMA2022)  
November-25&26,2022; Ho Chi Minh City, Vietnam

*Host by Faculty of Physics- Engineering Physic, University of Science ,  
Vietnam National University- HCMC)  
and Ono Lab, Tohoku University, Sendai, Japan*

**ORAL SESSION (Session 2, Code: OR-04)**

**1.About speaker**

Title of talk: A simulated fabrication and characterization of a 65 nm floating-gate MOS transistor

Author (s): Dang Cong Thinh, Ton That Bao Phuc and Hoang Trang

Institution (s): Department of Electronics Engineering, Ho Chi Minh City University of Technology (HCMUT), Vietnam National University

Country: Vietnam

Speaker: Dang Cong Thinh

Academic title: Ph.D. student.

Your presentation (please select and put X):

- Plenary talk                       Invited talk  
 Oral Presentation                       Poster Presentation

E-mail: dcthinh.sdh20@hcmut.edu.vn    Handphone: +84 984788459

**2. Your Abstract**

Abstract:

The aim of this study was to virtual fabricate and characterize a Floating-gate MOS transistor of the 65 nm process. The fabrication process was designed and characterized using the TCAD Silvaco tools. In our work, a detailed flow and the parameters are proposed to virtual fabricate the complete Floating-gate MOS transistor, which has extraordinary performances. The MOS has a large timing window of 4 V, a high gate capacitance ratio parameter of 0.645, and a high Write/Erase speed of 50 ms/70 ms. Interestingly, the results

are obtained with a thin thickness of 9 nm of a tunnel oxide layer which is smaller than such layer in other works and low supply voltages in which the control gate, drain, and source voltage values are  $\pm 6$  V, 1 V, and 1 V, respectively. In addition, our paper presents the effect of the control gate voltage on the performance of the device when it increases from 6 V to 18 V.

\*Keywords: Floating-gate MOS, Flash memory cell, Tunnelling effects, CMOS technology, Gate leakage current, TCAD tool

\*References:

- Wang S, He C, Tang J, Lu X, Shen C, Yu H, Du L, et al., Nonvolatile memory: New floating gate memory with excellent retention characteristics (adv. electron. mater. 4/2019), Adv Electron Mater 2019;5 (4): 1970018.
- Agarwal S, Garland D, Niroula J, Jacobs-Gedrim RB, Hsia A, Van Heukelom MS, Fuller E, Draper B, Marinella MJ. Using floating-gate memory to train ideal accuracy neural networks. IEEE J Explorat Solid-State Comput Dev Circ 2019;5 (1):52–7.
- Wunderlich RB, Adil F, Hasler P. Floating gate-based field programmable mixed-signal array. IEEE Trans Very Large Scale Integr (VLSI) Syst 2012;21 (8):1496–505.
- Kim T, Park K, Jang T, Baek M-H, Song YS, Park B-G. Input-modulating adaptive neuron circuit employing asymmetric floating-gate mosfet with two independent control gates. Solid-State Electron 2020; 163:107667.
- Saheb Z, El-Masry EI. Modelling of direct tunneling gate leakage current of floating gate cmos transistor in sub 100 nm technologies. Analog Integr Circ Signal Process 2015;84(1):67–73.
- The international technology roadmap for semiconductors (itrs), 2013.
- Saheb Z, El-Masry E. Practical simulation model of floating-gate mos transistor in sub 100nm technologies. Int J Electr, Comput, Energetic, Electron Commun Eng 9 (8).
- Tseng JM, Pedron T. A new method to extract gate coupling ratio and oxide trapped charge in flash memory cell. Microelectron Eng 2006;83(2):218–20.
- Dabhi CT, Patil GC. Underlap channel silicon-on-insulator quantum dot floating-gate mosfet for low-power memory applications. J Comput Electron 2016;15(4):1563–9.
- R. Dhavse, K. Prashant, C. Dabhi, A. Darji, R. Patrikar, Fabrication and investigation of low-voltage programmable flash memory gate stack, in: Proceedings of the International Conference on Microelectronics, Computing & Communication Systems, Springer, 2018, pp. 35–49.
- Chiu S, Xu Y, Ji X, Liao Y, Wu F, Yan F. An advanced tunnel oxide layer process for 65 nm nor floating-gate flash memories. Semicond Sci Technol 2015;30 (10):105032.
- Chiu S, Xu Y, Ji X, Yan F. Investigation of impact of post-metallization annealing on reliability of 65 nm nor floating-gate flash memories. Solid-State Electron 2016; 126:125–9.
- D. Shum, J. Power, R. Ullmann, E. Suryaputra, K. Ho, J. Hsiao, C. Tan, W. Langheinrich, C. Bukethal, V. Pissors, et al., Highly reliable flash memory with self-

aligned split-gate cell embedded into high performance 65nm cmos for automotive & smartcard applications, in 2012 4th IEEE International Memory Workshop, IEEE, 2012, pp. 1–4.

- Hamzah A, Alias NE, Ismail R. Low-voltage high-speed programming gate-all-around floating gate memory cell with tunnel barrier engineering. *Japan J Appl Phys* 2018;57(6S3):06KC02.
- A. Misra, H. Kalita, M. Waikar, A. Gour, M. Bhaisare, M. Khare, M. Aslam, A. Kottantharayil, Multilayer graphene as charge storage layer in floating gate flash memory, in 2012 4th IEEE International Memory Workshop, IEEE, 2012, pp. 1–4.
- Bertolazzi S, Krasnozhon D, Kis A. Nonvolatile memory cells based on mos2/graphene heterostructures. *ACS nano* 2013;7(4):3246–52.
- Kang D, Shin H. Improving the cell characteristics using arch-active profile in nand flash memory having 60 nm design-rule. *Solid-state Electron* 2010;54(11):1263–8.
- G. Servalli, D. Brazzelli, E. Camerlenghi, G. Capetti, S. Costantini, C. Cupeta, D. DeSimone, A. Ghetti, T. Ghilardi, P. Gulli, et al., A 65nm nor flash technology with 0.042/spl mu/m/sup 2/cell size for high performance multilevel application, in: IEEE International Electron Devices Meeting, 2005. IEDM Technical Digest., IEEE, 2005, pp. 849–852.
- D. Wellekens, P. Blomme, M. Rosmeulen, T. Schram, A. Cacciato, I. Debusschere, S. Van Aerde, J. Van Houdt, An ultra-thin hybrid floating gate concept for sub- 20nm nand flash technologies, in 2011 3rd IEEE International Memory Workshop (IMW), IEEE, 2011, pp. 1–4.
- De Blauwe J. Nanocrystal nonvolatile memory devices. *IEEE Trans Nanotechnol* 2002;1(1):72–7. doi: <https://doi.org/10.1109/TNANO.2002.1005428>.
- Hamzah A, Ahmad H, Tan MLP, Alias NE, Johari Z, Ismail R. Scaling challenges of floating gate non-volatile memory and graphene as the future flash memory device: a review. *J Nanoelectron Optoelectron* 2019;14(9):1195–214.
- Ali T, Polakowski P, Büttner T, Kämpfe T, Rudolph M, Pätzold B, Hoffmann R, Czernohorsky M, Kühnel K, Steinke P, et al. Theory and experiment of antiferroelectric (afe) si-doped hafnium oxide (hso) enhanced floating-gate memory. *IEEE Trans Electron Dev* 2019;66(8):3356–64.
- S.N. Keeney, Dielectric scaling challenges and approaches in floating gate non- volatile memories, in: Proceedings-electrochemical society, 2004, pp. 151–158.
- Larcher L, Pavan P, Pietri S, Albani L, Marmiroli A. A new compact dc model of floating gate memory cells without capacitive coupling coefficients. *IEEE Trans Electron Dev* 2002;49(2):301–7.
- B.S. Kalyan, B. Singh, Design and simulation equivalent model of floating gate transistor, in 2015 Annual IEEE India Conference (INDICON), IEEE, 2015, pp. 1–6.
- Cao W, Kang J, Bertolazzi S, Kis A, Banerjee K. Can 2d-nanocrystals extend the lifetime of floating-gate transistor based nonvolatile memory? *IEEE Trans Electron Dev* 2014;61(10):3456–64.
- J. An, J.-L. Maurice, V. Depauw, P.R. i Cabarrocas, W. Chen, Impact of pecvd- prepared interfacial si and sige layers on epitaxial si films grown by pecvd (200 c) and apcvd (1130 c), *Applied Surface Science* 546 (2021) 149056.
- H. Kim, K. Lu, Y. Liu, H.S. Kum, K.S. Kim, K. Qiao, S.-H. Bae, S. Lee, Y.J. Ji, K.H. Kim, et al., Impact of 2d–3d heterointerface on remote epitaxial interaction through graphene, *ACS nano*.
- Jaeger RC. Introduction to microelectronic fabrication, Addison-Wesley Longman Publishing Co., Inc., 2002.

- Baker RJ. CMOS: circuit design, layout, and simulation. John Wiley & Sons; 2019.
- Lee M, Cho S, Lee N, Kim J. Radiation-tolerance analysis of i-gate n-mosfet according to isolation oxide module in the cmos bulk process. Microelectron Eng 2018; 200:45–50.
- Garetto D, Dornel E, Hniki S, Rideau D, Clark W, Schmid A, Tavernier C, et al. Analytical and compact models of the ono capacitance in embedded nonvolatile flash devices. In: European Solid-State Devices and Technologies Conference, ESSDERC/ESSCIRC Fringe Poster Session, no. CONF; 2009.
- Chen H, Zhou Y, Han ST. Recent advances in metal nanoparticle-based floating gate memory, Nano Select.

### 3. Your fullpaper to publish in the Journal

In case of publication in Journal, please send your manuscript (full paper) to 3<sup>rd</sup> IWEMA2022 (email address:3iwema2022@gmail.com) before December 25, 2022.

Please select one of the below Journals for the process review for your publication as (put X) :

. **Applied Science** (*an Open Access Journal from MDPI, Journal Rank: Q2-Engineering, Multidisciplinary*);

. **IEEJ** (*Transactions on Sensors and Micromachines/Transactions on Electronics, Information and Systems: Q3/Q4*);

. Journal of **IKEEE** (Korea, non-Scopus);

. **VNUHCM Press** (Vietnam National University- Ho Chi Minh city; non-Scopus);

Please submit your registration and abstract (around 200 words) to [3iwema2022@gmail.com](mailto:3iwema2022@gmail.com) before **November 10<sup>th</sup>, 2022**.

Full paper for review process and Publications: 5-10 pages (as sample) before **December 15, 2022**.

The 3<sup>rd</sup> International Workshop on Engineering Physics, IC-MEMS-Sensors and  
Their Applications (3<sup>rd</sup>IWEMA2022)  
November-25&26,2022; Ho Chi Minh City, Vietnam

*Host by Faculty of Physics- Engineering Physic, University of Science ,  
Vietnam National University- HCMC)  
and Ono Lab, Tohoku University, Sendai, Japan*

**PARALLEL SESSION**  
**(Session 3, code: OR-05)**

-----

**1.About speaker:**

Title of talk: Low power circuit design using NCL based asynchronous method

Author (s): Truong Tri Lac, Le Thanh Toi and Hoang Trang

Institution (s): Ho Chi Minh City University of Technology (HCMUT), Ho Chi Minh City

Country: Vietnam

Speaker: Truong Tri Lac

Academic title: Ph.D student, researcher

E-mail: ttlac.sdh20@hcmut.edu.vn

Handphone: 0978614508

**2. Abstract:**

The Null Convention Logic (NCL) based circuit design methodology eliminates the problems related to noise, clock tree, electromagnetic interference and also reduces significant power consumption. In this paper, we would like to demonstrate the advantage of low power consumption of the NCL based asynchronous circuit design on a large design scale, thus we used the AES (Advanced Encryption Standard) encryption design as an illustrative example. In addition, we also proposed two pipelined AES encryption models using the synchronous circuit design technique and the asynchronous circuit design technique based on NCL. Besides, these two models were realized by using VCS tool to simulate and Design Compiler tool to synthesize parameters in power consumption, processing speed and area. The synthesis results of these two models indicated that power consumption of the NCL based asynchronous AES encryption model had a decrease of 71 % compared with the synchronous AES encryption model. Moreover, we show the outstanding advantage of the power consumption of the NCL based asynchronous design

model (a decrease of 91.12% and 93,23%) compared to the synchronous design model using clock gating technique and without using clock gating technique respectively.

\*Keywords: Null Convention Logic (NCL), Asynchronous method, Synchronous method, Advanced Encryption Standard (AES), Low power;

\*References:

Jun Wu, "Null Convention Logic applications of asynchronous design in nanotechnology and cryptographic security," Dissertation, Missouri university of science and technology, 2012.

B. Padmavathi, *et al.*, "Low Power Design Techniques and implementation Strategies Adopted in VLSI Circuits," IEEE International Conference on Power, Control, Signals and Instrumentation Engineering (ICPCSI-2017), 2017.

Md. Zakir Hussain<sup>1</sup>, K. N. Parvin, "Low power and high performance FFT with different radices," International Journal of Reconfigurable and Embedded Systems (IJRES), Vol. 8, pp. 99-106, 2019.

M. Saber, *et al.*, "Low power pseudo-random number generator based on lemniscate chaotic map," Vol.11, pp. 863-871, February 2021.

Yan Chiew Wong, *et al.*, "Low power wake-up receiver based on ultrasound communication for wireless sensor network," Vol. 9, pp. 21-29, 2020.

Pham-Khoi Dong, *et al.*, "Low-Power Implementation of a High-Throughput Multi-core AES Encryption Architecture", *the 2020 IEEE Asia Pacific Conference on Circuits and Systems (APCCAS)*, 2020.

K. Haulmark, "Comprehensive Comparison of NULL Convention Logic Threshold Gate Implementations," *2018 New Generation of CAS (NGCAS)*, 2018

B. G. Fawzy, *et al.*, "Strong Indication Full-Adder Circuit for NULL Convention Logic Automation Flows," *2018 18th International Symposium on Communications and Information Technologies*, 2018.

A. J. Albert and S. Ramachandran, "Static Implementation Of A Null Convention Logic Based Exponent Adder," *International Journal of Applied Engineering Research*, Vol. 10, pp. 7601-7614, 2015.

A. Caberos, *et al.*, "Area-Efficient CMOS Implementation of NCL Gates for XOR-AND/OR Dominated Circuits," *IEEE Asia Pacific Conference on Postgraduate Research in Microelectronics and Electronics*, 2017

D. L. Oliveira, *et al.*, "Novel Area-efficient Null Convention Logic based on CMOS and Gate Diffusion Input (GDI) Hybrid," *Journal of semiconductor technology and science*, vol. 20, pp. 127-134, 2020.

N. L. Huy, *et al.*, "Null Convention Logic Primitive Element Architecture for Ultralow Power High Performance Portable Digital Systems," *2017 IEEE Regional Symposium on Micro and Nanoelectronics (RSM)*, 2017.

M. Howard, *et al.*, "Investigation and Comparison of Bus Alternatives for Asynchronous Circuits," *SoutheastCon 2018*, 2018.

D. V. Supriya and M. R. Niranjana, "Realization of AES Encryption and Decryption Based On Null Convention Logic," *International Research Journal of Engineering and Technology*, Vol. 02, pp. 77-81, 2015

R. M. Sovani, "Near and Sub-Threshold Null Convention Logic Design for Low-power Digital Signal Processing Applications," Dissertation, RMIT University, 2016.

- N. Kulkarni, "Energy-Efficient Digital Circuit Design using Threshold Logic Gates," Dissertation, Arizona State University, 2015.
- A. Bailey, *et al.*, "Silicon On Insulator Null Convention Logic based asynchronous circuit design for high performance low power digital systems," *2018 2nd International Conference on Recent Advances in Signal Processing, Telecommunications & Computing (SigTelCom)*, 2018
- L. Oliveira, *et al.*, "A novel NULL Convention Logic (NCL) Gates Architecture based on Basic Gates," *2017 IEEE XXIV International Conference on Electronics, Electrical Engineering and Computing*, 2017
- A. Vakil, *et al.*, "Comparitive Analysis of Null Convention Logic and Synchronous CMOS Ripple Carry Adders", *2017 Second International Conference on Electrical, Computer and Communication Technologies*, 2017.
- S. D. Putra, "Revealing AES Encryption Device Key on 328P Microcontrollers with Differential Power Analysis," *International Journal of Electrical and Computer Engineering (IJECE)*, vol. 08, pp. 5144-5152, December 2018.
- A. M. Abdullah, "Advanced Encryption Standard (AES) Algorithm to Encrypt and Decrypt Data," Eastern Mediterranean University – Cyprus, 2017.
- D. Swathi, *et al.*, "Designing of S-Box Based On Null Convention Logic," *International Research Journal of Engineering and Technology*, Vol. 02, pp. 71 – 76, 2015.
- L. P. Kumar, "Implementation of Speech Encryption and Decryption using Advanced Encryption Standard," *IEEE International Conference On Recent Trends In Electronics Information Communication Technology*, 2016.
- Neil H. E. Weste, David Money Harris, "CMOS VLSI Design a Circuits and Systems Perspective," 4th Edition, Addison Wesley, 2010.
- L. D. Tran, *et al.*, "Null Convention Logic (NCL) based Asynchronous Design – Fundamentals and Recent Advances," *2017 International Conference on Recent Advances in Signal Processing, Telecommunications & Computing*, 2017.
- R. Sankar, *et al.*, "Implementation of Static and Semi-Static Versions of a Bit-Wise Pipelined Dual-Rail NCL 2S Complement Multiplier," *2007IEEE Region 5 Technical Conference*, 2007.
- A. J. Albert and S. Ramachandran , "NULL Convention Floating Point Multiplier, " *The Scientific World Journal*, 2015.
- Ahmed Zaky, *et al.*, "Ultra Low-Power Encryption/Decryption Core for Lightweight IoT Applications," *2019 15th International Computer Engineering Conference (ICENCO)*

The 3<sup>rd</sup> International Workshop on Engineering Physics, IC-MEMS-Sensors and  
Their Applications (3<sup>rd</sup>IWEMA2022)  
*November-25&26,2022; Ho Chi Minh City, Vietnam*

*Host by Faculty of Physics- Engineering Physic, University of Science ,  
Vietnam National University- HCMC)  
and Ono Lab, Tohoku University, Sendai, Japan*

**ORAL SESSION (Session 5, Code: OR-06)**

**1.About speaker**

Title of talk: **Coulomb drag in double-layer gapped graphene systems**

Author (s): Dong Thi Kim Phuong and Nguyen Van Men

Institution (s): *An Giang University – VNU HCM, 18-Ung Van Khiem Street, Long Xuyen  
City, An Giang Province; Vietnam National University, Ho Chi Minh City.*

Country: *Vietnam*

Speaker: Nguyen Van Men

Academic title: Ph.D, Lecturer

E-mail: [nvmen@agu.edu.vn](mailto:nvmen@agu.edu.vn) Handphone: 0902 657 975

**2. Abstract**

We theoretically investigate Coulomb drag in a double-layer system consisting of two parallel gapped graphene sheets, separated by dielectric spacers. In calculations, we employ the random-phase approximation to determine the polarizability functions of gapped graphene layers and the dynamical dielectric function of the structure. Our numerical calculations demonstrate that Coulomb drag in double-layer gapped graphene systems steadily increases as temperature increases but quickly decreases with the increase in interlayer separation. The drag resistivity between two layers is only pronounced with sufficiently small interlayer distances. In regions of small interlayer separations, Coulomb drag behaves as a smoothly increasing function of the bandgap. However, with sufficiently large separations, Coulomb drag increases with small bandgaps but decreases with larger

ones. We obtain that a finite bandgap significantly contributes to the frictional drag phenomenon, therefore it should be taken into account in calculations to improve the model.

\*Keywords (5): *Bandgap; Coulomb drag; Double-layer structures; Gapped graphene.*

\*References:

- [1] F. Parhizgar and R. Asgari, "Magnetoresistance of a double-layer hybrid system in a tilted magnetic field," *Physical Review B*, vol. 90, p. 035438, 2014.
- [2] E. Ş. Tüzemen, A. Turkoglu, Y. Ergun, I. Sokmen, and B. Tanatar, "Effect of exchange–correlation potential on the plasmon dispersions in a doped symmetrical double quantum well," *Physica Status Solidi B*, vol. 244, no. 2, p. 635, 2007.
- [3] B. Tanatar and B. Davoudi, "Dynamic correlations in double-layer electron systems," *Physical Review B*, vol. 63, p. 165328, 2003.
- [4] T. Stauber and G. Gómez-Santos, "Plasmons and near-field amplification in double-layer graphene," *Physical Review B*, vol. 85, p. 075410, 2012.
- [5] G. E. Santoro and G. F. Giuliani, "Acoustic plasmons in a conducting double layer," *Physical Review B*, vol. 37, no. 2, p. 937, 1988.
- [6] V. Ryzhii, A. Satou, T. Otsuji, M. Ryzhii, V. Mitin, and M. S. Shur, "Dynamic effects in double graphene-layer structures with inter-layer resonant-tunneling negative conductivity," *Journal of Physics D: Applied Physics*, vol. 46, p. 315107, 2013.
- [7] V. Ryzhii *et al.*, "Effect of plasma resonances on dynamic characteristics of double graphene-layer optical modulator," *Journal of Applied Physics*, vol. 112, p. 104507, 2012.
- [8] V. Ryzhii, M. Ryzhii, V. Mitin, M. S. Shur, A. Satou, and T. Otsuji, "Injection terahertz laser using the resonant inter-layer radiative transitions in double-graphene-layer structure," *Applied Physics Letters*, vol. 103, p. 163507, 2013.
- [9] V. Ryzhii, M. Ryzhii, V. Mitin, M. S. Shur, A. Satou, and T. Otsuji, "Terahertz photomixing using plasma resonances in double-graphene layer structures," *Journal Of Applied Physics*, vol. 113, p. 174506, 2013.
- [10] N. V. Men and D. T. K. Phuong, "Plasmon modes in double-layer gapped graphene at zero temperature," *Physics Letters A*, vol. 384, p. 126221, 2020.
- [11] N. V. Men, N. Q. Khanh, and D. T. K. Phuong, "Plasmon modes in double-layer gapped graphene," *Physica E*, vol. 118, p. 113859, 2020.
- [12] N. V. Men, N. Q. Khanh, and D. T. K. Phuong, "Plasmon modes in double bilayer graphene heterostructures," *Solid State Communications*, vol. 294, p. 43, 2019.
- [13] X.-H. Liu, X.-H. Wang, and B.-Y. Gu, "Effects of interwell coupling on plasmon modes in symmetric double square quantum well structures," vol. 64, p. 195322, 2001.
- [14] E. H. Hwang and S. DasSarma, "Exotic plasmon modes of double layer graphene," *Physical Review B*, vol. 80, p. 205405, 2009.
- [15] K. Guven and B. Tanatar, "Coupled plasmon-phonon mode effects on the Coulomb drag in double-quantum-well systems," *Physical Review B*, vol. 56, no. 12, p. 7535, 1997.
- [16] K. Flensberg and B. Y.-K. Hu, "Plasmon enhancement of Coulomb drag in double-quantum-well systems," *Physical Review B*, vol. 52, p. 14796, 1995.
- [17] N. Dadkhah, T. Vazifehshenas, M. Farmanbar, and T. Salavati-fard, "A theoretical study of collective plasmonic excitations in double-layer silicene at finite temperature," *Journal of Applied Physics*, vol. 125, p. 104302, 2019.
- [18] P. G. Bolcatto and C. R. Proetto, "Collective Modes in Semiconductor Double Quantum Well Systems," *Physica Status Solidi B*, vol. 220, p. 65, 2000.
- [19] E. H. Hwang and S. DasSarma, "Dielectric function, screening, and plasmons in two-dimensional graphene," *Physical Review B*, vol. 75, p. 205418, 2007.

- [20] S. DasSarma, E. H. Hwang, and E. Rossi, "Theory of carrier transport in bilayer graphene," *Physical Review B*, vol. 81, p. 161407, 2010.
- [21] M. I. Katsnelson, *Graphene: Carbon in Two Dimensions*. New York: Cambridge University Press, 2012.
- [22] B. Y. Jiang *et al.*, "Plasmon reflections by topological electronic boundaries in bilayer graphene," *Nano Letters* vol. 17, p. 7080, 2017.
- [23] M. Jablan, M. Soljačić, and H. Buljan, "Plasmons in Graphene: Fundamental Properties and Potential Applications," in *Proceedings of the IEEE*, 2013, vol. 11, no. 7, p. 1689.
- [24] A. N. Grigorenko, M. Polini, and K. S. Novoselov, "Graphene plasmonics," *Nature Photonics*, Review Article vol. 6, p. 749, 11/05/online 2012.
- [25] A. K. Geim and K. S. Novoselov, "The rise of graphene," *Nature Mater*, vol. 6, p. 183, 2007.
- [26] A. K. Geim and A. H. MacDonald, "Graphene: Exploring carbon flatland," *Physics Today*, vol. 60, p. 35, 2007.
- [27] F. J. Garcia-de-Abajo, "Graphene plasmonics: challenges and opportunities," *ACS Photonics*, vol. 1, p. 135, 2014.
- [28] P. K. Pyatkovskiy, "Dynamical polarization, screening, and plasmons in gapped graphene," *Journal of Physics: Condensed Matter*, vol. 21, p. 025506, 2009.
- [29] D. K. Patel, S. S. Z. Ashraf, and A. C. Sharma, "Temperature dependent screened electronic transport in gapped graphene," *Physica Status Solidi B*, vol. 252, no. 8, p. 1817, 2015.
- [30] D. K. Patel, S. S. Z. Ashraf, and A. C. Sharma, "Finite temperature dynamical polarization and plasmons in gapped graphene," *Physica Status Solidi B*, vol. 252, no. 2, p. 282, 2015.
- [31] N. V. Men, "Plasmon modes in N-layer gapped graphene," *Physica B*, vol. 578, p. 411876, 2020.
- [32] A. Iurov, G. Gumbs, D. Huang, and V. M. Silkin, "Plasmon dissipation in gapped graphene open systems at finite temperature," *Physical Review B*, vol. 93, p. 035404, 2016.
- [33] S. Kim, I. Jo, J. Nah, Z. Yao, S. K. Banerjee, and E. Tutuc, "Coulomb drag of massless fermions in graphene," *Physical Review B*, vol. 83, p. 161401(R), 2011.
- [34] P. Simonet *et al.*, "Anomalous Coulomb drag between bilayer graphene and a GaAs electron gas," *New Journal of Physics*, vol. 19, p. 03042, 2017.
- [35] K. Lee, J. Xue, D. C. Dillen, K. Watanabe, T. Taniguchi, and E. Tutuc, "Giant Frictional Drag in Double Bilayer Graphene Heterostructures," *Physical Review Letters*, vol. 117, p. 046803, 2016.
- [36] D. Y. H. Ho, I. Yudhistira, B. Y.-K. Hu, and S. Adam, "Theory of Coulomb drag in spatially inhomogeneous 2D materials," *Communications Physics*, vol. 1, p. 41, 2018.
- [37] M. Carrega, T. Tudorovskiy, A. Principi, M. I. Katsnelson, and M. Polini, "Theory of Coulomb drag for massless Dirac fermions," *New Journal of Physics*, vol. 14, p. 063033, 2012.
- [38] M. I. Katsnelson, "Coulomb drag in graphene single layers separated by a thin spacer," *Physical Review B*, vol. 84, p. 041407(R), 2011.
- [39] B. Scharf and A. Matos-Abiague, "Coulomb drag between massless and massive fermions," *Physical Review B*, vol. 86, p. 115425, 2012.
- [40] S. Adam and S. DasSarma, "Boltzmann transport and residual conductivity in bilayer graphene," *Physical Review B*, vol. 77, p. 115436, 2008.
- [41] A. Principi, M. Carrega, R. Asgari, V. Pellegrini, and M. Polini, "Plasmons and Coulomb drag in Dirac/Schrodinger hybrid electron systems," *Physical Review B*, vol. 86, p. 085421, 2012.

- [42] A. Principi, M. Carrega, R. Asgari, V. Pellegrini, and M. Polini, "Plasmons and Coulomb drag in Dirac-Schrodinger hybrid electron systems," *Physical Review B*, vol. 86, p. 085421, 2012.
- [43] A. Gamucci *et al.*, "Anomalous low-temperature Coulomb drag in graphene-GaAs heterostructures," *Nature Commun*, vol. 5, p. 5824, 2014.
- [44] S. M. Badalyan and F. M. Peeters, "Enhancement of Coulomb drag in double-layer graphene structures by plasmons and dielectric background inhomogeneity," *Physical Review B*, vol. 86, p. 121405(R), 2012.
- [45] S. K. Upadhyay and L. K. Saini, "Coulomb drag study in graphene/GaAs bilayer system with the effect of local field correction and dielectric medium," *Physica E*, vol. 127, p. 114484, 2021.
- [46] S. K. Upadhyay and L. K. Saini, "Coulomb drag study in electron-electron bilayer system with a dielectric medium," *Physica E*, vol. 124, p. 114350, 2020.
- [47] J. I. A. Li, T. Taniguchi, K. Watanabe, J. Hone, A. Levchenko, and C. R. Dean, "Negative Coulomb Drag in Double Bilayer Graphene," *Physical Review Letters*, vol. 117, p. 046802, 2016.
- [48] W.-K. Tse, B. Y.-K. Hu, and S. DasSarma, "Theory of Coulomb drag in graphene," *Physical Review B*, vol. 76, p. 081401(R), 2007.
- [49] K. Flensberg, B. Y.-K. Hu, and A.-P. Jauho, "Linear-response theory of Coulomb drag in coupled electron systems," *Physical Review B*, vol. 52, no. 20, p. 14761, 1995.
- [50] B. Amorim and N. M. R. Peres, "On Coulomb drag in double layer systems," *Journal Of Physics: Condensed Matter*, vol. 24, p. 335602, 2012.
- [51] T. Vazifeshenas, T. Amlaki, M. Farmanbar, and F. Parhizgar, "Temperature effect on plasmon dispersions in double-layer graphene systems," *Physics Letters A*, vol. 374, no. 48, p. 4899, 2010.
- [52] D. V. Tuan and N. Q. Khanh, "Plasmon modes of double-layer graphene at finite temperature," *Physica E*, vol. 54, p. 267, 2013.

The 3<sup>rd</sup> International Workshop on Engineering Physics, IC-MEMS-Sensors and  
Their Applications (3<sup>rd</sup>IWEMA2022)  
November-25&26,2022; Ho Chi Minh City, Vietnam

*Host by Faculty of Physics- Engineering Physic, University of Science ,  
Vietnam National University- HCMC)  
and Ono Lab, Tohoku University, Sendai, Japan*

**ORAL SESSION (Session 1, Code: OR-01)**

**1.About speaker**

Title of talk: Tunable frequency of overhang-shaped cantilevers

Author (s): Le Tri Dat<sup>1</sup>, Nguyen Duy Vy<sup>2</sup> and Amir F. Payam<sup>3</sup>

Institution (s): <sup>1</sup>Ton Duc Thang University, <sup>2</sup>Van Lang University, <sup>3</sup>Ulster University

Country: Vietnam

Speaker: Nguyen Duy Vy

Academic title: Doctor of Engineering

E-mail: nguyenduyvy@vlu.edu.vn      Handphone:.(+84) 916 10 0202

**2. Abstract**

**TUNABLE FREQUENCY OF OVERHANG-SHAPED CANTILEVERS**

Le Tri Dat<sup>1,2,\*</sup>, Nguyen Duy Vy<sup>3,4,†</sup>, Amir F. Payam<sup>5</sup>

<sup>1</sup>Computational Laboratory for Advanced Materials and Structures, Advanced Institute of Materials Science, Ton Duc Thang University, Ho Chi Minh City, Vietnam

<sup>2</sup>Faculty of Applied Sciences, Ton Duc Thang University, Ho Chi Minh City, Vietnam

<sup>3</sup>Laboratory of Applied Physics, Science and Technology Advanced Institute, Van Lang University, Ho Chi Minh City, Vietnam

<sup>4</sup>Faculty of Technology, Van Lang University, Ho Chi Minh City, Vietnam

<sup>5</sup>School of Engineering, Ulster University, Co. Antrim, UK

\*letridat@tdtu.edu.vn, †nguyenduyvy@vlu.edu.vn

Width-varying cantilevers for detecting of objects at micro and nanoscale have been of great interest recently. Beside the T-shaped cantilevers that uses the torsional modes accompanying with the flexural mode to enhance the flexibility and versatility of detecting regime, the overhang-shaped cantilevers also have interesting characteristics that could be

used to improve measurement ability and sensitivity. In this presentation, we show that the frequency of the overhang-shaped cantilevers could be controlled by changing the dimensions (length and width) of the overhang part that connecting the cantilever to the substrate. The tunability is dependent on the mode number and strongly dependent on the relative dimensions of the overhang and the main cantilever. This finding could help to guide the experimentalist in fabricating cantilevers of specific frequency range.

**Keywords:** AFM, coupling strength, frequency equation, microcantilever, overhang-shaped  
**References:**

- Tamayo J., Ramos D., Mertens J., & Calleja M. (2006). Effect of the adsorbate stiffness on the resonance response of microcantilever sensors. *Applied Physics Letters* **89**(22), 224,104. <https://doi.org/10.1063/1.2388925>
- Guillon S., Saya D., Mazonq L., Perisanu S., Vincent P., Lazarus A., Thomas O., & Nicu L. (2011). Effect of non-ideal clamping shape on the resonance frequencies of silicon nanocantilevers. *Nanotechnology* **22**(24), 245,501. <https://doi.org/10.1088/0957-4484/22/24/245501>
- Endo D., Yabuno H., Higashino K., Yamamoto Y., & Matsumoto S. (2015). Self-excited coupled-microcantilevers for mass sensing. *Applied Physics Letters* **106**(22), 223,105. <https://doi.org/10.1063/1.4921082>
- Tri Dat L., Vinh N.T. Pham, Nguyen Duy Vy, Amir. F. Payam (2022), Frequency equation and semi-empirical mechanical coupling strength of microcantilevers in an array, *Microscopy Research Technique* **85**(9), 3237. <http://doi.org/10.1002/jemt.24180>

The 3<sup>rd</sup> International Workshop on Engineering Physics, IC-MEMS-Sensors and  
Their Applications (3<sup>rd</sup>IWEMA2022)  
November-25&26,2022; Ho Chi Minh City, Vietnam

*Host by Faculty of Physics- Engineering Physic, University of Science ,  
Vietnam National University- HCMC)  
and Ono Lab, Tohoku University, Sendai, Japan*

**ORAL SESSION (Session 4, Code: OR-08)**

**1.About speaker**

Title of talk: **Modified Graphene on SiC substrate by plasma treatment for sensing the nitrogen dioxide (NO<sub>2</sub>) gas**

Author (s): Ly Truong Huu<sup>1</sup>, Hoai Duy Tran<sup>1</sup>, Phuong Thanh Nguyen<sup>1</sup>, Tuan Minh Dao<sup>1</sup>, Tuan Quoc Dang<sup>1</sup>, Doanh Tu Tieu<sup>1</sup>, Tham Thi Hong Nguyen<sup>1</sup>, Anh Tuan Nguyen<sup>1</sup>, Thanh Vo Ke Ngo<sup>1</sup>, Tuyet-Mai Tran-Thuy<sup>2</sup>

Institution (s): (1) The Research Laboratories of Saigon High-Tech Park (SHTP-Labs), Ho Chi Minh city, Vietnam

(2) Ho Chi Minh City University of Technology

Country: Vietnam

Speaker: Nguyen Tuan Anh

Academic title: Master

E-mail: anh.nguyentuan@shtplabs.org / nguyentuananh1002@gmail.com

Handphone: 0908781002

**2. Abstract**

At SHTP-Labs, the thin film of graphene was epitaxy growth based on Silicon carbide (SiC) substrate, called Graphene@SiC, by the thermal sublimation method. The morphological characterization of Graphene@SiC was studied by various analysis methods such as SEM/EDX, AFM, STM, ..., and Raman spectroscopy. It introduced the few-layers graphene (FLG) with 2-3 layers of carbon and large-area 5x5 (mm) formed on SiC substrate. To enhance the gas sensing property, the surface of FLG was modified by the plasma treatment.

Using the oxygen plasma, the resistance, sensitivity and selectivity of Graphene@SiC samples changed significantly while exposed to NO<sub>2</sub> gas.

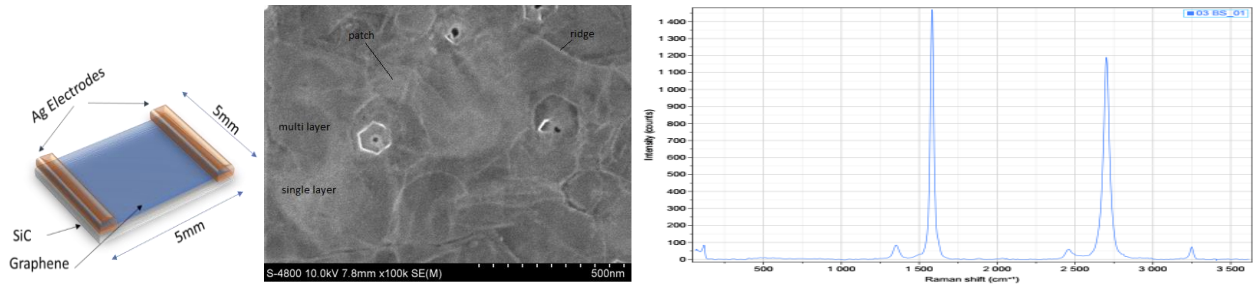

Figure 1: (Left) Structure of NO<sub>2</sub> sensing with two Ag electrodes & (Mid) SEM image and (Right) Raman spectrum of Graphene@SiC

\*Keywords (5): *modified graphene, Graphene@SiC, thermal sublimation, NO<sub>2</sub> sensing, plasma treatment*

\*References:

[1] M. Santhosh, N. et al. N-Graphene Nanowalls via Plasma Nitrogen Incorporation and Substitution: The Experimental Evidence. *Nano-Micro Lett.* 12, 53 (2020).

[2] Chung, M. G. et al. Highly sensitive NO<sub>2</sub> gas sensor based on ozone treated graphene. *Sensors Actuators B Chem.* 166–167, 172–176 (2012).

The 3<sup>rd</sup> International Workshop on Engineering Physics, IC-MEMS-Sensors and  
Their Applications (3<sup>rd</sup>IWEMA2022)  
November-25&26,2022; Ho Chi Minh City, Vietnam

*Host by Faculty of Physics- Engineering Physic, University of Science,  
Vietnam National University- HCMC)  
and Ono Lab, Tohoku University, Sendai, Japan*

**PARALLEL SESSION: Invited talk**  
**(Session 4, code: OR-09)**

**1.About speaker**

Title of talk: A FEM analysis for novel micro-beam structure of high-stress sensitivity of SiC/Si MEMS pressure sensor

Author (s): Nguyen Chi Cuong<sup>(1)</sup>, Braiden Tong<sup>(2)</sup>, Tuan-Hung Nguyen<sup>(2)</sup>, Hong-Quan Nguyen<sup>(2)</sup>, Tuan-Khoa Nguyen<sup>(2)</sup>, Thanh Nguyen<sup>(2)</sup>, Toan Dinh<sup>(2)</sup>, Ngo Vo Ke Thanh<sup>(1)</sup>, Truong Huu Ly<sup>(1)</sup>, Hoang Ba Cuong<sup>(1)</sup>, Trinh Xuan Thang<sup>(1)</sup>, Van Thanh Dau<sup>(2)</sup>, Dzung Viet Dao<sup>(2)</sup>

Institution (s): (1) The Research Laboratories of Saigon High-Tech Park, Vietnam (2) Queensland Micro- and Nanotechnology Centre, Griffith University, QLD, Australia.

Country: (1) Vietnam, (2) Australia

Speaker: Nguyen Chi Cuong

Academic title: Doctor

E-mail: cuong.nguyenchi@shtplabs.org

Handphone: 0985600021

**2. Abstract**

Micro-Mechanical-System (MEMS) pressure sensors on silicon carbide (SiC) are very robust and promising devices due to their excellent mechanical, electronic, thermal, and chemical properties of SiC. In this study, a novel micro-beam structure of a 3C-SiC/Si MEMS pressure sensor is proposed and simulated by the Finite Element Method (FEM) in COMSOL Multiphysics for higher stress amplification in Figure 1. 3C-SiC thin-beam structures are fixed by thick silicon pillars to enhance the sensitivity of pressure sensor in Figure 1. Also, a thin layer of 3C-SiC is fully covered on a side of Si diaphragm which

provides strong protection when the sensors operated on harsh chemically corrosive environments. The novel device used the full Wheatstone bridge to neglect the effect of temperature. Finally, the simulated results showed that 3C-SiC /Si MEMS pressure sensor has high-stress amplification of  $\sim 1.1$  GPa and an output voltage of  $\sim 15$  mV over its pressure range of 50 kPa.

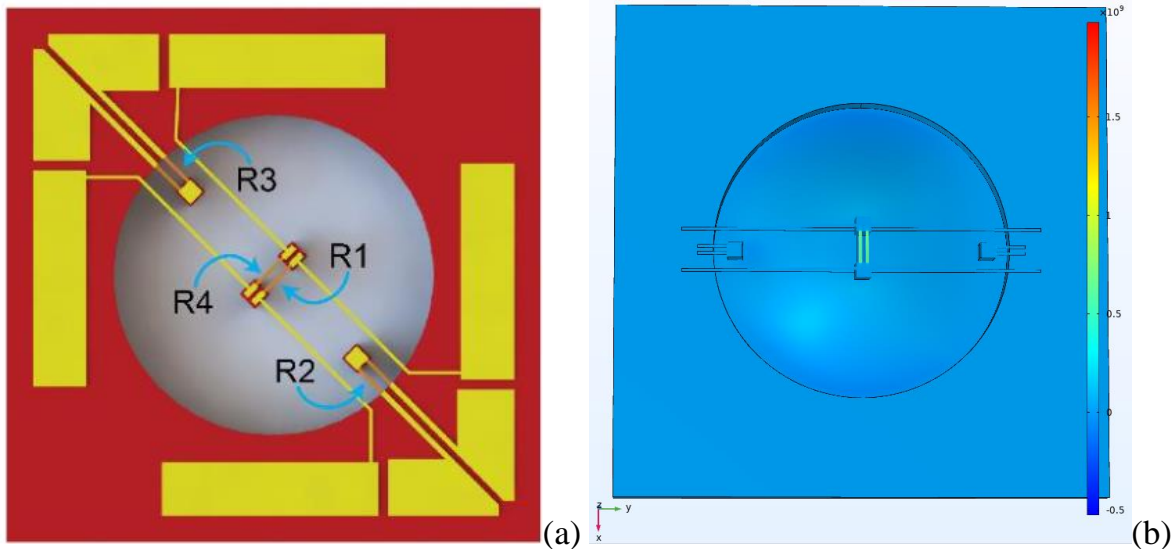

Figure 1. (a) A proposed structure [1],(b) Simulated results of stress amplification of 3C-SiC/Si MEMS pressure sensor.

\*Keywords (5): MEMS pressure sensor, stress, pillar, 3C-SiC micro-beam, piezoresistive

\*References:

[1] Braiden Tong, Tuan-Hung Nguyen, Hong-Quan Nguyen, Tuan-Khoa Nguyen, Thanh Nguyen, Toan Dinh, Ngo Vo Ke Thanh, Truong Huu Ly, Nguyen Chi Cuong, Hoang Ba Cuong, Trinh Xuan Thang, Van Thanh Dau, Dzung Viet Dao, Highly sensitive and robust 3C-SiC/Si pressure sensor with stress amplification structure, *Materials & Design* 224 (2022) 111297.

### 3. Your fullpaper to publish in the Journal

In case of publication in Journal, please send your manuscript (full paper) to 3<sup>rd</sup> IWEMA2022 (email address:3iwema2022@gmail.com) before December 25, 2022.

Please select one of the below Journals for the process review for your publication as (put X) :

**Applied Science** (an Open Access Journal from MDPI, Journal Rank: Q2-Engineering, Multidisciplinary);

**IEEJ** (Transactions on Sensors and Micromachines/Transactions on Electronics, Information and Systems: Q3/Q4);

. Journal of **IKEEE** (Korea, non-Scopus);

. **VNUHCM Press** (Vietnam National University- Ho Chi Minh city; non-Scopus);

Please submit your registration and abstract (around 200 words) to [3iwema2022@gmail.com](mailto:3iwema2022@gmail.com) before **November 10<sup>th</sup>, 2022**.

Full paper for review process and Publications: 5-10 pages (as sample) before **December 15, 2022**.

The 3<sup>rd</sup> International Workshop on Engineering Physics, IC-MEMS-Sensors and  
Their Applications (3<sup>rd</sup>IWEMA2022)  
November-25&26,2022; Ho Chi Minh City, Vietnam

*Host by Faculty of Physics- Engineering Physic, University of Science ,  
Vietnam National University- HCMC)  
and Ono Lab, Tohoku University, Sendai, Japan*

**ORAL SESSION (Session 5, Code: OR-10)**

**1.About speaker**

Title of talk: **Developing a remote online real-time system for radiation monitoring in a radiation therapy accelerator room.**

Author (s): Vo Hong Hai

Institution (s): University of Science-VNUHCM

Country: Vietnam

Speaker: Vo Hong Hai

Academic title: Ph.D,

E-mail: vhai@hcmus.edu.vn Handphone: +84-903-830-100

**2. Abstract**

A medical linear accelerator (LINAC) customizes high energy x-rays or electrons to treat cancers and tumors in radiation therapy room [1]. Beam irradiation of the accelerator for “beam on” and “beam off” is controlled in the operator room nearby. For radiation safety, radiation alarm and/or radiation detectors can be used to warn radiation in the room and nearby. In some cases, it is important to monitor radiation remotely. In this work, we develop a remote online real-time system for “beam on” radiation monitoring in a medical accelerator room of radiation therapy. A real-time radiation detector is installed in the accelerator room recording radiation dose-rate value and transferring data through LAN/WAN to internet. Here, the real-time radiation detector is built with a radiation sensor and embedded electronic

hardware. Dose rate, count rate (count-per-second) are recorded versus real-time. A webservice and a mobile application are built to receive and display data from the radiation detector. Fig.1 shows the system which has 04 components such as a real-time radiation detector, cloud server, user (web/App) and a cloud database. We deployed the system in the radiation therapy room at the Cancer hospital- Ho Chi Minh to monitoring beam on/off via website and mobile App. The response of the system is operated with good performance and fast response. This work is one of our development in the project of ReWES [2].

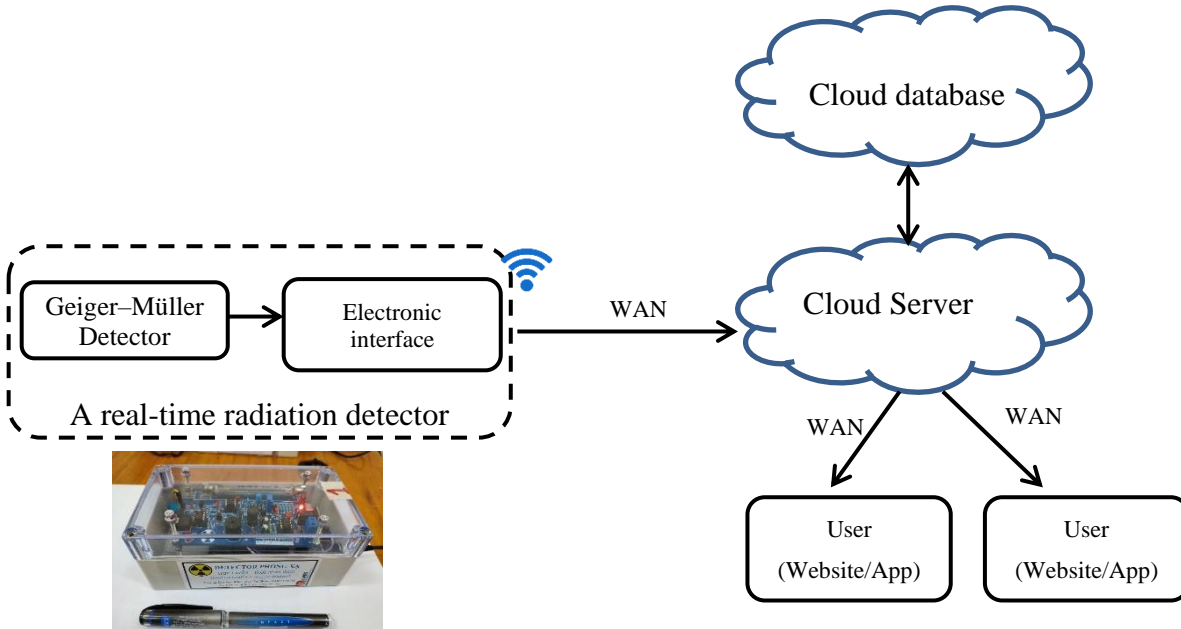

Fig.1. a remote online real-time system for radiation monitoring.

\*Keywords: Real-time radiation monitoring, medical accelerator, embedded system, radiation safety.

\*References:

[1] <http://www.accelerators-for-society.org/>

[2] <https://sites.google.com/hcmus.edu.vn/rewes/>

The 3<sup>rd</sup> International Workshop on Engineering Physics, IC-MEMS-Sensors and  
Their Applications (3<sup>rd</sup>IWEMA2022)  
*November-25&26,2022; Ho Chi Minh City, Vietnam*

*Host by Faculty of Physics- Engineering Physic, University of Science ,  
Vietnam National University- HCMC)  
and Ono Lab, Tohoku University, Sendai, Japan*

**ORAL SESSION (Session 5, Code: OR-11)**

**1.About speaker**

Title of talk: Survey on spiking neural network for feature extraction step to classify electroencephalogram signals.

Author (s): Huynh Viet Quoc and Huynh Van Tuan

Institution (s): Faculty of Physics and Engineering Physics, University of Science,  
Ho Chi Minh City, Vietnam

Country: Viet Nam

Speaker: Huynh Quoc Viet

Academic title: Master of Science, Junior Lecturer

E-mail: [hyqviet@hcmus.edu.vn](mailto:hyqviet@hcmus.edu.vn) Handphone: 0349043204

**2. Abstract**

This paper presents a spiking neural network algorithm aiming at designing a feature extractor that leads to highly separable classes in the feature space. It is based on a hybrid network composed of spiking and artificial neurons. The spiking neuron layer with mutual inhibition was assigned as a feature extractor. In this article, the classification accuracy was demonstrated that the proposed model could reach reasonable values comparable with existing electroencephalogram (EEG) interface systems. The spiking neuron network created the spiking images from 1 to 100 steps at the features of the EEG signal. After that, the images were resized to enhance their quality. For the recognition task, three improvement models of the branch convolution neural network were applied including the

Step convolution neural network (S\_CNN), the Layer additive convolutional neural network (L\_A\_CNN), and the Input additive convolutional neural network (I\_A\_CNN). The experiment results proved the high ability of the spiking neural network in the features extraction step, and the proposed convolution networks were investigated to find suitable performances for the image classification task.

\*Keywords: Electroencephalogram, Spiking neural network, convolution neural network.

\*References:

- [1] S. Aslani et al., "Multi-branch convolutional neural network for multiple sclerosis lesion segmentation," vol. 196, pp. 1-15, 2019.
- [2] L. Chen, S. Li, Q. Bai, J. Yang, S. Jiang, and Y. J. R. S. Miao, "Review of image classification algorithms based on convolutional neural networks," vol. 13, no. 22, p. 4712, 2021.
- [3] G. K. Georgakilas, A. Grioni, K. G. Liakos, E. Chalupova, F. C. Plessas, and P. J. S. r. Alexiou, "Multi-branch convolutional neural network for identification of small non-coding RNA genomic loci," vol. 10, no. 1, pp. 1-10, 2020.
- [4] S. Lobov, V. Mironov, I. Kastalskiy, and V. J. S. Kazantsev, "A spiking neural network in sEMG feature extraction," vol. 15, no. 11, pp. 27894-27904, 2015.
- [5] L. Zuo, L. Zhang, Z.-H. Zhang, X.-L. Luo, and Y. J. J. o. M. S. Liu, "A spiking neural network-based approach to bearing fault diagnosis," vol. 61, pp. 714-724, 2021.

# 4.

# POSTER SESSION

Venue: University of Science, VNUHCM  
*227 Nguyen Van Cu Str., District 5, Ho Chi Minh city,  
Vietnam*

The 3<sup>rd</sup> International Workshop on Engineering Physics, IC-MEMS-Sensors and  
Their Applications (3<sup>rd</sup>IWEMA2022)  
November-25&26,2022; Ho Chi Minh City, Vietnam

Host by Faculty of Physics- Engineering Physic, University of Science ,  
Vietnam National University- HCMC)  
and Ono Lab, Tohoku University, Sendai, Japan

**POSTER (Code: PO-01)**

**1. About speaker**

Title of poster: **Development of a Digital Microfluidics system for point-of-care molecular diagnostics.**

Author(s): Ngo Yen Khanh, Tuan Hoang, Thien Hoang, Nguyen Van Hieu and Huynh Chan Khon.

Institution (s): International University, Vietnam National University, Ho Chi Minh city

Country: Vietnam

Reporter: Ngo Yen Khanh

Academic title: Master student

E-mail: ngoyenkhanh29597@gmasil.com

Handphone: 0935 942 671

**2. Abstract**

Digital Microfluidic (DMF) has been showed spectacular potential in the field of point-of-care (POC) diagnosis due to many advantages such as low cost, rapidity, accuracy, flexibility and capability of operating multiple and parallel biochemical process. In this study, we developed a portable DMF device based on electrowetting-on-dielectric (EWOD) platform combining with a colorimetric Recombinase polymerase amplification (RPA) reaction using SYBR Green I as the detector for results observation, thus diagnosing the present of Malaria disease. By utilizing primers specific for the 3D7 gene, *P. falciparum* plasmids were successfully observed at 37°C in 20 minutes, which is the optimal condition of RPA, positive sample was able to be seen in green color while the negative one was orange. Additionally, an investigation of droplet mobility was conducted in order to enhance the performance of the RPA on DMF system by adding Tween-20, the efficiency in supporting movement of droplets is saturated at concentration 0.4%. This system was relatively accessible and low cost that provided quick and compactor tool for point-of-care diagnostics therefore be suitable to be applied in developing countries, especially places those are lack of medical condition in infection disease prevention.

\*Keywords: Digital Microfluidics, Microfluidic, Point-of-care, Recombinase polymerase amplification.

\*References:

1. Cowman, A. F., J. Healer, D. Marapana and K. Marsh (2016) Malaria: Biology and Disease. *Cell*. 167: 610-624.
2. van Dijk, M. R., A. P. Waters and C. J. Janse (1995) Stable transfection of malaria parasite blood stages. *Science*. 268: 1358-62.
3. World Health, O. (2021) *World malaria report 2021.*, pp. xvi. World Health Organization, Geneva.
4. Trampuz, A., M. Jereb, I. Muzlovic and R. M. Prabhu (2003) Clinical review: Severe malaria. *Crit Care*. 7: 315-23.
5. Landier, J., D. M. Parker, A. M. Thu, V. I. Carrara, K. M. Lwin, C. A. Bonnington, S. Pukrittayakamee, G. Delmas and F. H. Nosten (2016) The role of early detection and treatment in malaria elimination. *Malar J*. 15: 363.
6. Berzosa, P., A. de Lucio, M. Romay-Barja, Z. Herrador, V. González, L. García, A. Fernández-Martínez, M. Santana-Morales, P. Ncogo, B. Valladares, M. Riloha and A. Benito (2018) Comparison of three diagnostic methods (microscopy, RDT, and PCR) for the detection of malaria parasites in representative samples from Equatorial Guinea. *Malar J*. 17: 333.
7. Ochola, L. B., P. Vounatsou, T. Smith, M. L. Mabaso and C. R. Newton (2006) The reliability of diagnostic techniques in the diagnosis and management of malaria in the absence of a gold standard. *Lancet Infect Dis*. 6: 582-8.
8. Ohrt, C., Purnomo, M. A. Sutamihardja, D. Tang and K. C. Kain (2002) Impact of microscopy error on estimates of protective efficacy in malaria-prevention trials. *J Infect Dis*. 186: 540-6.
9. Maltha, J., P. Gillet and J. Jacobs (2013) Malaria rapid diagnostic tests in endemic settings. *Clin Microbiol Infect*. 19: 399-407.
10. Rubio, J. M., R. J. Post, W. M. van Leeuwen, M. C. Henry, G. Lindergard and M. Hommel (2002) Alternative polymerase chain reaction method to identify Plasmodium species in human blood samples: the semi-nested multiplex malaria PCR (SnM-PCR). *Trans R Soc Trop Med Hyg*. 96 Suppl 1: S199-204.
11. Morassin, B., R. Fabre, A. Berry and J. F. Magnaval (2002) One year's experience with the polymerase chain reaction as a routine method for the diagnosis of imported malaria. *Am J Trop Med Hyg*. 66: 503-8.
12. Oriero, E. C., J. Jacobs, J. P. Van Geertruyden, D. Nwakanma and U. D'Alessandro (2015) Molecular-based isothermal tests for field diagnosis of malaria and their potential contribution to malaria elimination. *J Antimicrob Chemother*. 70: 2-13.
13. Piepenburg, O., C. H. Williams, D. L. Stemple and N. A. Armes (2006) DNA detection using recombination proteins. *PLoS Biol*. 4: e204.
14. Zaghoul, H. and M. El-Shahat (2014) Recombinase polymerase amplification as a promising tool in hepatitis C virus diagnosis. *World J Hepatol*. 6: 916-22.
15. Abd El Wahed, A., P. Patel, O. Faye, S. Thaloengsok, D. Heidenreich, P. Matangkasombut, K. Manopwisedjaroen, A. Sakuntabhai, A. A. Sall, F. T. Hufert and M. Weidmann (2015) Recombinase Polymerase Amplification Assay for Rapid Diagnostics of Dengue Infection. *PLoS One*. 10: e0129682.
16. Abd El Wahed, A., S. S. Sanabani, O. Faye, R. Pessôa, J. V. Patriota, R. R. Giorgi, P. Patel, S. Böhlken-Fascher, O. Landt, M. Niedrig, P. M. Zanotto, C. P. Czerny, A. A. Sall and M. Weidmann (2017) Rapid Molecular Detection of Zika Virus in Acute-Phase Urine Samples Using the Recombinase Polymerase Amplification Assay. *PLoS Curr*. 9.
17. Lutz, S., P. Weber, M. Focke, B. Faltin, J. Hoffmann, C. Müller, D. Mark, G. Roth, P. Munday, N. Armes, O. Piepenburg, R. Zengerle and F. von Stetten (2010) Microfluidic lab-on-a-foil for nucleic acid analysis based on isothermal recombinase polymerase amplification (RPA). *Lab Chip*. 10: 887-93.

18. Shen, F., E. K. Davydova, W. Du, J. E. Kreutz, O. Piepenburg and R. F. Ismagilov (2011) Digital isothermal quantification of nucleic acids via simultaneous chemical initiation of recombinase polymerase amplification reactions on SlipChip. *Anal Chem.* 83: 3533-40.
19. Yeh, E. C., C. C. Fu, L. Hu, R. Thakur, J. Feng and L. P. Lee (2017) Self-powered integrated microfluidic point-of-care low-cost enabling (SIMPLE) chip. *Sci Adv.* 3: e1501645.
20. Fair, R. B. (2007) Digital microfluidics: is a true lab-on-a-chip possible? *Microfluidics and Nanofluidics.* 3: 245-281.
21. Cho, S. K., H. Moon and C.-J. Kim (2003) Creating, transporting, cutting, and merging liquid droplets by electrowetting-based actuation for digital microfluidic circuits. *Microelectromechanical Systems, Journal of.* 12: 70-80.
22. Abdelgawad, M. and A. Wheeler (2006) Rapid Prototyping in Copper Substrates for Digital Microfluidics. *Advanced Materials.* 19: 133-137.
23. Zanolli, L. M. and G. Spoto (2013) Isothermal amplification methods for the detection of nucleic acids in microfluidic devices. *Biosensors (Basel).* 3: 18-43.
24. Hoang, T., B.-H. Ly, T.-X. Le, T.-T. Huynh, H.-T. Nguyen, T. V. Vo, T. T. H. Pham and K. Huynh (2020) Minimal microfabrication required digital microfluidic system toward point-of-care nucleic acid amplification test application for developing countries. 26: 1863–1873.

The 3<sup>rd</sup> International Workshop on Engineering Physics, IC-MEMS-Sensors and  
Their Applications (3<sup>rd</sup>IWEMA2022)

*November-25&26,2022; Ho Chi Minh City, Vietnam*

*Host by Faculty of Physics- Engineering Physic, University of Science ,  
Vietnam National University- HCMC)  
and Ono Lab, Tohoku University, Sendai, Japan*

**POSTER (Code: PO-02)**

**1.About speaker**

Title of poster: The study of lithography parameters for the fabricating process of nMOS electrodes

Author (s): Nguyen Hoang Quan\*, Truong Hai Yen, Ho Thanh Huy, Tran Thi Huynh Giao and Nguyen Van Hieu

Institution (s): University of Science, VNUHCM

Country: Viet Nam

Reporter: Nguyen Hoang Quan

Academic title: Master of Science, Junior lecturer

E-mail: nhquan@hcmus.edu.vn

Handphone: 0938551383

**2.Abstract**

With outstanding advantages from the ability to quickly close large current and voltage, high input impedance, high thermal stability, and high working frequency, MOSFETs are widely used in control circuits and digital circuits, especially integrated circuits. Therefore, researching, manufacturing and gradually mastering MOS technology is essential for laboratories to manufacturing plants.

In this work, we designed and fabricated a computer-controlled mini Photolithography Machine with a resolution of less than 50um and tested the fabrication of nMOS electrodes to determine optical parameters. optimal etching through 18 test samples as follows:

irradiation time ( $t_{\text{ex}}$ ) 45s, rising time ( $t_{\text{dev}}$ ) 55s, distance between emission source and mask (h) 10 cm, intensity for UV LED emission (I) 50 mA and irradiation angle ( $\theta$ )  $0^\circ$ .

Samples performed in our photolithography cabinet were verified by SEM technology (Semiconductors lab, SHTP labs). They were checked on a high-definition scale down to  $8\mu\text{m}$  size of nMOS technology. Furthermore, the photolithography cabinet succeeded in manufacturing and conducted effective initial experiments on photolithography and the surveying of some optimal parameters for the study of MEMS, sensors, and electronic devices.

\* Keywords: electrochemical biosensors, zigzag electrode, sensitivity, E.coli, pathogens.

\* References:

- [1]. Yo-Sheng Lin, Guo-Hao Li, & Nguyen Van Hieu. (2015). A 75–85GHz Down-conversion mixer with integrated marchand baluns in 90 nm CMOS with excellent matching and port-to-port isolation for automotive radars. *Microwave and Optical Technology Letters*, 57, 1, 73-80. <https://doi.org/10.1002/mop.28774>
- [2]. Jaeger, Richard C. (2002). *Introduction to Microelectronic Fabrication (2nd ed.)*. New Jersey: Upper Saddle River: Prentice Hall.
- [3]. Truong Hai Yen. (2019). *Improving the Ultraviolet Irradiation System (UIS) for electrode component photolithography researchs, (Bachelor thesis)*. University of Science, VNUHCM.

The 3<sup>rd</sup> International Workshop on Engineering Physics, IC-MEMS-Sensors and  
Their Applications (3<sup>rd</sup>IWEMA2022)

*November-25&26,2022; Ho Chi Minh City, Vietnam*

*Host by University of Science (Vietnam National University- HCMC)  
and Tohoku University (Japan)*

**POSTER (Code: PO-03)**

**1.About speaker**

Title of poster: Application of deep learning in fault detection using thermal image for Photovoltaic panel.

Author (s):Nguyen Phuoc Hoang Khang, Trieu Thien Khang and Nguyen Chi Nhan

Institution (s): University of Science, VNU HCM

Country: Vietnam

Reporter: Nguyen Phuoc Hoang Khang

Academic title: Engineer, Master student, Assistant lecturer

E-mail: [nphkhang@hcmus.edu.vn](mailto:nphkhang@hcmus.edu.vn)

Handphone: 0918035984

**2. Abstract**

The research focus on the implementation of different model machines in fault location determining of solar panels using thermal images. When fault occurred, in solar array would create hotspots which make the internal temperature of the solar panels rising and appear on thermal images. The objective of the study is to survey some machine learning model, such as YOLOv3, Mask R-CNN and RetinaNet, on detecting those hotspots on the infrared image, by that, able to increase the efficiency of repair and maintenance processes. The survey conducted based on the image dataset built by a research group Energies of the Marches University of Technology (Università Politecnica delle Marche), Ancona, Italy. The results show potential application of such models in which the RetinaNet is 98%, the Mask R-CNN is 95% and YOLOv3 is 82%.

\*Keywords: Deep learning, Fault detection, Photovoltaic panel, CNN.

\*References:

The 3<sup>rd</sup> International Workshop on Engineering Physics, IC-MEMS-Sensors and  
Their Applications (3<sup>rd</sup>IWEMA2022)  
November-25&26,2022; Ho Chi Minh City, Vietnam

*Host by Faculty of Physics- Engineering Physic, University of Science ,  
Vietnam National University- HCMC)  
and Ono Lab, Tohoku University, Sendai, Japan*

**POSTER (Code: PO-04)**

**1.About speaker**

Title of poster: **IoT System for Aquaponics garden with vegetables and fishes.**

Author (s): Tran Hoang Nhut, Ho Thanh Huy, Nguyen Chi Nhan and Nguyen Van Hieu

Institution (s): University of Science, VNUHCM

Country: Viet Nam

Reporter: Tran Hoang Nhut

Academic title: Master student, Assistant lecture

E-mail: thnhut@hcmus.edu.vn

Handphone: 0837251098

**2. Abstract**

In the shortage of clean water and food poisoning by spraying chemicals contaminated with chemicals. So the demand for clean food is concerned by everyone, for the people of the city, the land is crowded so having a separate vegetable garden is difficult to implement. So many studies have come up with the Aquaponics model. The model is being widely adopted with the advantage of using LEDs instead of sunlight. In addition, taking care and monitoring the growth of vegetables and fish at home will help to gain a better understanding of recreational and hydroponic techniques through a home-grown vegetable garden. Foreseeing this need, on the basis of successfully designed and manufactured models, the research team proceeds to improve, design and develop a large-scale Aquaponics system at Linh Trung laboratory. We studied, designed and completed the original content. Aquaponics aquariums are shown and operated with the following functions:

- Design of a smart electronic control system for the Aquaponic garden with vegetables and fish at EE&IA Lab displays a live environment parameter: temperature, humidity, and light intensity.
- Displays and stores values read by the application on the smartphone.
- Control electronic devices from smartphone.
- Automatic mode of operation.
- Survey system performance, measure and evaluate information environments.



*Fig.1. The Aquaponic garden for lab model at Linh Trung campus, HCMUS.*

\*Keywords: LED, Hydroponics, Aquaponics, Smart Farm, IoT.

\*References:

[1]. Nguyen Chi Nhan: Lecture for smart home, DPEE- HCMUS (8,2017);

[2]. Phan Thien Luan, Bachelor's Thesis "Design and Development of a Smart Electronic Control System for The Mini Aquaponics Garden in House With Vegetables And Fishes", DPEE- HCMUS (8,2019);

[3]. Le Thi Thao Nhi, bachelor's Thesis "Design and Development of A Smart Electronic Control System for The Mini Aquaponics Garden In Linh Trung laboratory With Vegetables And Fishes" DPEE- HCMUS (8,2019);

The 3<sup>rd</sup> International Workshop on Engineering Physics, IC-MEMS-Sensors and  
Their Applications (3<sup>rd</sup>IWEMA2022)  
November-25&26,2022; Ho Chi Minh City, Vietnam

*Host by Faculty of Physics- Engineering Physic, University of Science ,  
Vietnam National University- HCMC)  
and Ono Lab, Tohoku University, Sendai, Japan*

**POSTER (Code: PO-05)**

**1.About speaker:**

Title of poster: **SERS Sensor based on Ag Nanoparticles for fast detection of fast GREEN FCF.**

Author (s): Nguyen Hoang Long\*, Nguyen Huu Ke and Le Vu Tuan Hung

Institution (s): University of Science, VNUHCM

Country: Viet Nam

Speaker: Nguyen Hoang Long\*

Academic title: Master student, Assistant lecturer

E-mail:nhlong@hcmus.edu.vn

Handphone: 0916301784

**2.Abstract**

work, the stability and repeatability of surface-enhanced Raman scattering (SERS) substrates based on Ag nanoparticles were investigated. Ag nanoparticles were deposited on a glass substrate by DC magnetron sputtering with oblique angle deposition (OAD) technique. The obtained substrate shows excellent SERS amplification due to the surface plasmon resonance effect of Ag nanoparticles with high density of “hot spots”, along with high stability and uniformity. The results of the Raman measurements of the substrate for Fast Green FCF reached the limit of detection (LOD) of 0.01 ppm and the relative standard deviation (RSD) of 8.06%, indicating that the Ag NPs substrate could be a SERS detection platform for organic compounds in food with great development potential.

\*Keywords (4): SERS sensor, Ag nanoparticles, DC magnetron sputtering, Fast Green FCF

\*References:

- [1] X. Jin, Y. Wu, Z. Lin, D. Liang, F. Wang, X. Zheng, H. Liu, W. Lv, G. Liu, Plasmonic Ag nanoparticles decorated copper-phenylacetylide polymer for visible-light-driven photocatalytic reduction of Cr(VI) and degradation of PPCPs: Performance, kinetics, and mechanism, *Journal of Hazardous Materials*. 425 (2022) 127599.
- [2] R. Selvapriya, T. Abhijith, V. Ragavendran, V. Sasirekha, V.S. Reddy, J.M. Pearce, J. Mayandi, Impact of coupled plasmonic effect with multishaped silver nanoparticles on efficiency of dye sensitized solar cells, *Journal of Alloys and Compounds*. 894 (2022), 162339.
- [3] M. Aslani, R. Talebi, D. Vashae, Coupling Light in Ion-Exchanged Waveguides by Silver Nanoparticle-Based Nanogratings: Manipulating the Refractive Index of Waveguides. 5 (2022), 5439–5447.
- [4] G.G. Buyukgoz, A.G. Bozkurt, N.B. Akgul, U. Tamer, I.H. Boyaci, Spectroscopic detection of aspartame in soft drinks by surface-enhanced Raman spectroscopy, *European Food Research and Technology*. 240 (2015), 567 – 575.
- [5] T. Wang, S. Wang, Z. Cheng, J. Wei, L. Yang, Z. Zhong, H. Hu, Y. Wang, B. Zhou, P. Li, Emerging core–shell nanostructures for surface-enhanced Raman scattering (SERS) detection of pesticide residues, *Chemical Engineering Journal*. 424, (2021), 130323.
- [6] T. Fernandes, S. Fateixa, M. Ferro, H. I.S. Nogueira, A. L.D, Silva, T. Trindade, Colloidal dendritic nanostructures of gold and silver for SERS analysis of water pollutants, *Journal of Molecular Liquids*. 337 (2021), 116608.
- [7] X. Gao, Y. Yin, H. Wu, Z. Hao, J. Li, S. Wang, Y. Liu, Integrated SERS Platform for Reliable Detection and Photothermal Elimination of Bacteria in Whole Blood Samples, *Analytical Chemistry*. 93 (2021), 1569–1577.
- [8] E. V. Solovyeva, E. V. Ubyivovk, A. S. Denisova, Effect of diaminostilbene as a molecular linker on Ag nanoparticles: SERS study of aggregation and interparticle hot spots in various environments, *Colloids and Surfaces A: Physicochemical and Engineering Aspects*. 538 (2018), 542 – 548.
- [9] N. R. Barveen, T. J. Wang, Y. H. Chang, Z. Y. Liu, Ultrasensitive and reusable SERS probe for the detection of synthetic dyes in food industry through hybrid flower-shaped ZnO@Ag nanostructures, *Journal of Alloys and Compounds*. 861 (2021), 157952.
- [10] R. Šakalys, K. W. Kho, T. E. Keyes, A reproducible, low cost microfluidic microcavity array SERS platform prepared by soft lithography from a 2 photon 3D printed template, *Sensors and Actuators B: Chemical*. 340 (2021), 129970.
- [11] L. Bachenheimer, R. Scherzer, P. Elliott, S. Stagon, L. Gasparov, H. Huang, Degradation Mechanism of Ag Nanorods for Surface Enhanced Raman Spectroscopy, *Scientific Reports*. 7 (2017), 16282.
- [12] P. Eiamchai, C. Chananonwathorn, M. Horprathum, V. Patthanasettakul, S. Limwichean, N. Nuntawong, Spatial elemental investigations in nanostructured alloyed Ag/Au SERS substrates by

magnetron sputtering oblique-angle co-deposition towards increased performance and shelf life, *Applied Surface Science*. 513 (2020), 145748.

[13] J. Mittal, R. Jain, M. M. Sharma, Phytofabrication of silver nanoparticles using aqueous leaf extract of *Xanthium strumarium* L. and their bactericidal efficacy, *Advances in Natural Sciences: Nanoscience and Nanotechnology*. 8 (2017), 025011.

[14] G. Hu, G. Liang, W. Zhang, W. Jin, Y. Zhang, Q. Chen, Y. Cai, W. Zhang, Silver nanoparticles with low cytotoxicity: controlled synthesis and surface modification with histidine, *Journal of Materials Science*. 53 (2018), 4768–4780.

[15] C. R. Rekha, V.U. Nayar, K.G. Gopchandran, Synthesis of highly stable silver nanorods and their application as SERS substrates, *Journal of Science: Advanced Materials and Devices*. 3 (2018), 196 – 205.

[16] J. C. Gukowsky, T. Xie, S. Gao, Y. Qu, L. He, Rapid identification of artificial and natural food colorants with surface enhanced Raman spectroscopy, *Food Control*. 92 (2018), 267 – 275.

The 3<sup>rd</sup> International Workshop on Engineering Physics, IC-MEMS-Sensors, and  
Their Applications (3<sup>rd</sup>IWEMA2022)  
November-25&26,2022; Ho Chi Minh City, Vietnam

*Host by Faculty of Physics- Engineering Physic, University of Science ,  
Vietnam National University- HCMC)  
and Ono Lab, Tohoku University, Sendai, Japan*

**POSTER (Code: PO-06)**

**1.About speaker**

Title of poster: **Design and implementation fo Doppler radar system target classification using deep learning.**

Author (s): Ha Minh Khue\*, Nguyen Duc Hoang Ha, Nguyen Hoang Quan and Nguyen Chi Nhan.

Institution (s): University of Science, VNUHCM

Country: Viet Nam

Speaker: Ha Minh Khue

Academic title: Master student, assistant lecturer

E-mail: hmkhue@hcmus.edu.vn

Handphone: 0366458101

**2.Abstract**

In this study, we proposed a target human motion classification system that can operate in indoor scenarios. In scenarios with non-target micro-motion interference, the proposed system was evaluated with 4 different situations: non-human being, human walking with arm swinging, human walking without arm swinging, and human running. AI radar approach emerges [1,2] with many advantages compared to other technologies, such as low cost, ensuring privacy, accuracy, not being affected by the environment, etc. However, the source of training dataset of radar is still limited because it has not been developed, creating barriers to the application of radar AI technology in our life [3]. The radar dataset and classifying human motion characteristics as a basis for comparison and evaluation for future studies. To achieve the above goals, we conducted a prototype board kit of the signal acquisition circuitry for the band K (24 GHz frequency) [4] continuous wave radar sensor. The Radar acquisition system consists of 3 main parts: Doppler Radar sensor, baseband

amplifier and ADC system built on DE10-Nano SoC board. Then, we implement some advance digital signal processing methods to get time-frequency representation of signal like Short-time Fourier transform and Mel-spectrogram to obtain micro-Doppler spectrogram of each motion and perform training as well as predicting on extracted motion features. The results reveal that the capability of human classification by proposed Doppler Radar system is quite feasible after comparing with another studies [5, 6, 7]. To actualize the application of AI Radar in everyday life, proposed system must be improved in more scenarios, as well as the accuracy and speed of classification system.

\*Keywords: AI radar, Doppler radar, human detection, motion-based object detection.

\*References:

1. E. L. Chuma and Y. Iano, "A Movement Detection System Using Continuous-Wave Doppler Radar Sensor and Convolutional Neural Network to Detect Cough and Other Gestures", *IEEE Sensors Journal*, vol. 21, pp. 2921-2928, 2021.
2. X. Ma, R. Zhao, X. Liu, and H. Kuang, Classification of Human Motions Using Micro-Doppler Radar in the Environments with Micro-Motion Interference, *Sensors*, vol. 19, 2019.
3. S. Z. Gurbuz and M. G. Amin, Radar-Based Human-Motion Recognition with Deep Learning, *IEEE Signal Processing Magazine*, pp. 16-28, 2019.
4. H.M. Khue, N.H. Quan, N.D.H. Ha, Research work: Doppler Radar system for motion detection (2021-2022), *Research Project*, VNUHCM-University of Science.
5. J. Kwon and N. Kwak, "Human detection by neural networks using a low-cost short-range Doppler radar sensor," in *2017 IEEE Radar Conference (RadarConf)*, 2017, pp. 0755–0760.
6. I. Bilik and J. Tabrikian, "Radar target classification using doppler signatures of human locomotion models," *IEEE Transactions on Aerospace and Electronic Systems*, vol. 43, no. 4, pp. 1510–1522, 2007.
7. Ma X, Zhao R, Liu X, Kuang H, Al-qaness MAA. Classification of Human Motions Using Micro-Doppler Radar in the Environments with Micro-Motion Interference. *Sensors*. 2019; 19(11):2598. <https://doi.org/10.3390/s19112598>

The 3<sup>rd</sup> International Workshop on Engineering Physics, IC-MEMS-Sensors and  
Their Applications (3<sup>rd</sup>IWEMA2022)  
*November-25&26,2022; Ho Chi Minh City, Vietnam*

*Host by Faculty of Physics- Engineering Physic, University of Science ,  
Vietnam National University- HCMC)  
and Ono Lab, Tohoku University, Sendai, Japan*

**POSTER (Code: PO-07)**

Title of poster: **The equipment for testing food 's quality using the image by machine learning.**

Author (s): Tran Thien Minh, Nguyen Hoang Quan, Le Hong Nhung and Nguyen Van Hieu

Institution (s): University of Science, VNUHCM

Country: Viet Nam

Reporter: Nguyen Hoang Quan\* and Tran Thien Minh

Academic title: \*MSc, Junior lecturer

E-mai: nhquan@hcmus.edu.vn and 18130086@student.hcmus.edu.vn

Handphone:

**Abstract**

Meat quality and safety is currently a top concern for the food industry worldwide, as it relates to economic development and public health. To meet the growing consumer demand for high-quality meat, the meat industry must monitor the freshness and quality of the product as expected by consumers. The main purpose of the thesis “Designing a trial system for assessing food quality through photos using machine learning” is to test the quality of raw meat by means of images to contribute to proposing a convenient monitoring and inspection of meat quality to warn and ensure safety for consumers.

This topic focuses on the design of a system to create an environment for collecting and monitoring food (meat) and building a machine learning model to determine the fresh or spoiled meat status of three test types of meat: pork, beef, and chicken using deep learning technique, convolutional neural networking (CNN). The topic uses a dataset of 7752 images for training purposes with 1000-1200 images for each class. The model has been implemented in python with the Keras and Tensorflow deep learning library packages. The model accuracy achieved was 98.7% for determining the meat condition of the three tested meats. In order to be easily accessible to users, the topic has deployed the model to the website through a Python web framework called Flask.

\*Keywords: Convolutional neural networking, Machine Learning, Rasberry Pi, image processing, meat.

\*References:

[1]. Xiaohui Weng, Xiangyu Luan, Cheng Kong, Zhiyong Chang, Yinwu Li, Shujun Zhang, Salah Al-Majeed, Yingkui Xiao, "A Comprehensive Method for Assessing Meat Freshness Using Fusing Electronic Nose, Computer Vision, and Artificial Tactile Technologies," *Journal of Sensors*, 2020.

[2]. Oguzhan Ulucan, Diclehan Karakaya Ulucan, Mehmet Turkan, "Meat Quality Assessment based on Deep Learning," in *Innovations in Intelligent Systems and Applications Conference (ASYU)*, 2019.

[3]. Charlie, "insights.magestore.com," 11 May 2020. [Online]. Available: <https://insights.magestore.com/posts/tong-quan-ai-artificial-intelligence>. [Accessed 15 2022].

[4]. Khanh Pham Dinh, "Convolutional Neural Network," [Online]. Available: <https://www.kaggle.com/code/phamdinhkhanh/convolutional-neural-network-p1/notebook>.

[5] O. Uluca, "Meat Quality Assessment Dataset," [Online]. Available: <https://www.kaggle.com/datasets/crowww/meat-quality-assessment-based-on-deep-learning/code>.

[6]. Erna Husna Kana, Rovina Kobun, Sylvester Mantihal, "Current Detection Techniques for Monitoring the Freshness of Meat-Based Products: A Review," *Journal of Packaging Technology and Research*, September 2021.

[7]. J. L. W. En, "Building a Web Application to Deploy Machine Learning Models," 2020. [Online]. Available: <https://towardsdatascience.com/building-a-web-application-to-deploy-machine-learning-models-e224269c1331>.

[8]. "Raspberry Pi Documentation," [Online].

Available: <https://www.raspberrypi.com/documentation/computers/os.html>

The 3<sup>rd</sup> International Workshop on Engineering Physics, IC-MEMS-Sensors and  
Their Applications (3<sup>rd</sup>IWEMA2022)  
November-25&26,2022; Ho Chi Minh City, Vietnam

*Host by Faculty of Physics- Engineering Physic, University of Science ,  
Vietnam National University- HCMC)  
and Ono Lab, Tohoku University, Sendai, Japan*

**POSTER (Code: PO-08)**

**1.About speaker**

Title of talk: Checking diseases through cantaloupe leaves using Convolutional Neural Network (CNN) Algorithm

Author (s): Le Hong Nhung, Tran Thien Minh, Ho Thanh Huy, Tran Quoc Phong and Nguyen Van Hieu

Institution (s): University of Science, VNUHCM

Country: Viet Nam

Speaker: Nguyen Hoang Quan\* and Le Hong Nhung

Academic title: \*Master of Science, Junior lecturer

E-mai: nhquan@hcmus.edu.vn and 18130105@student.hcmus.edu.vn

Handphone:

**2.Abstract**

This report presents this research focusing on plant growth monitoring by IoT system, using AI to recognize and classify diseases on cantaloupe leaves, applying Convolutional Neural Network (CNN) algorithm.

Some knowledge about some common diseases on cantaloupe plants were studied: powdery mildew (caused by the fungus *Pseudoperonospora cubensis*), green leaf wilt (change in weather, heat shock). The method is to perform many times to split the dataset, enhance the data and generalize the CNN model (using a dataset of nearly 8000 images in the ratio 3:1 with 3 training and 1 testing, the Epoch number is 45 iterations, Adam optimization function). Use python language and achieve 98% accuracy when identifying leaf diseases on cantaloupe. After testing the model at the RCHAA melon garden, some comments were made as follows: The hardware's perfection is quite good (getting environmental parameters and melon images), building the model. disease prediction, the initial prediction on the web is not yet highly accurate.

For future application and combination with other models, some recommendations are as follows: Build a more diverse dataset, use better components, test many other optimization algorithms, combination of both identification and treatment (automatic spraying).



*Fig.1. IoT system model for growth observation of melon at RCHAA University of Science (VNUHCM).*

\*Keywords: Convolutional neural networking (CNN), Machine Learning, melon, powdery mildew, green leaf wilt.

\*References:

- [1]. N. M. T. Đặng Hoàng Anh Tuấn, "Tạp chí Khoa Học và Công Nghệ Việt Nam," 16 9 2021. [Online]. Available: 1135-Văn bản của bài báo-4112-1-10-20211124. [Accessed 5 2022].
- [2]. Azath, "Hindawi," 16 Jun 2021. [Online]. Available: <https://www.hindawi.com/journals/jece/2021/9981437/>. [Accessed June 2022].
- [3]. "Quy trình kỹ thuật trồng dưa lưới" [Online]. Available: <https://vietaseeds.com/quy-trinh-ky-thuat-trong-dua-luoi.html>. [Accessed 04 2022].
- [4]. Kaggle, "Plant Disease Detection using Keras," [Online]. Available: <https://www.kaggle.com/code/emmarex/plant-disease-detection-using-keras/notebook>. [Accessed April 2022].
- [5]. D. Yoo, 15 April 2021. [Online]. Available: <https://towardsdatascience.com/creating-a-simple-image-classification-machine-learning-demo-with-gradioml-361a245d7b50>. [Accessed June 2022].
- [6]. M. Z. e. Abidine, July 2022. [Online]. Available: [https://www.researchgate.net/publication/342774605\\_Machine\\_Learning-Based\\_Classification\\_of\\_Powdery\\_Mildew\\_Severity\\_on\\_Melon\\_Leaves](https://www.researchgate.net/publication/342774605_Machine_Learning-Based_Classification_of_Powdery_Mildew_Severity_on_Melon_Leaves). [Accessed June 2022].

The 3<sup>rd</sup> International Workshop on Engineering Physics, IC-MEMS-Sensors and  
Their Applications (3<sup>rd</sup>IWEMA2022)  
November-25&26,2022; Ho Chi Minh City, Vietnam

*Host by Faculty of Physics- Engineering Physic, University of Science ,  
Vietnam National University- HCMC)  
and Ono Lab, Tohoku University, Sendai, Japan*

**POSTER (Code: PO-08)**

**1.About speaker**

Title of talk: Checking diseases through cantaloupe leaves using Convolutional Neural Network (CNN) Algorithm

Author (s): Le Hong Nhung, Tran Thien Minh, Ho Thanh Huy, Tran Quoc Phong and Nguyen Van Hieu

Institution (s): University of Science, VNUHCM

Country: Viet Nam

Speaker: Nguyen Hoang Quan\* and Le Hong Nhung

Academic title: \*Master of Science, Junior lecturer

E-mai: nhquan@hcmus.edu.vn and 18130105@student.hcmus.edu.vn

Handphone:

**2.Abstract**

This report presents this research focusing on plant growth monitoring by IoT system, using AI to recognize and classify diseases on cantaloupe leaves, applying Convolutional Neural Network (CNN) algorithm.

Some knowledge about some common diseases on cantaloupe plants were studied: powdery mildew (caused by the fungus *Pseudoperonospora cubensis*), green leaf wilt (change in weather, heat shock). The method is to perform many times to split the dataset, enhance the data and generalize the CNN model (using a dataset of nearly 8000 images in the ratio 3:1 with 3 training and 1 testing, the Epoch number is 45 iterations, Adam optimization function). Use python language and achieve 98% accuracy when identifying leaf diseases on cantaloupe. After testing the model at the RCHAA melon garden, some comments were made as follows: The hardware's perfection is quite good (getting environmental parameters and melon images), building the model. disease prediction, the initial prediction on the web is not yet highly accurate.

For future application and combination with other models, some recommendations are as follows: Build a more diverse dataset, use better components, test many other optimization algorithms, combination of both identification and treatment (automatic spraying).



*Fig.1. IoT system model for growth observation of melon at RCHAA University of Science (VNUHCM).*

\*Keywords: Convolutional neural networking (CNN), Machine Learning, melon, powdery mildew, green leaf wilt.

\*References:

- [1]. N. M. T. Đặng Hoàng Anh Tuấn, "Tạp chí Khoa Học và Công Nghệ Việt Nam," 16 9 2021. [Online]. Available: 1135-Văn bản của bài báo-4112-1-10-20211124. [Accessed 5 2022].
- [2]. Azath, "Hindawi," 16 Jun 2021. [Online]. Available: <https://www.hindawi.com/journals/jece/2021/9981437/>. [Accessed June 2022].
- [3]. "Quy trình kỹ thuật trồng dưa lưới" [Online]. Available: <https://vietaseeds.com/quy-trinh-ky-thuat-trong-dua-luoi.html>. [Accessed 04 2022].
- [4]. Kaggle, "Plant Disease Detection using Keras," [Online]. Available: <https://www.kaggle.com/code/emmarex/plant-disease-detection-using-keras/notebook>. [Accessed April 2022].
- [5]. D. Yoo, 15 April 2021. [Online]. Available: <https://towardsdatascience.com/creating-a-simple-image-classification-machine-learning-demo-with-gradioml-361a245d7b50>. [Accessed June 2022].
- [6]. M. Z. e. Abidine, July 2022. [Online]. Available: [https://www.researchgate.net/publication/342774605\\_Machine\\_Learning-Based\\_Classification\\_of\\_Powdery\\_Mildew\\_Severity\\_on\\_Melon\\_Leaves](https://www.researchgate.net/publication/342774605_Machine_Learning-Based_Classification_of_Powdery_Mildew_Severity_on_Melon_Leaves). [Accessed June 2022].